



# Doctrine and Covenants and Church History

Study Guide for Home-Study Seminary Students

# Doctrine and Covenants and Church History

Study Guide for Home-Study Seminary Students

Published by  
The Church of Jesus Christ of Latter-day Saints  
Salt Lake City, Utah

Comments and corrections are appreciated. Please send them to:

Seminaries and Institutes of Religion Curriculum Services

50 East North Temple Street

Salt Lake City, UT 84150-0008 USA

Email: [ces-manuals@ldschurch.org](mailto:ces-manuals@ldschurch.org)

Please list your complete name, address, ward, and stake.  
Be sure to give the title of the manual. Then offer your comments.

© 2013 by Intellectual Reserve, Inc.

All rights reserved

Printed in the United States of America

English approval: 8/12

# Contents

Introduction to the Home-Study Seminary Program . . . . .	v
Doctrine and Covenants and Church History Reading Chart . . .	viii
Welcome to the Doctrine and Covenants and Church History . . . .	ix
Doctrine and Covenants and Church History Chronology . . . . .	xi
Introduction to Scripture Mastery . . . . .	xii
100 Scripture Mastery Passages . . . . .	xiii
Introduction to Basic Doctrines . . . . .	xiv
Basic Doctrines . . . . .	xv
Unit 1	
Day 1 The Plan of Salvation . . . . .	1
Day 2 The Great Apostasy . . . . .	3
Day 3 Doctrine and Covenants 1 . . . . .	6
Day 4 Studying the Scriptures . . . . .	9
Unit 2	
Day 1 Joseph Smith—History 1:1–20 . . . . .	12
Day 2 Joseph Smith—History 1:21–26 . . . . .	15
Day 3 Joseph Smith—History 1:27–54; Doctrine and Covenants 2 . . . . .	17
Day 4 Joseph Smith—History 1:55–65 . . . . .	20
Unit 3	
Day 1 Doctrine and Covenants 3; 10 . . . . .	23
Day 2 Doctrine and Covenants 4 . . . . .	26
Day 3 Doctrine and Covenants 5 . . . . .	28
Day 4 Joseph Smith—History 1:66–67; Doctrine and Covenants 6–7 . . . . .	31
Unit 4	
Day 1 Doctrine and Covenants 8–9 . . . . .	33
Day 2 Doctrine and Covenants 11–12 . . . . .	36
Day 3 Joseph Smith—History 1:68–75; Doctrine and Covenants 13 . . . . .	38
Day 4 Doctrine and Covenants 14–16 . . . . .	41
Unit 5	
Day 1 Doctrine and Covenants 17 . . . . .	44
Day 2 Doctrine and Covenants 18 . . . . .	47
Day 3 Doctrine and Covenants 19:1–22 . . . . .	52
Day 4 Doctrine and Covenants 19:23–41 . . . . .	54
Unit 6	
Day 1 Doctrine and Covenants 20:1–36 . . . . .	56
Day 2 Doctrine and Covenants 20:38–67 . . . . .	59
Day 3 Doctrine and Covenants 20:37, 68–84 . . . . .	61
Day 4 Doctrine and Covenants 21–23 . . . . .	64
Unit 7	
Day 1 Doctrine and Covenants 24–26 . . . . .	67
Day 2 Doctrine and Covenants 27 . . . . .	71
Day 3 Doctrine and Covenants 28 . . . . .	73
Day 4 Doctrine and Covenants 29:1–30 . . . . .	76
Unit 8	
Day 1 Doctrine and Covenants 29:31–50 . . . . .	78
Day 2 Doctrine and Covenants 30–32 . . . . .	81
Day 3 Doctrine and Covenants 33–34 . . . . .	84
Day 4 Doctrine and Covenants 35 . . . . .	87
Unit 9	
Day 1 Doctrine and Covenants 36–37 . . . . .	90
Day 2 Doctrine and Covenants 38 . . . . .	92
Day 3 Doctrine and Covenants 39–40 . . . . .	95
Day 4 At the Ohio . . . . .	97
Unit 10	
Day 1 Doctrine and Covenants 41 . . . . .	100
Day 2 Doctrine and Covenants 42:1–29 . . . . .	102
Day 3 Doctrine and Covenants 42:30–93 . . . . .	105
Day 4 Doctrine and Covenants 43–44 . . . . .	108
Unit 11	
Day 1 Doctrine and Covenants 45:1–15 . . . . .	110
Day 2 Doctrine and Covenants 45:16–75 . . . . .	112
Day 3 Doctrine and Covenants 46 . . . . .	116
Day 4 Doctrine and Covenants 47–48 . . . . .	119
Unit 12	
Day 1 Doctrine and Covenants 49 . . . . .	121
Day 2 Doctrine and Covenants 50 . . . . .	124
Day 3 Doctrine and Covenants 51–52 . . . . .	127
Day 4 Doctrine and Covenants 53–56 . . . . .	129
Unit 13	
Day 1 The Center Place of Zion . . . . .	133
Day 2 Doctrine and Covenants 57 . . . . .	136
Day 3 Doctrine and Covenants 58 . . . . .	139
Day 4 Doctrine and Covenants 59 . . . . .	141
Unit 14	
Day 1 Doctrine and Covenants 60–62 . . . . .	144
Day 2 Doctrine and Covenants 63 . . . . .	147
Day 3 Doctrine and Covenants 64:1–19 . . . . .	149
Day 4 Doctrine and Covenants 64:20–43 . . . . .	151
Unit 15	
Day 1 Doctrine and Covenants 65–66 . . . . .	154
Day 2 Doctrine and Covenants 67 . . . . .	156
Day 3 Doctrine and Covenants 68 . . . . .	159
Day 4 Doctrine and Covenants 69–71 . . . . .	161
Unit 16	
Day 1 Doctrine and Covenants 72–74 . . . . .	164
Day 2 Doctrine and Covenants 75 . . . . .	167
Day 3 Doctrine and Covenants 76:1–49 . . . . .	170
Day 4 Doctrine and Covenants 76:50–80 . . . . .	173

Unit 17		Unit 26	
Day 1	Doctrine and Covenants 76:81–119; 77 . . . . .	Day 1	Doctrine and Covenants 121:1–10; 122 . . . . .
Day 2	Doctrine and Covenants 78–80 . . . . .	Day 2	Doctrine and Covenants 121:11–33 . . . . .
Day 3	Doctrine and Covenants 81 . . . . .	Day 3	Doctrine and Covenants 121:34–46 . . . . .
Day 4	Doctrine and Covenants 82–83 . . . . .	Day 4	Doctrine and Covenants 123; The Establishment of Nauvoo . . . . .
Unit 18			295
Day 1	Doctrine and Covenants 84:1–42 . . . . .	Unit 27	
Day 2	Doctrine and Covenants 84:43–120 . . . . .	Day 1	Doctrine and Covenants 124:1–83 . . . . .
Day 3	Doctrine and Covenants 85–86 . . . . .	Day 2	Doctrine and Covenants 124:84–145; 125–26 . . . . .
Day 4	Doctrine and Covenants 87 . . . . .	Day 3	Doctrine and Covenants 127; 128:1–11 . . . . .
		Day 4	Doctrine and Covenants 128:12–25 . . . . .
Unit 19			308
Day 1	Doctrine and Covenants 88:1–40 . . . . .	Unit 28	
Day 2	Doctrine and Covenants 88:41–69 . . . . .	Day 1	Doctrine and Covenants 129; 130:1–11, 22–23 . . . . .
Day 3	Doctrine and Covenants 88:70–141 . . . . .	Day 2	Doctrine and Covenants 130:12–21 . . . . .
Day 4	Doctrine and Covenants 89 . . . . .	Day 3	Doctrine and Covenants 131 . . . . .
		Day 4	Doctrine and Covenants 132:1–33 . . . . .
Unit 20			319
Day 1	Doctrine and Covenants 90–92 . . . . .	Unit 29	
Day 2	Doctrine and Covenants 93 . . . . .	Day 1	Doctrine and Covenants 133:1–35 . . . . .
Day 3	Doctrine and Covenants 94–96 . . . . .	Day 2	Doctrine and Covenants 133:36–74 . . . . .
Day 4	Doctrine and Covenants 97 . . . . .	Day 3	Doctrine and Covenants 134 . . . . .
		Day 4	Doctrine and Covenants 135 . . . . .
Unit 21			330
Day 1	Doctrine and Covenants 98 . . . . .	Unit 30	
Day 2	Doctrine and Covenants 99–100 . . . . .	Day 1	Succession in the Presidency . . . . .
Day 3	Doctrine and Covenants 101:1–16 . . . . .	Day 2	Leaving Nauvoo; the Trek across Iowa; Doctrine and Covenants 136:1–18 . . . . .
Day 4	Doctrine and Covenants 101:17–42 . . . . .	Day 3	Doctrine and Covenants 136:19–42 . . . . .
		Day 4	Handcart Pioneers, 1856–60 . . . . .
Unit 22			345
Day 1	Doctrine and Covenants 101:43–101; 102 . . . . .	Unit 31	
Day 2	Doctrine and Covenants 103 . . . . .	Day 1	The Utah War and the Mountain Meadows Massacre . . . . .
Day 3	Doctrine and Covenants 104 . . . . .	Day 2	The Coming Forth of the Pearl of Great Price . . . . .
Day 4	Doctrine and Covenants 105 . . . . .	Day 3	Official Declaration 1 and the Continued Development of Temple Work . . . . .
		Day 4	Doctrine and Covenants 138 . . . . .
Unit 23			361
Day 1	Doctrine and Covenants 106; 107:1–20 . . . . .	Unit 32	
Day 2	Doctrine and Covenants 107:21–38 . . . . .	Day 1	Church Organizations and Programs . . . . .
Day 3	Doctrine and Covenants 107:39–100; 108 . . . . .	Day 2	Official Declaration 2 . . . . .
Day 4	Doctrine and Covenants 137 . . . . .	Day 3	Hastening the Work of Salvation . . . . .
		Day 4	The Family: A Proclamation to the World . . . . .
Unit 24			373
Day 1	Doctrine and Covenants 109 . . . . .		
Day 2	Doctrine and Covenants 110 . . . . .		
Day 3	Doctrine and Covenants 111 . . . . .		
Day 4	Doctrine and Covenants 112 . . . . .		
Unit 25			
Day 1	The Church Moves to Northern Missouri . . . . .		
Day 2	Doctrine and Covenants 113–14 . . . . .		
Day 3	Doctrine and Covenants 115–16 . . . . .		
Day 4	Doctrine and Covenants 117–20 . . . . .		

# Introduction to the Home-Study Seminary Program

The home-study seminary program is designed to help you strengthen your understanding of the gospel of Jesus Christ and apply its teachings in your daily life through a study of the scriptures. For your study this school year, you will first complete reading assignments from the scripture text for this course—the Doctrine and Covenants—and then you will complete the individual lessons. Once a week you will meet with a seminary teacher to submit your work and participate in a weekly lesson.



Seminary is a daily religious education program. Prayerfully studying your scriptures should be a daily practice. You will need to work on your seminary assignments each school day, even though you will not attend a seminary class each

day. There are 32 units to be completed during the course. The reading chart on page viii shows what you should study for each unit. Your teacher will help you understand when each unit is due. The lessons in this study guide should each take about 30 minutes to complete, in addition to your daily scripture study.

You should have two scripture study journals (or two notebooks), separate from your personal journal, in which you will write the assignments from the study guide activities. Each week that you meet with your teacher, you should turn in the scripture study journal containing the completed assignments from the study guide activities you completed for that week. Your teacher will read and respond to the assignments and return that scripture study journal to you the following week. You could also write your responses on paper in a loose-leaf binder and turn in the pages you did that week. Then, when your teacher returns the pages, you could put them back into the notebook.

## Using This Manual in a Daily Seminary Program

This manual may be used by teachers and students in a daily seminary program to enhance lessons or for make-up work. However, it is not intended to be given to every daily seminary student. If a student needs to make-up a lesson for credit, the teacher may assign him or her to complete the home-study lesson that corresponds with the lesson that was missed.



# Using the Home-Study Student Study Guide

## Scripture Mastery

Each of the 25 scripture mastery passages found in the Doctrine and Covenants is treated separately in the lesson in which it appears, to help you deepen your mastery of it.

## Introduction to the Scripture Text

The introduction gives some background information and a summary of the scripture text for each lesson.

## Verse Grouping and Content Summary

Verse groupings reflect natural breaks where a change in action or topic occurs. Each is followed by a brief summary of the events or teachings in the verses.

## Recording Answers in the Manual

You will sometimes be asked to write answers in the manual on blank lines or in a chart.

 3. In your scripture study journal, explain how the principles you learned from Doctrine and Covenants 64:10–11 could help a person in the following situations:

- a. A young woman is hurt and embarrassed after learning that some of her peers have been spreading gossip about her. Later, some of these people apologize, but others do not. The young woman forgives those who apologized but holds a grudge against the others.
- b. A young man disobeys a commandment. He prays for forgiveness and discusses the problem with his bishop. However, even after the bishop has assured the young man that he has fully repented, the young man continues to feel unworthy because of this past sin.
- c. A young woman is feeling sad and confused because of the actions of her father. He has abandoned his family. Before he left, he rarely showed love for the family and was often cruel. She does not understand why her father acted this way, and she carries feelings of anger toward him. She knows she should seek to forgive him, but she doesn't think that she can.



Consider if there is anyone whom you need to forgive. At times it can be extremely difficult to forgive another. As you read the following counsel from President Gordon B. Hinckley, look for what you can do if you are struggling to forgive someone: "If there be any who nurture in their hearts the poisonous brew of enmity toward another, I plead with you to ask the Lord for strength to forgive. . . . It may not be easy, and it may not come quickly. But if you will seek it with sincerity and cultivate it, it will come" ("Of You It Is Required to Forgive," *Ensign*, June 1991, 5).

 4. Answer the following question in your scripture study journal: How do you think praying for strength can help you to forgive?

Study Doctrine and Covenants 64:12–14. Note that the Lord taught that our choice to forgive others does not relieve them of responsibility for their actions. They are still accountable to the Lord for the wrongs they have done.

Read Doctrine and Covenants 64:15–17, and notice that the Lord specifically said that He would forgive two of His servants, Isaac Morley and Edward Partridge, because they would repent of their sins.

At the beginning of this lesson, you learned that the Lord is compassionate, forgiving, and merciful. As you forgive, you can become more like Him. Decide how you can apply the principles of forgiveness you have learned today.

## Scripture Mastery—Doctrine and Covenants 64:9–11

Spend a few minutes reading Doctrine and Covenants 64:9–11 out loud. Once you have repeated the scripture passage at least five times, find a sibling, parent, or friend who will help you practice memorizing it. Recite the scripture passage to this person until you can repeat it from memory. Explain to the person how the principles in these verses can help you throughout your life. Then ask the person to sign today's entry in your scripture study journal.

 5. Write the following at the bottom of today's assignments in your scripture study journal:

*I have studied Doctrine and Covenants 64:1–19 and completed this lesson on (date).*

*Additional questions, thoughts, and insights I would like to share with my teacher:*

## UNIT 14: DAY 4

# Doctrine and Covenants 64:20–43

## Introduction

The Prophet Joseph Smith received the revelation recorded in Doctrine and Covenants 64 on September 11, 1831. About two weeks before he received this revelation, the Prophet had returned to Ohio after overseeing the dedication of the land and the temple site of Zion in Independence, Missouri. Doctrine and Covenants 64:20–43 contains the Lord's teachings about the sacrifices He required of the Saints and about the establishment of Zion in the latter days.

## Doctrine and Covenants 64:20–25

*The Lord teaches that He requires our hearts*

On the following lines, write about a time when you felt you sacrificed to follow the Lord's commandments (such as refraining from participating in a sporting event or a similar activity in order to keep the Sabbath day holy):

---



---

Although Joseph Smith was greatly blessed because he remained true to his testimony of the First Vision, he was also severely tested. As you study today, consider what you might learn from the way Joseph Smith responded to opposition to his testimony that can help you with the opposition you may face now or someday in the future.



In Joseph Smith—History, the Prophet described some of the opposition he faced because of his testimony. Read Joseph Smith—History 1:21–23, looking for words and phrases that help you understand what he experienced. According to verse 22, who was primarily involved in persecuting Joseph Smith? As you consider Joseph Smith’s age and circumstances in life, why do you think persecution from these people may have been especially difficult for him?

Notice the phrase near the end of Joseph Smith—History 1:20 that begins with the words “It seems as though. . . .” Beginning with these words, read the remainder of the verse, looking for why Joseph Smith experienced this persecution. According to Joseph, why did he experience great persecution at such a young age?

### Joseph Smith—History 1:24–26

*Although Joseph Smith is hated and persecuted, he remains true to his testimony*

Consider the many different accounts of faith and testimony in the scriptures. Is there another person in the scriptures whose character or strength of testimony you greatly admire?

1. Read Joseph Smith—History 1:24, and identify a person in the scriptures whom Joseph Smith admired and identified with because of the persecutions he faced. In your scripture study journal, answer the following questions:
  - a. How do you think it may have been helpful for Joseph Smith to see things he had in common with the Apostle Paul?
  - b. What lesson can we learn about how to deal with difficult challenges from Joseph Smith’s example of studying and pondering Paul’s experiences?

One lesson we can learn is that **during difficult times we can draw strength from the examples of faithful individuals in the scriptures.** (You may want to write this principle in the margins of your scriptures by Joseph Smith—History 1:24.)

2. In your scripture study journal, write about a time when you have been strengthened by studying the experience of a faithful individual in the scriptures.

In your study of the Doctrine and Covenants this year, you will encounter many individuals with whom you can identify and whose examples you can draw upon for the strength you need.

Ponder this phrase from the Prophet’s testimony in Joseph Smith—History 1:25: “I had seen a vision; I knew it, and I knew that God knew it, and I could not deny it.”

3. In your scripture study journal, answer one or both of the following questions:
  - a. What does the phrase in Joseph Smith—History 1:25 teach you about Joseph Smith’s testimony of the First Vision?
  - b. How can you strengthen your witness of the First Vision?
4. Review Joseph Smith—History 1:24, and then study verse 25, looking for additional doctrines and principles

#### Identifying Principles

A principle is an enduring truth or rule that we can adopt to guide us in making decisions. Identifying principles as you study the scriptures can help you apply the scriptures to your own life.

## Scripture Study Journal Assignments

Scripture study journal assignments are to be written out and given to your teacher each week for feedback. Giving careful thought to your answers will help you have meaningful experiences as you learn and apply truths from the scriptures.

## Doctrines and Principles

As gospel doctrines and principles naturally arise from the scripture text, they are bolded in the lesson to help you recognize them.

## Study Helps

Study helps provide insights and explain practices that can enhance your study and understanding of the scriptures.



## Doctrine and Covenants and Church History Reading Chart

Unit Number	Assigned Sections I Read This Week	Days I Read the Scriptures						
1	Introduction to the Doctrine and Covenants and Church History   D&C 1	S	M	T	W	TH	F	S
2	Joseph Smith—History 1:1–65   D&C 2	S	M	T	W	TH	F	S
3	D&C 3   10   4   5   6   7   Joseph Smith—History 1:66–67	S	M	T	W	TH	F	S
4	D&C 8   9   11   12   13   14   15   16	S	M	T	W	TH	F	S
5	D&C 17   18   19	S	M	T	W	TH	F	S
6	D&C 20   21   22   23	S	M	T	W	TH	F	S
7	D&C 24   25   26   27   28   29:1–29	S	M	T	W	TH	F	S
8	D&C 29:30–50   30   31   32   33   34   35	S	M	T	W	TH	F	S
9	D&C 36   37   38   39   40	S	M	T	W	TH	F	S
10	D&C 41   42   43   44	S	M	T	W	TH	F	S
11	D&C 45   46   47   48	S	M	T	W	TH	F	S
12	D&C 49   50   51   52   53   54   55   56	S	M	T	W	TH	F	S
13	D&C 57   58   59	S	M	T	W	TH	F	S
14	D&C 60   61   62   63   64	S	M	T	W	TH	F	S
15	D&C 65   66   67   68   69   70   71	S	M	T	W	TH	F	S
16	D&C 72   73   74   75   76:1–80	S	M	T	W	TH	F	S
17	D&C 76: 81–119   77   78   79   80   81   82   83	S	M	T	W	TH	F	S
18	D&C 84   85   86   87	S	M	T	W	TH	F	S
19	D&C 88   89	S	M	T	W	TH	F	S
20	D&C 90   91   92   93   94   95   96   97	S	M	T	W	TH	F	S
21	D&C 98   99   100   101:1–42	S	M	T	W	TH	F	S
22	D&C 101:43–101   102   103   104   105	S	M	T	W	TH	F	S
23	D&C 106   107   108   137	S	M	T	W	TH	F	S
24	D&C 109   110   111   112	S	M	T	W	TH	F	S
25	D&C 113   114   115   116   117   118   119   120	S	M	T	W	TH	F	S
26	D&C 121   122   123	S	M	T	W	TH	F	S
27	D&C 124   125   126   127   128	S	M	T	W	TH	F	S
28	D&C 129   130   131   132	S	M	T	W	TH	F	S
29	D&C 133   134   135	S	M	T	W	TH	F	S
30	D&C 136	S	M	T	W	TH	F	S
31	D&C 138   Official Declaration 1   Introduction to the Pearl of Great Price   Articles of Faith	S	M	T	W	TH	F	S
32	Official Declaration 2   “The Family: A Proclamation to the World”	S	M	T	W	TH	F	S

# Welcome to the Doctrine and Covenants and Church History

## What Is the Doctrine and Covenants?

The Doctrine and Covenants is scripture and consists of a collection of divine revelations and inspired declarations that give instruction to Church leaders, Church members, and the inhabitants of the world in our day. It is modern revelation and stands alongside the Bible, the Book of Mormon, and the Pearl of Great Price as one of the four standard works of The Church of Jesus Christ of Latter-day Saints.

President Joseph Fielding Smith explained how valuable the Doctrine and Covenants is to us: “This Doctrine and Covenants contains the word of God to those who dwell here now. It is our book. It belongs to the Latter-day Saints. More precious than gold, the Prophet [Joseph Smith] says we should treasure it more than the riches of the whole earth” (*Doctrines of Salvation*, comp. Bruce R. McConkie, 3 vols. [1954–56], 3:199).

## Why Is Studying the Doctrine and Covenants and Church History Important to Me?

The Lord Jesus Christ Himself gave a charge to those who have access to the Doctrine and Covenants:

“Search these commandments, for they are true and faithful, and the prophecies and promises which are in them shall all be fulfilled.

“What I the Lord have spoken, I have spoken, and I excuse not myself; and though the heavens and the earth pass away, my word shall not pass away, but shall all be fulfilled, whether by mine own voice or by the voice of my servants, it is the same” (D&C 1:37–38).

President Gordon B. Hinckley explained:

“The Doctrine and Covenants is unique among our books of scripture. It is the constitution of the Church. While the Doctrine and Covenants includes writings and statements of various origins, it is primarily a book of revelation given through the Prophet of this dispensation.

“These revelations open with a thundering declaration of the encompassing purposes of God in the restoration of His great latter-day work:

“Hearken, O ye people of my church, saith the voice of him who dwells on high, and whose eyes are upon all men; yea, verily I say: Hearken ye people from afar; and ye that are upon the islands of the sea, listen together.

“For verily the voice of the Lord is unto all men, and there is none to escape; and there is no eye that shall not see, neither ear that shall not hear, neither heart that shall not be penetrated.” (D&C 1:1–2.)

“From that majestic opening there unfolds a wondrous doctrinal panorama that comes from the fountain of eternal truth. Some is direct revelation, with the Lord dictating to His prophet. Some is the language of Joseph Smith, written or spoken as he was moved upon by the Holy Ghost. Also included is his narrative of events that occurred in various circumstances. All brought together, they constitute in very substantial measure the doctrine and the practices of The Church of Jesus Christ of Latter-day Saints. . . .

“The variety of matters the book deals with is amazing. They include principles and procedures concerning the governance of the Church. Unique and remarkable rules of health, with promises both physical and spiritual, are set forth. The covenant of the eternal priesthood is described in a manner not found elsewhere in scripture. The privileges and blessings—and the limitations and opportunities—of the three degrees of glory are announced, building on Paul’s brief mention of a glory of the sun, and of the moon, and of the stars. Repentance is proclaimed in language clear and compelling. The correct mode of baptism is given. The nature of the Godhead, which has troubled theologians for centuries, is described in language understandable to all. The Lord’s law of finance is pronounced, mandating how funds for the operation of the Church are to be acquired and disbursed. Work for the dead is revealed to bless the sons and daughters of God of all generations” (“The Order and Will of God,” *Ensign*, Jan. 1989, 2, 4).

As you study the Doctrine and Covenants, you can become more acquainted with the voice of Jesus Christ (see D&C 18:33–36) and communication from the Holy Ghost (see D&C 8:2–3).

## About the Doctrine and Covenants

The Doctrine and Covenant is comprised of 138 sections and two official declarations. Many of these revelations were first published in book form as the Book of Commandments in 1833. Under the direction of the First Presidency, in successive editions of the Doctrine and Covenants, additional revelations or other matters of record have been added after being presented to and accepted by Church members during conferences of the Church.

The 1876 edition, prepared by Elder Orson Pratt under President Brigham Young's direction, arranged the revelations chronologically and supplied new headings with historical introductions.

In the 1981 edition of the Doctrine and Covenants, three documents were included for the first time. These are sections 137 and 138, setting forth the fundamentals of salvation for the dead, and Official Declaration 2.

The 2013 edition of the Doctrine and Covenants includes revisions to study aids, new photos, updated maps, and adjustments to section introductions. The minor adjustments to the introductions are intended to provide a clearer and more accurate context for the scriptures.

### **Joseph Smith Papers Project**

Much of the historical information in this manual was taken from *History of the Church* and the Joseph Smith Papers Project. Of particular help were volumes 1 and 2 of the Documents series of *The Joseph Smith Papers*, published by the Church Historian's Press (an imprint of the Church History Department of The Church of Jesus Christ of Latter-day Saints). To view digitized images and read transcripts of the original documents in the Joseph Smith Papers Project, visit [josephsmithpapers.org](http://josephsmithpapers.org).



**Joseph Smith**  
1830–44



**Brigham Young**  
1844–77



**John Taylor**  
1877–87



**Wilford Woodruff**  
1887–98



**Lorenzo Snow**  
1898–1901

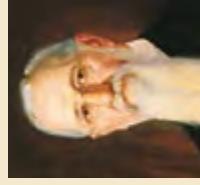

**Joseph F. Smith**  
1901–18



**Heber J. Grant**  
1918–45



**George Albert Smith**  
1945–51

**Church Membership**

**1830**  
6 members

**1873**  
100,000

**1887**  
250,000

**1919**  
500,000

**1947**  
1 million

# Doctrine and Covenants and Church History Chronology



**David O. McKay**  
1951–70



**Joseph Fielding Smith**  
1970–72



**Harold B. Lee**  
1972–73



**Spencer W. Kimball**  
1973–85



**Ezra Taft Benson**  
1985–94



**Howard W. Hunter**  
1994–95



**Gordon B. Hinckley**  
1995–2008



**Thomas S. Monson**  
2008–

**Church Membership**

**1963**  
2 million

**1971**  
3 million

**1982**  
5 million

**1994**  
9 million

**1997**  
10 million

**2010**  
14 million

# Introduction to Scripture Mastery

Seminaries and Institutes of Religion has selected 25 scripture mastery passages for each of the four courses of study in seminary. These 100 passages provide an important scriptural foundation for understanding and sharing the gospel and for strengthening faith.

You are encouraged to develop a mastery of these passages. Mastery of scripture passages includes the following:

- Locating the verses by knowing the associated scripture references
- Understanding the context and content of the scripture passages
- Applying the gospel doctrines and principles taught in the scripture passages
- Memorizing the passages

In this study guide you will study each of the 25 scripture mastery passage as it arises in the Doctrine and Covenants and Church history course of study. Mastering scripture passages takes effort on your part. Consistency and repetition in learning scripture mastery will help you place truths in your long-term memory for future use. You could decide to spend a few minutes each day reviewing scripture mastery passages. Look for opportunities to use them as you explain basic doctrines of the gospel to others.



# 100 Scripture Mastery Passages

The following is a list of all 100 scripture mastery passages:

Old Testament	New Testament	Book of Mormon	Doctrine and Covenants
Moses 1:39	Matthew 5:14–16	1 Nephi 3:7	JS—H 1:15–20
Moses 7:18	Matthew 11:28–30	2 Nephi 2:25	D&C 1:37–38
Abraham 3:22–23	Matthew 16:15–19	2 Nephi 2:27	D&C 6:36
Genesis 1:26–27	Matthew 22:36–39	2 Nephi 9:28–29	D&C 8:2–3
Genesis 2:24	Matthew 28:19–20	2 Nephi 25:23, 26	D&C 10:5
Genesis 39:9	Luke 24:36–39	2 Nephi 28:7–9	D&C 13:1
Exodus 19:5–6	John 3:5	2 Nephi 31:19–20	D&C 18:10–11
Exodus 20:3–17	John 14:6	2 Nephi 32:3	D&C 18:15–16
Joshua 24:15	John 14:15	2 Nephi 32:8–9	D&C 19:16–19
1 Samuel 16:7	John 17:3	Mosiah 2:17	D&C 19:23
Psalms 24:3–4	Acts 2:36–38	Mosiah 3:19	D&C 25:13
Psalms 119:105	Acts 3:19–21	Mosiah 4:30	D&C 46:33
Psalms 127:3	1 Corinthians 6:19–20	Alma 7:11–13	D&C 58:27
Proverbs 3:5–6	1 Corinthians 15:20–22	Alma 32:21	D&C 58:42–43
Isaiah 1:18	1 Corinthians 15:40–42	Alma 37:35	D&C 64:9–11
Isaiah 5:20	Galatians 5:22–23	Alma 39:9	D&C 76:22–24
Isaiah 29:13–14	Ephesians 4:11–14	Alma 41:10	D&C 76:40–41
Isaiah 53:3–5	Philippians 4:13	Helaman 5:12	D&C 78:19
Isaiah 58:6–7	2 Thessalonians 2:1–3	3 Nephi 12:48	D&C 82:10
Isaiah 58:13–14	2 Timothy 3:15–17	3 Nephi 18:15, 20–21	D&C 88:124
Jeremiah 1:4–5	Hebrews 12:9	Ether 12:6	D&C 89:18–21
Ezekiel 37:15–17	James 1:5–6	Ether 12:27	D&C 107:8
Amos 3:7	James 2:17–18	Moroni 7:41	D&C 121:36, 41–42
Malachi 3:8–10	1 Peter 4:6	Moroni 7:45, 47–48	D&C 130:22–23
Malachi 4:5–6	Revelation 20:12	Moroni 10:4–5	D&C 131:1–4

# Introduction to Basic Doctrines

The following is a list of Basic Doctrines of the gospel:

- Godhead
- Plan of salvation
- Atonement of Jesus Christ
- Dispensation, apostasy, and restoration
- Prophets and revelation
- Priesthood and priesthood keys
- Ordinances and covenants
- Marriage and family
- Commandments

As you study the scriptures, seek to identify, understand, believe, explain, and apply these basic doctrines of the gospel. Doing so will help you strengthen your testimony and increase your appreciation for the restored gospel of Jesus Christ. Learning the Basic Doctrines will also help you be better prepared to live the gospel and teach these important truths to others. Other significant doctrines of the gospel will also be emphasized in this manual, even though they are not listed among the Basic Doctrines.

# Basic Doctrines

The Basic Doctrines should be highlighted in both seminary and institute classes. Teachers are to help students identify, understand, believe, explain, and apply these doctrines of the gospel. Doing so will help students strengthen their testimonies and increase their appreciation for the restored gospel of Jesus Christ. A study of these doctrines will also help students be better prepared to teach these important truths to others.

Most of the 100 scripture mastery passages selected by Seminaries and Institutes of Religion were chosen to support students' understanding of the Basic Doctrines. The majority of the scripture references listed in this document refer to scripture mastery passages. They have been included to show how they relate to the Basic Doctrines.

## 1. Godhead

There are three separate personages in the Godhead: God, the Eternal Father; His Son, Jesus Christ; and the Holy Ghost (see Joseph Smith—History 1:15–20). The Father and the Son have tangible bodies of flesh and bone, and the Holy Ghost is a personage of spirit (see D&C 130:22–23). They are one in purpose and doctrine. They are perfectly united in bringing to pass Heavenly Father's divine plan of salvation.

### *God the Father*

God the Father is the Supreme Ruler of the universe. He is the Father of our spirits (see Hebrews 12:9). He is perfect, has all power, and knows all things. He is also a God of perfect mercy, kindness, and charity.

### *Jesus Christ*

Jesus Christ is the Firstborn of the Father in the spirit and is the Only Begotten of the Father in the flesh. He is Jehovah of the Old Testament and the Messiah of the New Testament.

Jesus Christ lived a sinless life and made a perfect Atonement for the sins of all mankind (see Alma 7:11–13). His life is the perfect example of how all mankind should live (see John 14:6; 3 Nephi 12:48). He was the first person on this earth to be resurrected (see 1 Corinthians 15:20–22). He will come again in power and glory and will reign on the earth during the Millennium.

All prayers, blessings, and priesthood ordinances should be done in the name of Jesus Christ (see 3 Nephi 18:15, 20–21).

Related references: Helaman 5:12; D&C 19:23; D&C 76:22–24

### *The Holy Ghost*

The Holy Ghost is the third member of the Godhead. He is a personage of spirit without a body of flesh and bones. He is often referred to as the Spirit, the Holy Spirit, the Spirit of God, the Spirit of the Lord, and the Comforter.

The Holy Ghost bears witness of the Father and the Son, reveals the truth of all things, and sanctifies those who repent and are baptized (see Moroni 10:4–5).

Related references: Galatians 5:22–23; D&C 8:2–3

## 2. Plan of Salvation

In the premortal existence, Heavenly Father introduced a plan to enable us to become like Him and obtain immortality and eternal life (see Moses 1:39). The scriptures refer to this plan as the plan of salvation, the great plan of happiness, the plan of redemption, and the plan of mercy.

The plan of salvation includes the Creation, the Fall, the Atonement of Jesus Christ, and all of the laws, ordinances, and doctrines of the gospel. Moral agency—the ability to choose and act for ourselves—is also essential in Heavenly Father's plan (see 2 Nephi 2:27). Because of this plan, we can be perfected through the Atonement, receive a fulness of joy, and live forever in the presence of God (see 3 Nephi 12:48). Our family relationships can last throughout the eternities.

Related references: John 17:3; D&C 58:27

### *Premortal Life*

Before we were born on the earth, we lived in the presence of our Heavenly Father as His spirit children (see Abraham 3:22–23). In this premortal existence we participated in a council with Heavenly Father's other spirit children. During that council, Heavenly Father presented His plan and the premortal Jesus Christ covenanted to be the Savior.

We used our agency to follow Heavenly Father's plan. We prepared to come to earth, where we could continue to progress.

Those who followed Heavenly Father and Jesus Christ were permitted to come to the earth to experience mortality and progress toward eternal life. Lucifer, another spirit son of God, rebelled against the plan. He became Satan, and he and his followers were cast out of heaven and denied the privileges of receiving a physical body and experiencing mortality.

Related reference: Jeremiah 1:4–5

### *The Creation*

Jesus Christ created the heavens and the earth under the direction of the Father. The earth was not created from nothing; it was organized from existing matter. Jesus Christ has created worlds without number (see D&C 76:22–24).

The Creation of the earth was essential to God's plan. It provided a place where we could gain a physical body, be tested and tried, and develop divine attributes.

We are to use the earth's resources with wisdom, judgment, and thanksgiving (see D&C 78:19).

Adam was the first man created on the earth. God created Adam and Eve in His own image. All human beings—male and female—are created in the image of God (see Genesis 1:26–27).

### ***The Fall***

In the Garden of Eden, God commanded Adam and Eve not to partake of the fruit of the tree of knowledge of good and evil; the consequence of doing so would be spiritual and physical death. Spiritual death is separation from God. Physical death is the separation of the spirit from the mortal body. Because Adam and Eve transgressed God's command, they were cast out from His presence and became mortal. Adam and Eve's transgression and the resultant changes they experienced, including spiritual and physical death, are called the Fall.

As a result of the Fall, Adam and Eve and their posterity could experience joy and sorrow, know good and evil, and have children (see 2 Nephi 2:25). As descendants of Adam and Eve, we inherit a fallen condition during mortality. We are separated from the presence of the Lord and subject to physical death. We are also tested by the difficulties of life and the temptations of the adversary. (See Mosiah 3:19.)

The Fall is an integral part of Heavenly Father's plan of salvation. It has a twofold direction—downward yet forward. In addition to introducing physical and spiritual death, it gave us the opportunity to be born on the earth and to learn and progress.

### ***Mortal Life***

Mortal life is a time of learning when we can prepare for eternal life and prove that we will use our agency to do all that the Lord has commanded. During this mortal life, we are to love and serve others (see Mosiah 2:17; Moroni 7:45, 47–48).

In mortality, our spirits are united with our physical bodies, giving us opportunities to grow and develop in ways that were not possible in the premortal life. Our bodies are an important part of the plan of salvation and should be respected as a gift from our Heavenly Father (see 1 Corinthians 6:19–20).

Related references: Joshua 24:15; Matthew 22:36–39; 2 Nephi 28:7–9; Alma 41:10; D&C 58:27

### ***Life after Death***

When we die, our spirits enter the spirit world and await the Resurrection. The spirits of the righteous are received into a state of happiness, which is called paradise. Many of the faithful will preach the gospel to those in spirit prison.

Spirit prison is a temporary place in the postmortal world for those who die without knowledge of the truth and for those who are disobedient in mortality. There, spirits are taught the gospel and have the opportunity to repent and accept ordinances of salvation that are performed for them in

temples (see 1 Peter 4:6). Those who accept the gospel will dwell in paradise until the Resurrection.

Resurrection is the reuniting of our spirit bodies with our perfected physical bodies of flesh and bones (see Luke 24:36–39). After resurrection, the spirit and body will never again be separated and we will be immortal. Every person born on earth will be resurrected because Jesus Christ overcame death (see 1 Corinthians 15:20–22). The righteous will be resurrected before the wicked and will come forth in the First Resurrection.

The Final Judgment will occur after the Resurrection. Jesus Christ will judge each person to determine the eternal glory that he or she will receive. This judgment will be based on each person's obedience to God's commands (see Revelation 20:12; Mosiah 4:30).

There are three kingdoms of glory (see 1 Corinthians 15:40–42). The highest of these is the celestial kingdom. Those who are valiant in the testimony of Jesus and obedient to the principles of the gospel will dwell in the celestial kingdom in the presence of God the Father and His Son, Jesus Christ (see D&C 131:1–4).

The second of the three kingdoms of glory is the terrestrial kingdom. Those who dwell in this kingdom will be the honorable men and women of the earth who were not valiant in the testimony of Jesus.

The telestial kingdom is the lowest of the three kingdoms of glory. Those who inherit this kingdom will be those who chose wickedness rather than righteousness during their mortal lives. These individuals will receive their glory after being redeemed from spirit prison.

Related reference: John 17:3

## **3. Atonement of Jesus Christ**

To atone is to suffer the penalty for sin, thereby removing the effects of sin from the repentant sinner and allowing him or her to be reconciled to God. Jesus Christ was the only one capable of making a perfect atonement for all mankind. His Atonement included His suffering for the sins of mankind in the Garden of Gethsemane, the shedding of His blood, His suffering and death on the cross, and His Resurrection from the tomb (see Luke 24:36–39; D&C 19:16–19). The Savior was able to carry out the Atonement because He kept Himself free from sin and had power over death. From His mortal mother, He inherited the ability to die. From His immortal Father, He inherited the power to take up His life again.

Through grace, made available by the Savior's atoning sacrifice, all people will be resurrected and receive immortality. The Atonement of Jesus Christ also makes it possible for us to receive eternal life (see Moroni 7:41). To receive this gift, we must live the gospel of Jesus Christ, which includes having faith in Him, repenting of our sins, being baptized, receiving the gift of the Holy Ghost, and enduring faithfully to the end (see John 3:5).

As part of His Atonement, Jesus Christ not only suffered for our sins but also took upon Himself the pains, sicknesses, and infirmities of all people (see Alma 7:11–13). He understands our suffering because He has experienced it. His grace, or enabling power, strengthens us to bear burdens and accomplish tasks that we could not do on our own (see Matthew 11:28–30; Philippians 4:13; Ether 12:27).

Related references: John 3:5; Acts 3:19–21

### ***Faith in Jesus Christ***

Faith is a “hope for things which are not seen, which are true” (Alma 32:21; see also Ether 12:6). It is a gift from God.

Faith must be centered in Jesus Christ in order for it to lead a person to salvation. Having faith in Jesus Christ means relying completely on Him and trusting in His infinite Atonement, power, and love. It includes believing His teachings and believing that even though we do not understand all things, He does (see Proverbs 3:5–6; D&C 6:36).

More than passive belief, faith is expressed by the way we live (see James 2:17–18). Faith can increase as we pray, study the scriptures, and obey God’s commandments.

Latter-day Saints also have faith in God the Father, the Holy Ghost, and priesthood power as well as other important aspects of the restored gospel. Faith helps us receive spiritual and physical healing and strength to press forward, face our hardships, and overcome temptation (see 2 Nephi 31:19–20). The Lord will work mighty miracles in our lives according to our faith.

Through faith in Jesus Christ, a person may obtain a remission of sins and eventually be able to dwell in God’s presence.

Related reference: Matthew 11:28–30

### ***Repentance***

Repentance is a change of mind and heart that gives us a fresh view about God, about ourselves, and about the world. It includes turning away from sin and turning to God for forgiveness. It is motivated by love for God and the sincere desire to obey His commandments.

Our sins make us unclean—unworthy to return to and dwell in the presence of our Heavenly Father. Through the Atonement of Jesus Christ, our Father in Heaven has provided the only way for us to be forgiven of our sins (see Isaiah 1:18).

Repentance also includes feeling sorrow for committing sin, confessing to Heavenly Father and to others if necessary, forsaking sin, seeking to restore as far as possible all that has been damaged by one’s sins, and living a life of obedience to God’s commandments (see D&C 58:42–43).

Related references: Isaiah 53:3–5; John 14:6; 2 Nephi 25:23, 26; D&C 18:10–11; D&C 19:23; D&C 76:40–41

## **4. Dispensation, Apostasy, and Restoration**

### ***Dispensation***

A dispensation is a period of time when the Lord reveals His doctrines, ordinances, and priesthood. It is a period in which the Lord has at least one authorized servant on the earth who bears the holy priesthood and who has a divine commission to dispense the gospel and to administer the ordinances thereof. Today we are living in the last dispensation—the dispensation of the fulness of times, which began with the revelation of the gospel to Joseph Smith.

Previous dispensations are identified with Adam, Enoch, Noah, Abraham, Moses, and Jesus Christ. In addition, there have been other dispensations, including those among the Nephites and the Jaredites. The plan of salvation and the gospel of Jesus Christ have been revealed and taught in every dispensation.

### ***Apostasy***

When people turn away from the principles of the gospel and do not have priesthood keys, they are in a state of apostasy.

Periods of general apostasy have occurred throughout the history of the world. One example is the Great Apostasy, which occurred after the Savior established His Church (see 2 Thessalonians 2:1–3). Following the deaths of the Savior’s Apostles, the principles of the gospel were corrupted and unauthorized changes were made in Church organization and priesthood ordinances. Because of this widespread wickedness, the Lord withdrew the authority and keys of the priesthood from the earth.

During the Great Apostasy, people were without divine direction from living prophets. Many churches were established, but they did not have the authority to confer the gift of the Holy Ghost or perform other priesthood ordinances. Parts of the holy scriptures were corrupted or lost, and the people no longer had an accurate understanding of God.

This apostasy lasted until Heavenly Father and His Beloved Son appeared to Joseph Smith and initiated the Restoration of the fulness of the gospel.

### ***Restoration***

The Restoration is God’s reestablishment of the truths and ordinances of His gospel among His children on the earth (see Acts 3:19–21).

In preparation for the Restoration, the Lord raised up noble men during what is called the Reformation. They attempted to return religious doctrine, practices, and organization to the way the Savior had established them. They did not, however, have the priesthood or the fulness of the gospel.

The Restoration began in 1820 when God the Father and His Son, Jesus Christ, appeared to Joseph Smith in response to his prayer (see Joseph Smith—History 1:15–20). Some of the key events of the Restoration were the translation



of the Book of Mormon, the restoration of the Aaronic and Melchizedek Priesthoods, and the organization of the Church on April 6, 1830.

The Aaronic Priesthood was restored to Joseph Smith and Oliver Cowdery by John the Baptist on May 15, 1829. The Melchizedek Priesthood and keys of the kingdom were also restored in 1829, when the Apostles Peter, James, and John conferred them upon Joseph Smith and Oliver Cowdery.

The fulness of the gospel has been restored, and The Church of Jesus Christ of Latter-day Saints is “the only true and living church upon the face of the whole earth” (D&C 1:30). The Church will eventually fill the whole earth and stand forever.

Related references: Isaiah 29:13–14; Ezekiel 37:15–17; Ephesians 4:11–14; James 1:5–6

## 5. Prophets and Revelation

A prophet is a person who has been called by God to speak for Him (see Amos 3:7). Prophets testify of Jesus Christ and teach His gospel. They make known God’s will and true character. They denounce sin and warn of its consequences. At times, they prophesy of future events (see D&C 1:37–38). Many teachings of prophets are found in the scriptures. As we study the words of prophets, we can learn truth and receive guidance (see 2 Nephi 32:3).

We sustain the President of the Church as a prophet, seer, and revelator and the only person on the earth who receives revelation to guide the entire Church. We also sustain the counselors in the First Presidency and the members of the Quorum of the Twelve Apostles as prophets, seers, and revelators.

Revelation is communication from God to His children. When the Lord reveals His will to the Church, He speaks through His prophet. The scriptures—the Bible, Book of Mormon, Doctrine and Covenants, and Pearl of Great Price—contain revelations given through ancient and latter-day prophets. The President of The Church of Jesus Christ of Latter-day Saints is God’s prophet on the earth today.

Individuals can receive revelation to help them with their specific needs, responsibilities, and questions and to help strengthen their testimonies. Most revelations to leaders and members of the Church come through impressions and thoughts from the Holy Ghost. The Holy Ghost speaks to our minds and hearts in a still, small voice (see D&C 8:2–3). Revelation can also come through visions, dreams, and visitations by angels.

Related references: Psalm 119:105; Ephesians 4:11–14; 2 Timothy 3:15–17; James 1:5–6; Moroni 10:4–5

## 6. Priesthood and Priesthood Keys

The priesthood is the eternal power and authority of God. Through the priesthood, God created and governs the heavens and the earth. Through this power He redeems and

exalts His children, bringing to pass “the immortality and eternal life of man” (Moses 1:39).

God gives priesthood authority to worthy male members of the Church so they can act in His name for the salvation of His children. The keys of the priesthood are the rights of presidency, or the power given to man by God to govern and direct the kingdom of God on the earth (see Matthew 16:15–19). Through these keys, priesthood holders can be authorized to preach the gospel and administer the ordinances of salvation. All who serve in the Church are called under the direction of one who holds priesthood keys. Thus, they are entitled to the power needed to serve and fulfill the responsibilities of their callings.

Related reference: D&C 121:36, 41–42

### *Aaronic Priesthood*

The Aaronic Priesthood is often called the preparatory priesthood. The offices of the Aaronic Priesthood are deacon, teacher, priest, and bishop. In the Church today, worthy male members may receive the Aaronic Priesthood beginning at age 12.

The Aaronic Priesthood “holds the keys of the ministering of angels, and of the gospel of repentance, and of baptism” (D&C 13:1).

### *Melchizedek Priesthood*

The Melchizedek Priesthood is the higher, or greater, priesthood and administers in spiritual things (see D&C 107:8). This greater priesthood was given to Adam and has been on the earth whenever the Lord has revealed His gospel.

It was first called “the Holy Priesthood, after the Order of the Son of God” (D&C 107:3). It later became known as the Melchizedek Priesthood, named after a great high priest who lived during the time of the prophet Abraham.

Within the Melchizedek Priesthood are the offices of elder, high priest, patriarch, Seventy, and Apostle. The President of the Melchizedek Priesthood is the President of the Church.

Related reference: Ephesians 4:11–14

## 7. Ordinances and Covenants

### *Ordinances*

In The Church of Jesus Christ of Latter-day Saints, an ordinance is a sacred, formal act that has spiritual meaning. Each ordinance was designed by God to teach spiritual truths. The ordinances of salvation are performed by the authority of the priesthood and under the direction of those who hold priesthood keys. Some ordinances are essential to exaltation and are called saving ordinances.

The first saving ordinance of the gospel is baptism by immersion in water by one having authority. Baptism is necessary for an individual to become a member of the Church and to enter the celestial kingdom (see John 3:5).

The word *baptism* comes from a Greek word meaning to dip or immerse. Immersion is symbolic of the death of a person's sinful life and his or her rebirth into a spiritual life, dedicated to the service of God and His children. It is also symbolic of death and resurrection.

After a person is baptized, one or more Melchizedek Priesthood holders lay their hands on the person's head and confirm him or her a member of the Church. As part of this ordinance, called confirmation, the person is given the gift of the Holy Ghost.

The gift of the Holy Ghost is different from the influence of the Holy Ghost. Before baptism, a person can feel the influence of the Holy Ghost from time to time and through that influence can receive a testimony of the truth (see Moroni 10:4–5). After receiving the gift of the Holy Ghost, a person has the right to His constant companionship if he or she keeps the commandments.

Other saving ordinances include ordination to the Melchizedek Priesthood (for men), the temple endowment, and the marriage sealing (see D&C 131:1–4). All saving ordinances of the priesthood are accompanied by covenants. In the temple, these saving ordinances can also be performed vicariously for the dead. Vicarious ordinances become effective only when the deceased persons accept them in the spirit world and honor the related covenants.

Other ordinances, such as administering to the sick and the naming and blessing of children, are also important to our spiritual development.

Related reference: Acts 2:36–38

### **Covenants**

A covenant is a sacred agreement between God and man. God gives the conditions for the covenant, and we agree to do what He asks us to do; God then promises us certain blessings for our obedience (see D&C 82:10).

All the saving ordinances of the priesthood are accompanied by covenants. We covenant with the Lord at baptism and renew those covenants by partaking of the sacrament. Brethren who receive the Melchizedek Priesthood enter into the oath and covenant of the priesthood. We make further covenants in the temple.

Related references: Exodus 19:5–6; Psalm 24:3–4; 2 Nephi 31:19–20; D&C 25:13

## **8. Marriage and Family**

Marriage between a man and a woman is ordained of God, and the family is central to His plan of salvation and to our happiness. Happiness in family life is most likely to be achieved when founded upon the teachings of the Lord Jesus Christ.

The sacred powers of procreation are to be employed only between a man and a woman, lawfully wedded as husband and wife. Parents are to multiply and replenish the earth, rear their children in love and righteousness, and provide for the physical and spiritual needs of their children.

Husband and wife have a solemn responsibility to love and care for each other. Fathers are to preside over their families in love and righteousness and provide the necessities of life. Mothers are primarily responsible for the nurture of their children. In these sacred responsibilities, fathers and mothers are obligated to help one another as equal partners.

The divine plan of happiness enables family relationships to continue beyond the grave. The earth was created and the gospel was revealed so that families could be formed, sealed, and exalted eternally. (Adapted from “The Family: A Proclamation to the World,” *Ensign*, Nov. 2010, 129; see also [LDS.org/topics/family-proclamation](http://LDS.org/topics/family-proclamation).)

Related references: Genesis 2:24; Psalm 127:3; Malachi 4:5–6; D&C 131:1–4

## **9. Commandments**

Commandments are the laws and requirements that God gives to mankind. We manifest our love for Him by keeping His commandments (see John 14:15). Keeping the commandments will bring blessings from the Lord (see D&C 82:10).

The two most basic commandments are “love the Lord thy God with all thy heart, and with all thy soul, and with all thy mind. . . . And . . . love thy neighbour as thyself” (Matthew 22:36–39).

The Ten Commandments are a vital part of the gospel and are eternal principles that are necessary for our exaltation (see Exodus 20:3–17). The Lord revealed them to Moses in ancient times, and He has restated them in latter-day revelations.

Other commandments include praying daily (see 2 Nephi 32:8–9), teaching the gospel to others (see Matthew 28:19–20), keeping the law of chastity (see D&C 46:33), paying a full tithe (see Malachi 3:8–10), fasting (see Isaiah 58:6–7), forgiving others (see D&C 64:9–11), having a spirit of gratitude (see D&C 78:19), and observing the Word of Wisdom (see D&C 89:18–21).

Related references: Genesis 39:9; Isaiah 58:13–14; 1 Nephi 3:7; Mosiah 4:30; Alma 37:35; Alma 39:9; D&C 18:15–16; D&C 88:124

For more information on these topics, go to [LDS.org](http://LDS.org), Teachings, Gospel Topics; or see *True to the Faith: A Gospel Reference* (2004).





# The Plan of Salvation

## Introduction

Have you ever wondered why God has commanded us to do some things and not do others? An overview of Heavenly Father’s plan for our salvation, sometimes called the plan of happiness, can help us better understand the purpose of His commandments. President Boyd K. Packer, President of the Quorum of the Twelve Apostles, said, “A knowledge of the plan of happiness, even in outline form, can give young minds a ‘why’” (“The Great Plan of Happiness” [address to CES religious educators, Aug. 10, 1993], 3, si.lds.org).

This lesson provides a brief overview of the plan of salvation. It focuses on the Atonement of Jesus Christ, which is, as Elder Jeffrey R. Holland of the Quorum of the Twelve Apostles taught, “the central fact, the crucial foundation, and the chief doctrine of the great and eternal plan of salvation” (“Missionary Work and the Atonement,” *Ensign*, Mar. 2001, 8).

## Heavenly Father’s Plan for Our Happiness

God revealed the purpose of His plan of salvation to Moses as they spoke face to face on a mountain. Read Moses 1:39, and look for what God stated is His purpose.

Do you know the difference between “immortality” and “eternal life”? Immortality is living forever in a resurrected state. Through Jesus Christ’s Atonement, all who come to earth to receive a physical body will receive this gift. Eternal life, or exaltation, is living forever as families in God’s presence. This gift is also available through the Atonement, but only to those who qualify.

Elder Bruce R. McConkie of the Quorum of the Twelve Apostles explained: “As used in the scriptures, *eternal life* is the name given to the kind of life that our Eternal Father lives. . . . *God’s life is eternal life; eternal life is God’s life*—the expressions are synonymous” (*Mormon Doctrine*, 2nd ed. [1966], 237).



Elder Joseph B. Wirthlin of the Quorum of the Twelve Apostles taught:

“Immortality is about quantity. Eternal life is about quality. . . .

“Eternal life is the culmination of existence. As spiritual children of God, you and I are heirs to this priceless fortune, benefactors to a glorious future, recipients of grace.

“If immortality is God’s work, then eternal life is God’s glory” (“What Is the Difference between Immortality and Eternal Life?” *New Era*, Nov. 2006, 8).

Eternal life includes living in God’s presence, becoming like Him in body and character, and receiving all that He has, including having an eternal family.

From what you have learned from Moses 1:39, complete the following doctrinal statement concerning Heavenly Father’s plan: **The purpose of Heavenly Father’s plan is for us to receive \_\_\_\_\_.**

In our pre-earth life we lived as spirits in the presence of our Heavenly Father. There we learned about His plan for our happiness and how following that plan would help us fulfill His purposes for us. (See D&C 138:55–56; Abraham 3:22–28.)

## Scripture Study Journals

During your home-study experience you will have the opportunity to respond to questions and share your insights with your teacher in a scripture study journal or notebook. Recording your thoughts and impressions, as well as writing answers to questions from the manual, can invite revelation. Elder Richard G. Scott of the Quorum of the Twelve Apostles taught: “Knowledge carefully recorded is knowledge available in time of need. Spiritually sensitive information should be kept in a sacred place that communicates to the Lord how you treasure it. That practice enhances the likelihood of your receiving further light” (“Acquiring Spiritual Knowledge,” *Ensign*, Nov. 1993, 86). Take your scripture study journal with you to your weekly home-study class so you will be prepared to discuss what you have learned and to show your teacher the work you have done.



**1.** Answer the following questions in your scripture study journal:

- a. From your understanding, how were we different from our Heavenly Father in the pre-earth life?
- b. What did Heavenly Father present to us and put in place to help us become like Him?



**2.** Our Heavenly Father’s plan requires us to leave His presence and experience life on earth. Our life on earth is often called mortality. Ponder for a moment why we needed to leave God’s presence and how mortality helps us grow and become more like our Heavenly Father. Write your thoughts in your scripture study journal.



Concerning our mortal life on earth, President Spencer W. Kimball said: “God has given us a plan. **He has sent us all to earth to obtain bodies and to gain experience and growth**” (*The Teachings of Spencer W. Kimball*, ed. Edward L. Kimball

[1982], 25; emphasis added). How does obtaining a physical body and gaining experience here on earth help us to become more like Heavenly Father? What role do such challenges as temptation, sickness, sorrow, pain, discouragement, disabilities, and other mortal difficulties have in our efforts to receive eternal life and become more like Heavenly Father?

One major obstacle we face in mortality is sin. **Sin prevents us from becoming like our Heavenly Father and returning to live with Him** (see D&C 20:18–20; Moses 6:57). Not only does sin make us unclean, but to sin is also contrary to the nature of God—we cannot continue to sin and still reach our objective of becoming like Heavenly Father (see Alma 41:10–11).

Read Doctrine and Covenants 76:40–42, and mark the way Heavenly Father provided to overcome sin.

The truth that **Jesus Christ suffered and was crucified for the sins of all people** is a central doctrine in Heavenly Father’s plan for us and can give hope to all of Heavenly Father’s children. Take a moment to reflect on what the Savior’s sacrifice means to you.

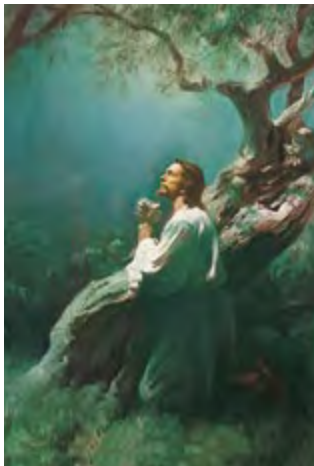

In paying the penalty for our sins, Jesus Christ did not, however, eliminate our personal responsibility. Read Doctrine and Covenants 18:22–23; 25:13, 15, and look for what is required in order for us to receive the cleansing power of the Atonement and return to live in Heavenly Father’s presence. You may want to mark what you find.

 **3.** According to Doctrine and Covenants 18:22–23; 25:13, 15, what must we do to come unto Jesus Christ and receive the blessings of His atoning sacrifice? Write your answer in your scripture study journal.

**If we are obedient to the principles and ordinances of the gospel, we can overcome sin through the grace and Atonement of Jesus Christ** (see Moroni



10:32–33). Because of the Atonement, as we keep the covenant we make at baptism, we can repent and be forgiven of our sins and receive the guidance of the Holy Ghost to direct us along the path toward eternal life.



In addition to sin, there is another obstacle that must be overcome in order to receive eternal life. Read Alma 12:24, and identify the obstacle.

When we die, our spirits and our bodies separate. If our spirits and bodies were separated forever, it would be impossible to become like God.

**We cannot be like Heavenly Father**

**without a body of flesh and bones** (see D&C 93:33–34; 130:22).

Read Alma 11:42–45, and identify how the separation of our spirits and bodies that occurs at death is overcome.

 **4.** Answer the following questions in your scripture study journal:

- a. Why is the Resurrection of Jesus Christ good news for everyone?
- b. How does the hope of the Resurrection bring you joy?

As you read earlier, immortality is a gift of the Atonement of Jesus Christ that all people will receive, regardless of whether they did good or evil during mortality (see Alma 11:42–45; D&C 138:14–17). **Because of the Resurrection of Jesus Christ, all mankind will be resurrected and will**



**live forever.** Eternal life, however, is God’s gift only to those who obey the laws and ordinances of His gospel (see D&C 14:7).

### The Plan of Salvation

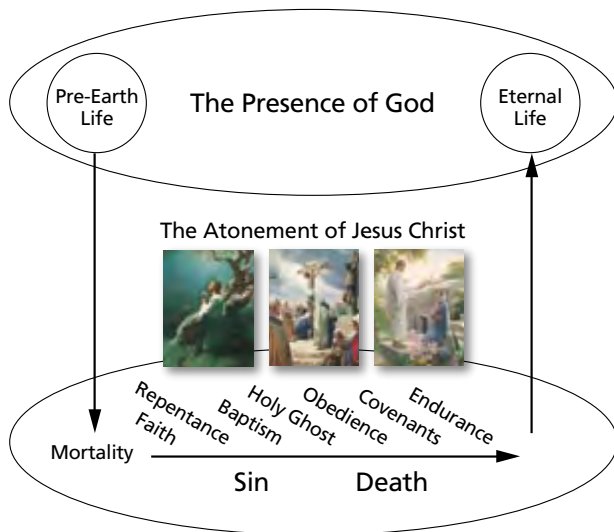

**5.** In your scripture study journal, summarize what you have learned about Heavenly Father’s plan for our happiness. Find a time to teach what you have learned about Heavenly Father’s plan for our salvation to a family member or friend face to face. You might draw the accompanying diagram as you explain it. Be prepared to share your experience with your teacher.

This lesson has presented only a brief overview of the plan of salvation. In your study of the Doctrine and Covenants this year, you will learn many more truths related to the plan of salvation. As you learn more about the plan, watch for what God has done for you, and be sensitive to the Spirit’s promptings about what you need to do to receive the full blessings Heavenly Father offers.

**6.** Write the following at the bottom of today’s assignments in your scripture study journal:

*I have studied “The Plan of Salvation” lesson and completed it on (date).*

*Additional questions, thoughts, and insights I would like to share with my teacher:*

## UNIT 1: DAY 2

# The Great Apostasy

### Introduction

Jesus Christ established His Church during His ministry on the earth. President Henry B. Eyring of the First Presidency explained: “The Apostles, after the Ascension of Christ, continued to exercise the keys He left with them. But because of disobedience and loss of faith by the members, the Apostles died without the keys being passed on to successors. We call that tragic episode ‘the Apostasy’” (“The True and Living Church,” *Ensign* or *Liahona*, May 2008, 21). Because of this widespread apostasy, the priesthood authority was lost from among the people. Understanding about the Great Apostasy helps us better understand the need for the Restoration of the gospel of Jesus Christ in these latter days.

### Jesus Christ Established His Church When He Was on the Earth

In the following chart, match the part to the machine or piece of equipment it belongs to:



How useful are these machines without the parts you matched to them? Compare this to the Lord’s Church. Are there essential parts that if removed from the Church of Jesus Christ would make it unable to function or even exist?



1. In your scripture study journal, write the heading *Essential Elements of Jesus Christ's Church*. As you discover the various elements during this lesson, list them under this heading.

Read Ephesians 2:19–22, and mark the foundation upon which Jesus Christ built His Church during His mortal ministry. Why do you think apostles and prophets are considered the “foundation” of the Church? Who is the cornerstone?

Write the following truth in your list of essential elements of Jesus Christ's Church in your scripture study journal: **Apostles and prophets form the foundation of the Church of Jesus Christ.**

What is happening in the following picture?



Read John 15:16, and look for another element of Jesus Christ's Church that is essential for the salvation of God's children.

Before the Savior's Ascension, He gave His Apostles the authority to direct the Church and act in God's name for the salvation of His children. This priesthood authority includes the priesthood keys, or rights, to direct the Church and perform the ordinances necessary for salvation. Add the following truth to the list in your scripture study journal: **Priesthood authority is necessary to receive the covenants and ordinances of salvation.**



Elder D. Todd Christofferson of the Quorum of the Twelve Apostles described another essential element of the true Church: “The truths and doctrine we have received have come and will continue to come by divine revelation. In some faith traditions . . . doctrinal matters may become a contest of opinions. . . . We value scholarship that enhances understanding, but in the Church today, just as

anciently, establishing the doctrine of Christ or correcting doctrinal deviations is a matter of divine revelation to those the Lord endows with apostolic authority” (“The Doctrine of Christ,” *Ensign* or *Liahona*, May 2012, 86).

According to Elder Christofferson, what is one essential role of apostles and prophets?

A doctrine is a fundamental, eternal truth of the gospel of Jesus Christ. Why do you think it is essential that true doctrine is taught and understood correctly in the Lord's Church? \_\_\_\_\_

Include the following truth in your list in your scripture study journal: **The apostles and prophets establish correct doctrine through divine revelation.**

Although there are many doctrines of the gospel of Jesus Christ, you are encouraged to gain a deeper understanding of the following Basic Doctrines throughout your seminary experience. Doing so will help strengthen your testimony and prepare you to teach the gospel to others.

- Godhead
- Plan of Salvation
- Atonement of Jesus Christ
- Dispensation, Apostasy, and Restoration
- Prophets and Revelation
- Priesthood and Priesthood Keys
- Ordinances and Covenants
- Marriage and Family
- Commandments



2. Choose one of the Basic Doctrines above. In your scripture study journal, write an explanation of why that doctrine is meaningful to you.

Watch for these doctrines throughout your study of the Doctrine and Covenants this year, and seek to deepen your knowledge and understanding of them.

To help you identify another essential element of the Lord's Church, look at the following pictures and consider what they have in common.



An ordinance is a sacred, formal act performed by someone with proper priesthood authority and authorization to perform the ordinance. Why do you think ordinances are an essential part of Jesus Christ’s Church? (To help you answer this question, read John 3:5. Then think about what would happen if you were not able to receive the ordinances of baptism and confirmation and receive the gift of the Holy Ghost.)

A covenant is “an agreement between God and man, but they do not act as equals in the agreement. God gives the conditions for the covenant, and men agree to do what He asks them to do. God then promises men certain blessings for their obedience” (Guide to the Scriptures, “Covenant,” scriptures.lds.org). An ordinance is the means by which we make covenants with God, and blessings come from keeping those covenants.

All of the saving ordinances of the priesthood are accompanied by covenants, which are sacred agreements with God. Add the following truth to the list in your scripture study journal: **In The Church of Jesus Christ of Latter-day Saints, we can receive ordinances that are necessary for our salvation.**

When He was on the earth, Jesus Christ established each of the elements you have learned about as essential parts of His Church. After He died, was

resurrected, and ascended into heaven, He continued to lead and guide His Apostles through revelation. Under the leadership of the Apostles, the ancient Church spread quickly and thousands of people were baptized. Congregations of Saints were formed throughout much of the Roman Empire (this included modern-day Spain, Turkey, Greece, Italy, Syria, and other parts of Europe, Asia, and Africa). Elders, bishops, deacons, priests, teachers, and evangelists (patriarchs) were called and given proper priesthood authority by the Apostles.

### The Great Apostasy Occurred during the Centuries Following the Lord’s Mortal Ministry

Despite the efforts of the Apostles, the early Church faced threats both from within the Church and from outside. Read the following passages of scripture and identify some of these threats:

- Acts 12:1–3 \_\_\_\_\_
- Acts 20:29–30 \_\_\_\_\_
- 2 Timothy 4:1–4 \_\_\_\_\_
- 2 Peter 2:1–2 \_\_\_\_\_

 **3.** Why do you think these threats were so dangerous to the Church? Write your thoughts in your scripture study journal.



President Boyd K. Packer, President of the Quorum of the Twelve Apostles, spoke of the great losses the New Testament Church experienced during this time:

“James was killed in Jerusalem by Herod. Peter and Paul died in Rome. Tradition

holds that Philip went to the East. Much more than this we do not know.

“They scattered; they taught, testified, and established the Church. And they died for their beliefs, and with their deaths came the dark centuries of apostasy” (“The Twelve,” *Ensign or Liahona*, May 2008, 84).

What happens to a structure if the foundation is removed?

The fall of the early Church is called the Great Apostasy. **Apostasy occurs when people turn away from gospel truths and reject the Lord’s authorized servants.**

President Packer further explained the most significant loss resulting from the Great Apostasy: “The most precious thing lost in the Apostasy was the authority held by the Twelve—the priesthood keys. For the Church to be *His* Church, there must be a Quorum



of the Twelve who hold the keys and confer them on others" ("The Twelve," 84).



4. In your scripture study journal, write answers to the following questions:

- a. How would the loss of priesthood authority affect the other essential elements of the Church?
- b. Why was there no way to repair the Church without the prophets and apostles, priesthood authority, and correct knowledge of Jesus Christ's doctrine?

President Packer said of this time in history: "As the centuries passed, the flame flickered and dimmed. Ordinances were changed or abandoned. The line was broken, and the authority to confer the Holy Ghost as a gift was gone. The Dark Ages of apostasy settled over the world" ("The Cloven Tongues of Fire," *Ensign*, May 2000, 8).



5. Answer the following question in your scripture study journal: Why do you think it is important to understand the Great Apostasy and its consequences?

As you study the Doctrine and Covenants and Joseph Smith—History during this seminary course, you will learn that **a restoration of truth and priesthood authority was necessary to overcome the effects of the Great Apostasy**. The Restoration is "God's reestablishment of the truths and ordinances of His gospel among men on earth. The gospel of Jesus Christ was lost from the earth through the apostasy that took place following the earthly ministry of Christ's Apostles. That apostasy made necessary the restoration of the gospel" (Guide to the Scriptures, "Restoration of the Gospel," scriptures.lds.org).

As you study you will recognize how each of the essential elements of the Church of Jesus Christ was restored to the earth through the Prophet Joseph Smith. The Lord has once again established His Church for the purpose of offering salvation to the world.



6. Explain to a family member or friend (in person) the essential elements of the Church of Jesus Christ and how they were lost from the early Church. Explain why it is important to understand the Great Apostasy. In your scripture study journal, write how your conversation went and how your family member or friend responded.



7. Write the following at the bottom of today's assignments in your scripture study journal:

*I have studied "The Great Apostasy" lesson and completed it on (date).*

*Additional questions, thoughts, and insights I would like to share with my teacher:*

## UNIT 1: DAY 3

# Doctrine and Covenants 1

## Introduction

By November 1831 the Prophet Joseph Smith had recorded more than 60 revelations. However, most Church members did not have access to copies of them. The Prophet convened a conference in Hiram, Ohio, to discuss publishing the revelations in a book that would be called the Book of Commandments. A committee of elders drafted a preface to the book. Unsatisfied with this draft, those who attended the conference requested that Joseph Smith ask the Lord for a preface. After petitioning the Lord in prayer, Joseph received a preface by revelation. The Lord's preface to the Book of Commandments is now section 1 of the Doctrine and Covenants.

## Doctrine and Covenants 1:1–16

*The Lord warns of judgments that will come upon the rebellious at the Second Coming*

Consider the following experience of three brothers who were protected from danger because they listened to a warning from their father:



"Mike and his younger brothers, Eric and Tom, liked to go hiking with their dad. Dad always said he knew the mountains like the back of his own hand. He had grown up walking the same paths with his own dad, who was a shepherd. . . .

". . . One summer day [the boys] were excited to reach the top of the

trail—a high meadow filled with fresh green grass and flowers of just about every color. And so they took off running through the trees at top speed, even though they were tired from their morning's hike. They wanted to burst onto that meadow like jackrabbits.

"'Stop when you get to the meadow,' Dad called after them. 'I'll meet you there.' They ran ahead, each trying to get in front of the others. . . .

"[They forgot] Dad's instruction. They ran in circles through the deep grass, jumping and dodging, whooping and hollering and tagging each other. . . .

"Then Eric had an idea. 'Let's race all the way across the meadow!' Tom hesitated. They couldn't see the far side of the clearing because a grassy hill obscured their view. But Mike wasn't worried. 'I think this is the same meadow we came to last summer,' he assured his brothers.

"They gathered back at the trees. 'Ready!' Eric shouted. 'Set! GO!' The wind felt fresh and cool on Mike's cheeks and in his hair, and the faster he ran, the more wind he got. Soon he was leading the race. He felt like he could run forever.

"'STOP!' a voice bellowed like thunder behind them. All three boys stopped immediately. They turned and saw Dad running toward them from the edge of the meadow. 'Come back here beside me,' Dad called, more gently this time. The boys obeyed. . . . [Then] they walked together across the meadow. As they topped the little hill, Dad suddenly stopped.

"Just a few paces ahead of them, a sheer cliff dropped down at least 20 or 30 feet. If they had been running, there was no way they could have seen it in time to stop. . . .

". . . 'We could have died,' Mike said softly.

"'Well, maybe. I'm sure glad you stopped running even though I didn't have time to explain. Sometimes we have to obey first and ask questions later!'

"'Especially when someone else knows what's coming, and you don't,' Mike said" (Ana Nelson Shaw, "Stop!" *Friend*, June 2005, 47–48).

Ponder about a time when someone tried to get your attention and warn you about something. How did you respond? Do you feel grateful for that person's efforts to warn you? Why or why not?

In the Doctrine and Covenants the Lord provides warnings, commandments, and instructions that are crucial for our happiness and salvation. As previously mentioned, the Lord revealed section 1 as a preface to the other revelations in the Doctrine and Covenants. A preface prepares a reader for the



contents of a book by summarizing the message and the author's purpose.

Read Doctrine and Covenants 1:1–3, and identify words or phrases the Lord used to get the readers' attention. (It might help to know that the word *hearken* means to listen attentively and obey.) In the space provided, answer the following questions:

- To whom is the Lord speaking in these verses?

\_\_\_\_\_

- What do you think the phrase "their iniquities shall be spoken upon the housetops, and their secret acts shall be revealed" (D&C 1:3) means? \_\_\_\_\_

\_\_\_\_\_

 **1.** In your scripture study journal, explain why you think it would be important to warn people that sins committed in secret will be made known.

Read Doctrine and Covenants 1:4–7, and identify how the Lord will deliver His warnings to all people.

**The Lord speaks His warnings to all people through His chosen disciples.** The Lord gives warnings through His servants and the scriptures. Review some of the most recent general conference talks from the First Presidency and Quorum of the Twelve Apostles. What counsel or warnings have you heard the Lord's apostles and prophets give recently?

One of the warnings the Lord gives in Doctrine and Covenants 1:8–10 is that He will judge people according to their actions and how they treat others. Read Doctrine and Covenants 1:11–14, and look for further warnings the Lord gave. As you look at the Topical Guide reference in footnote 12b, ponder what event the Lord was referring to in Doctrine and Covenants 1:12.

 **2.** Answer the following question in your scripture study journal: What do you think the Lord's warning that those who do not give heed to His prophets "shall be cut off from among the people" (D&C 1:14) means?

Because of wickedness and apostasy throughout the world, the Lord's warnings are necessary. Those who do not hearken unto the words of His prophets will be separated from the righteous and lose the blessings that are available through the ordinances and covenants of the gospel.

 **3.** Read Doctrine and Covenants 1:15–16. In your scripture study journal, list some of the words or phrases that describe the wickedness or apostasy the Lord said would exist in the last days. Then answer the following question: In what ways do people in our day walk "in [their] own way, and after the image of [their] own god"?



## Doctrine and Covenants 1:17–33

*The gospel was restored through the Prophet Joseph Smith in advance of coming calamity*

Identify the word the Lord used in Doctrine and Covenants 1:17 to refer to the results of the wickedness, apostasy, and destruction that will occur among the people of the earth in the last days.

Doctrine and Covenants 1:17–33 contains the Lord’s solutions to help us through the calamity of the last days. Complete the following chart by reading the scripture references in the left column and identifying the Lord’s solutions to help us through the calamity of the last days. In the center column, write descriptions or draw pictures of what you find in the scripture references. You may also consider drawing a picture of these descriptions on a page of your scripture study journal. In the right column, write brief explanations of how the Lord’s solutions help us with the calamity of the last days.

Scripture reference	What solution did the Lord give for the calamity that would come upon the earth?	How can this solution help us face the calamity of the last days?
D&C 1:17		
D&C 1:18–23		
D&C 1:29		
D&C 1:30		

To help you further ponder the Lord’s declaration in Doctrine and Covenants 1:30, mark words in this verse highlighting the truth that **The Church of Jesus Christ of Latter-day Saints is the only true and living church upon the earth.**



4. Answer the following question in your scripture study journal: Recalling what you learned in the previous lesson about the Great Apostasy, how would you explain to someone why The Church of Jesus Christ of Latter-day Saints is the only true and living church upon the earth?



Elder David A. Bednar of the Quorum of the Twelve Apostles explained what it means to be a part of a “living” church: “This restored Church is true because it is the Savior’s Church; He is ‘the way, the truth, and the life’ (John 14:6). And it is a living church because of the workings and gifts of the Holy Ghost. How blessed we are to live at a time when the priesthood is upon the earth and we can receive the Holy Ghost” (“Receive the Holy Ghost,” *Ensign* or *Liahona*, Nov. 2010, 97).

Through the gift of the Holy Ghost, the Lord is able to direct His Church with ongoing revelation. This continuing revelation is an example of how the Church is a living church.



5. Answer one or both of the following questions in your scripture study journal:

- Why is it important to you to know that you belong to the only true and living church upon the earth?
- What do you think it means in Doctrine and Covenants 1:30 when the Lord stated He was pleased with His Church “collectively and not individually”?

Search Doctrine and Covenants 1:31–33, and match what the Lord said about sin and repentance with the appropriate question in the following chart.

___ 1. The Lord cannot look upon sin how?	a. Light and His Spirit will be taken away
___ 2. How can you be forgiven?	b. With the least degree of allowance
___ 3. What happens to those who do not repent?	c. Repent and keep the commandments

## Doctrine and Covenants 1:34–39

*The Lord directs us to search the revelations and commandments He has given*

Read Doctrine and Covenants 1:34–36, and note the Lord’s warning to all people to prepare for His Second Coming. Read Doctrine and Covenants 1:37–39, and identify the truths the Lord emphasized at the conclusion of His preface to the Doctrine and Covenants. (Doctrine and Covenants 1:37–38 is a scripture mastery passage.)

If you have not done so, you may want to mark words or phrases that teach the following truths: **We are to search the commandments the Lord has given. The Lord’s words will all be fulfilled. The Lord’s words are true whether they are stated by Him or by His servants.**

 **6.** Based on what you have learned today, how can you be blessed if you search the commandments and revelations the Lord has given in the Doctrine and Covenants? Write your thoughts in your scripture study journal.

 **7.** In your scripture study journal, write a goal to study the Doctrine and Covenants daily during the school year. As part of your goal, consider when, where, and for how long or how many pages you will study each day.

### **Scripture Mastery—Doctrine and Covenants 1:37–38**

To help you memorize Doctrine and Covenants 1:37, write the first letter of each word on a piece of paper. Recite Doctrine and Covenants 1:37 (using your scriptures as needed) until you can recite the entire verse using only the first letters. Then erase or cover several of the letters and recite the scripture again. Continue this process until all of the letters have been erased and you can recite the verse entirely from memory. Repeat this process with Doctrine and Covenants 1:38.

 **8.** Write the following at the bottom of today’s assignments in your scripture study journal:

*I have studied Doctrine and Covenants 1 and completed this lesson on (date).*

*Additional questions, thoughts, and insights I would like to share with my teacher:*

## **UNIT 1: DAY 4**

# Studying the Scriptures

### **Introduction**

This lesson will help you learn how to better understand the scriptures, identify gospel doctrines and principles they contain, and apply those truths in your life. As you do so, the scriptures will become a greater source of guidance and revelation in your life.

### **Studying the Scriptures in Seminary**

Have you ever helped someone look for something that was lost? Before you began looking did you have a description of what you were looking for? If you didn’t really know what you were searching for, how successful was your search, or how successful do you think your search would have been?

In a similar way, your scripture study can be more meaningful when you know what to look for as you study.



 **1.** In your scripture study journal, write down what you hope to gain when you study your scriptures.

President Marion G. Romney of the First Presidency taught about one reason the scriptures have been written that can help you know what to look for as you study the scriptures: “One cannot honestly study the scriptures without learning principles because the scriptures have been written to preserve principles for our benefit” (“The Message of the Old Testament” [address to CES religious educators, Aug. 17, 1979], 3, si.lds.org).

According to President Romney, why have the scriptures been written? \_\_\_\_\_

What we are looking for as we study the scriptures, therefore, should be more than just details about the events and people in the scriptures. We should be striving to find the gospel truths that the ancient prophets preserved through the events, sermons, and revelations they recorded in scripture. These truths are called doctrines and principles.

Doctrines are fundamental, unchanging truths of the gospel of Jesus Christ, such as *Heavenly Father has a body of flesh and bones*. Principles are enduring truths or rules we can use to guide us in making decisions and applying the doctrines in our lives. Elder Richard G. Scott of the Quorum of the Twelve Apostles described how gospel principles can benefit us: “Principles are concentrated truth, packaged for application to a wide variety of circumstances. A true principle makes decisions clear even under the most confusing and compelling circumstances” (“Acquiring Spiritual Knowledge,” *Ensign*, Nov. 1993, 86).

According to Elder Scott, what does a principle do for us? \_\_\_\_\_

One example of a principle taught in the scriptures is found in Joseph Smith’s First Vision. From Joseph’s experience, we can learn that **God hears and answers prayers**.



2. Write in your scripture study journal a doctrine or principle you have learned by studying the scriptures.

## Understanding the Context and Content of the Scriptures

Picture a piece of fruit that has a peel or outer shell, such as a banana or orange.

Which part of the fruit is the most useful? What must you do before you can eat the fruit?



If the most important or useful part of the fruit is on the inside, what is the purpose of the outer covering?

---



The fruit within the peel, which we use for strength and nourishment, can be compared to the doctrines and principles found in the scriptures. The peel that surrounds the fruit can be compared to the events and people of the scriptures. Much like the outer covering preserves and helps transport the inner fruit, these scriptural accounts hold and carry gospel doctrines and principles to us in a way that helps us understand, remember, and apply them in our lives.

If you have a piece of fruit available, peel it so you can see the fruit within (or simply think about the different ways you would get to the fruit of a banana or orange). The work needed to remove the outer covering and expose the inner fruit is similar to what we must do to open up or uncover a passage of scripture. To peel open the scriptures and expose the fruit inside, we need to understand the historical setting of a revelation and also strive to understand the events, people, and meaning of words. As we do so, the doctrines and principles contained within the scriptural accounts become easier to see and understand.

The following are some basic methods and skills to help you better understand the scriptures as you study them. At the end of the lesson you will find additional scripture study skills and methods.

**Historical setting:** Each section of the Doctrine and Covenants includes a section introduction that often describes concerns, questions, or historical events that preceded the revelation in that section. Knowing these details can help you understand the revelation.



**3.** To see how knowing the historical setting can increase your understanding of a revelation, read the section introduction to Doctrine and Covenants 121 and verses 1–8. In your scripture study journal, describe how knowing that the Prophet Joseph Smith had been imprisoned in Liberty Jail for several months adds meaning to his prayer and the Lord’s answer in these verses.

**Word definitions:** Some words used in the scriptures may not be familiar. The Bible Dictionary, the Guide to the Scriptures, scripture footnotes, and a regular dictionary can help you understand what those words mean.

For example, read Doctrine and Covenants 121:1, 4. The word *pavilion* refers to a tent or protective structure. How does knowing this help you better understand the meaning of these verses?

**Cross-references:** One scripture passage can often help explain or clarify the meaning of a phrase or concept found in a different passage. For example, read Doctrine and Covenants 10:55. This verse seems to indicate that the only thing required to inherit the celestial kingdom is to be a member of the Church. Now read Doctrine and Covenants 10:67, and notice what it teaches about being a member of the Church.



**4.** In your scripture study journal, explain how Doctrine and Covenants 20:37 helps you understand the meaning of Doctrine and Covenants 10:55 and 10:67. You may want to write *D&C 10:67; 20:37* in the margin by Doctrine and Covenants 10:55 as cross-references.

## Identifying Doctrines and Principles

As you increase your understanding of the background, words, people, and events in the scriptures, you are better prepared to identify the gospel truths contained within them.

Some gospel doctrines and principles are easy to identify because they are stated directly in the scriptures. Read Doctrine and Covenants 130:22, and mark doctrines and principles that are stated directly in this verse. Among the doctrines stated in this verse are the truths that **the Father and the Son have bodies of flesh and bones as tangible as man’s** and **the Holy Ghost is a personage of Spirit**.

Many doctrines and principles are not stated directly in the scripture text but are illustrated or described across several verses. To identify these doctrines and principles, we need to recognize the truths being illustrated in the scripture passage and then state those truths clearly and simply. This often requires time and careful thought.



Elder Richard G. Scott gave the following counsel: “As you seek spiritual knowledge, search for principles. Carefully separate them from the detail used to explain them. . . . It is worth great effort to organize the truth we gather to simple statements of principle” (“Acquiring Spiritual Knowledge,” 86).

As you learn how to identify doctrines and principles that are not directly stated, you might ask questions such as: Why is this information recorded in the scriptures? What did the writer want readers to learn and understand? What can I learn from this that can help me in my life? What can I learn from this that can help me share gospel truths with others?



**5.** Practice identifying doctrines and principles by reviewing Doctrine and Covenants 121:1–8 and asking yourself some of the preceding questions. In your scripture study journal, write one or two truths you learn from the Prophet Joseph Smith’s prayer and the Lord’s answer to that prayer.

## Applying Doctrines and Principles in Your Life

Think again about the fruit discussed earlier in this lesson. What value would the fruit have if it was never used once it was removed from its peel?

If we compare the fruit within the peel to the doctrines and principles we identify in the scriptures, what should we do with these truths once we find them?

---



---



---

The value of the work we do to remove the peel is the nourishment and strength we can receive from the inner fruit. In the same way, the value of scripture study comes as we take the doctrines and principles we identify and apply them in our lives. Many of the revelations in the Doctrine and Covenants were given for individuals with questions or concerns, but we can also apply the counsel and teachings in our own lives. Although most of the sections are directed to members of The Church of Jesus Christ of Latter-day Saints, the messages, warnings, and exhortations are for the benefit of everyone.



**6.** Think of an example of a gospel truth that you have learned from the scriptures and how it blessed your life when you applied it. Record your experience in your scripture study journal.





President Boyd K. Packer, President of the Quorum of the Twelve Apostles, gave the following promise to those who study the scriptures and apply the truths they contain: “If [you] are acquainted with the revelations, there is no question—

personal or social or political or occupational—that need go unanswered. Therein is contained the fulness of the everlasting gospel. Therein we find principles of truth that will resolve every confusion and every problem and every dilemma that will face the human family or any individual in it” (“Teach the Scriptures” [address to CES religious educators, Oct. 14, 1977], 3–4, si.lds.org).

You may want to mark portions of his promise that are meaningful to you.

Consider setting a goal to help you apply one of the truths you have learned during your scripture study today.



**7.** Write the following at the bottom of today’s assignments in your scripture study journal:

*I have studied the “Studying the Scriptures” lesson and completed it on (date).*

*Additional questions, thoughts, and insights I would like to share with my teacher:*

## Additional Scripture Study Skills and Methods

**Name substitution:** To help you apply principles from the scriptures in your life, substitute your name for a name in the scriptures. Try this skill with Doctrine and Covenants 6:20.

**Cause and effect:** To help you identify gospel doctrines and principles in the scriptures, look for if–then and because–therefore relationships. Try this skill with Doctrine and Covenants 5:24.

**Key words:** Words and phrases like “behold,” “wherefore,” “because,” “therefore,” “nevertheless,” or “thus we see” are invitations to stop and look for specific messages. Read Doctrine and Covenants 58:26, and notice how key words can help you identify doctrines and principles.

**Scripture lists:** The scriptures often contain lists, such as lists of character attributes, instructions, or warnings. When you find lists, consider numbering each element. Try this skill with Doctrine and Covenants 4:5–6.

**Contrasts:** The scriptures often show contrasts in ideas, events, and people. These contrasts emphasize gospel principles. Look for contrasts in single verses, in

chapters, and across chapters and books. Try this skill with Doctrine and Covenants 50:23–25.

**Visualization:** Look for descriptive details that can help you create a mental picture of what you read. Imagine being present at certain events. This can help strengthen your testimony of the reality of what you read in the scriptures. Try this skill with Doctrine and Covenants 45:44–46.

**Symbolism:** Words and phrases such as “like,” “as,” or “likened unto” can help you identify symbols. Look beyond a symbol by exploring its nature and pondering its attributes. Footnotes, the Bible Dictionary, and the Topical Guide or Guide to the Scriptures can help you interpret some symbols. Try this skill with Doctrine and Covenants 88:46, 51–61.

**Pondering:** Pondering includes thinking, meditating, asking questions, and evaluating what you know and what you have learned. Pondering often helps us understand what we need to do to apply gospel principles. President David O. McKay taught, “Meditation is one of the most secret, most sacred doors through which we pass into the presence of the Lord” (*Teachings of Presidents of the Church: David O. McKay* [2003], 32). Read Doctrine and Covenants 138:1–4 for an example of someone using this skill.

## UNIT 2: DAY 1

# Joseph Smith— History 1:1–20

## Introduction

In 1838 Joseph Smith began work on his official history. In it he described his family and the places they had lived. He also told about the “unusual excitement” about religion that prevailed in western New York in 1820 (Joseph Smith—History 1:5). This religious fervor led him to “serious reflection and great uneasiness” because of “the confusion and strife among the different denominations” (Joseph Smith—History 1:8).

While searching the scriptures, Joseph read James 1:5 (see Joseph Smith—History 1:11), which exhorts those who need wisdom to “ask of God.” Joseph recorded: “Never did any passage of scripture come with more power to the heart of man than this did at this time to mine. It seemed to enter with great force into every feeling of my heart. I reflected on it again and again, knowing that if any person needed wisdom from

God, I did; for how to act I did not know, and unless I could get more wisdom than I then had, I would never know; for the teachers of religion of the different sects understood the same passages of scripture so differently as to destroy all confidence in settling the question by an appeal to the Bible” (Joseph Smith—History 1:12). He decided to ask God in prayer for answers to his questions. In answer to his prayer, God the Father and His Son, Jesus Christ, appeared to him.

## Joseph Smith—History 1:1–4

### *Joseph Smith begins writing his history*

President Thomas S. Monson, who served as a mission president in Canada, shared the following experience of two of his missionaries:



“The two [missionaries] called at the home of Mr. Elmer Pollard, and he, feeling sympathy for the almost frozen missionaries, invited them in. They presented their message and asked if he would join in prayer. He agreed, on the provision that he could offer the prayer.

“The prayer he offered astonished the missionaries. He said, ‘Heavenly Father, bless these two unfortunate, misguided missionaries, that they may return to their homes and not waste their time telling the people of Canada about a message which is so fantastic and about which they know so little.’

“As they arose from their knees, Mr. Pollard asked the missionaries never to return to his home. As they left, he said mockingly to them, ‘You can’t tell me you really believe that Joseph Smith was a prophet of God, anyway!’ and he slammed the door” (“The Prophet Joseph Smith: Teacher by Example,” *Ensign*, Nov. 2005, 69).

If you were one of the missionaries, what would you have said to Mr. Pollard about the Prophet Joseph Smith?

The Prophet Joseph Smith wrote the account of his life that is found in Joseph Smith—History in 1838 for the purpose of publishing an official history of the Church. Read Joseph Smith—History 1:1–2, and look for the reasons Joseph Smith gave for writing this official history.

Joseph Smith—History includes the Prophet’s firsthand account of the First Vision. There are several known accounts of the First Vision—four of which were written or dictated by Joseph Smith, and others were written by those who retold Joseph’s experience in their own words. These accounts were prepared at different times, for different audiences, and for

different purposes. All of these accounts agree in the essential truth that Joseph Smith did indeed have the heavens opened to him and see divine messengers, including God the Father and the Lord Jesus Christ. Because the 1838 account was part of Joseph Smith’s official history and testimony to the world, it was included in the Pearl of Great Price.

## Joseph Smith—History 1:5–13

### *In the midst of religious confusion, Joseph Smith determines to ask God which church is right*

Joseph Smith lived during a time of great interest and excitement about religion. Read Joseph Smith—History 1:5–7, and look for words or phrases that describe the situation Joseph faced. You may want to mark these words in your scriptures. When you have finished, read Joseph Smith—History 1:8, 10, looking for Joseph Smith’s descriptions of how he felt during this time.



**1.** In your scripture study journal, summarize Joseph Smith—History 1:5–7 by imagining you had to explain Joseph’s situation and predicament to someone who had never heard of Joseph Smith. Include at least three ideas you feel you should emphasize about Joseph Smith.

Think back to a situation that caused you to ask several questions, and ponder what you did to resolve your concerns. Read Joseph Smith—History 1:11, and look for the place Joseph Smith found answers to his questions. Take a moment and repeat aloud or memorize James 1:5 as quoted in verse 11.

One principle contained in James 1:5 that helped Joseph Smith find answers to his questions is that **if we ask God in faith, He will answer our prayers.** Mark the words or phrases that teach this principle in Joseph Smith—History 1:11. Understanding that God will answer our prayers in His own time and way, ponder how you have found this principle to be true in your own life.

Joseph described how this passage of scripture affected him. Read Joseph Smith—History 1:12–13, and identify phrases describing Joseph’s experience and response after reading James 1:5. Has a scripture ever touched your heart with power? According to Joseph Smith—History 1:13, what did Joseph Smith want to overcome? What did he conclude he must do?

## Joseph Smith—History 1:14–20

### *Joseph Smith sees God the Father and His Son, Jesus Christ*

Joseph Smith—History 1:15–20 is a scripture mastery passage. You may want to mark it in a distinctive way.



If you have access to an LDS hymnbook, read the words to “Joseph Smith’s First Prayer” (*Hymns*, no. 26). Then read Joseph Smith—History 1:14–15.

Why do you think Satan tried to stop Joseph Smith from praying? To find out what Joseph Smith did when faced with this “astonishing influence,” read Joseph Smith—History 1:16. What do you think the Prophet meant when he said he exerted “all [his] powers to call upon God”? Ponder what Joseph Smith’s example can teach you about how to respond when you are confronted with a difficult situation or Satan’s temptations.

One of the most important events in human history is recorded in Joseph Smith—History 1:17. As you read this verse, try to visualize this sacred event. One important truth we learn from this verse is that **Joseph Smith saw God the Father and His Son, Jesus Christ**. He also spoke with Them and received instruction from Them. Joseph Smith’s First Vision is the foundational event of the Restoration of the gospel in the latter days.

 **2.** In your scripture study journal, write why you think it is important for you and every member of the Church to have a testimony that Joseph Smith saw God the Father and His Son, Jesus Christ.



Review Joseph Smith—History 1:15–17, and identify additional truths we can learn from the account of the Father and the Son appearing to Joseph Smith.

A temptation or trial may come sometimes before or after a spiritual experience. Joseph Smith experienced a trial right before the First Vision. For Moses, the trial came right after he had spoken with God (see Moses 1:9–12). Joseph Smith learned that **if we earnestly seek God’s help when Satan tries to discourage us, God can deliver us**.

 **3.** In your scripture study journal, answer the following questions:

- a. How does knowing that we can receive God’s help to overcome difficulties and discouragement help you?
- b. What other principles can you learn from Joseph’s experience in Joseph Smith—History 1:15–16 that can help you overcome temptation?

 **4.** What can we learn about the Godhead from Joseph Smith—History 1:15–17? Write your answer in your scripture study journal.

Some of the doctrines concerning the Godhead found in Joseph Smith—History 1:15–17 are: **God the Father and His Son, Jesus Christ, live. Heavenly Father and His Son, Jesus Christ, are separate and distinct beings.**

Joseph Smith inquired of the Lord to learn which of all the churches he should join. Read Joseph Smith—History 1:18–20, and mark the answer Joseph received to this question.

Remember the account of the missionaries shared at the beginning of the lesson? President Monson told what the missionaries did after the man slammed the door on them:

“The missionaries had walked but a short distance when the junior companion said timidly, ‘Elder, we didn’t answer Mr. Pollard.’

“The senior companion responded: ‘We’ve been rejected. Let’s move on.’

“The young missionary persisted, however, and the two returned to Mr. Pollard’s door. Mr. Pollard answered the knock and angrily said, ‘I thought I told you young men never to return!’

“The junior companion then said, with all the courage he could muster, ‘Mr. Pollard, when we left your door, you said that we didn’t really believe Joseph Smith was a prophet of God. I want to testify to you, Mr. Pollard, that I *know* Joseph Smith was a prophet of God, that by inspiration he translated the sacred record known as the Book of Mormon, that he did see God the Father

and Jesus the Son.’ The missionaries then departed the doorstep.

“[Mr. Pollard later testified:] ‘That evening, sleep would not come. I tossed and turned. Over and over in my mind I heard the words, “Joseph Smith was a prophet of God. I know it. . . . I know it. . . . I know it.” I could scarcely wait for morning to come. I telephoned the missionaries, using their number which was printed on the small card containing the Articles of Faith. They returned, and this time my wife, my family, and I joined in the discussion as earnest seekers of truth. As a result, we have all embraced the gospel of Jesus Christ’ ” (“The Prophet Joseph Smith,” 69).



If you have not done so, read Joseph Smith—History on your own and ask Heavenly Father to help you know that Joseph Smith’s account of the First Vision is true or to deepen your conviction that it is true. You may also want to look for opportunities to share the message of the First Vision with someone else.

 **5. Write your feelings about or testimony of the Prophet Joseph Smith in your scripture study journal.**

### **Scripture Mastery— Joseph Smith—History 1:15–20**

Take time to try and memorize this scripture mastery passage. If you feel like you cannot memorize all of the verses, you may want to divide the passage into smaller parts or memorize verses 16–17 or an abbreviated portion of the verses only. Here is one method to help you memorize these verses: Repeat a phrase until you can say it memorized. Add a second phrase, and repeat the phrases until you can recite them both. Add a third phrase, and so on. Speed up as you recite the phrases you have already learned, and slow down as you recite new ones.

 **6. Write the following at the bottom of today’s assignments in your scripture study journal:**

*I have studied Joseph Smith—History 1:1–20 and completed this lesson on (date).*

*Additional questions, thoughts, and insights I would like to share with my teacher:*

## UNIT 2: DAY 2

# Joseph Smith— History 1:21–26

### Introduction

After Joseph Smith received the First Vision in 1820, he shared his experience with a preacher who rejected his testimony. Others in the community also shunned and persecuted young Joseph. Men of great social standing went out of their way to publicly criticize him. In spite of this opposition, Joseph Smith remained true to his testimony.

### Joseph Smith—History 1:21–23

#### *Persecution against Joseph Smith increases*



President Gordon B. Hinckley shared an experience he had as a young missionary serving in London, England. As you read his account, ponder what you might do if you were in the position of this young man.

“[A young man came] to our apartment through the rain of the night. He knocked at the door, and I invited him in.

“He said, ‘I’ve got to talk with someone. I’m all alone. . . .’

“And I said, ‘What’s your problem?’

“And he said, ‘When I joined the Church a little less than a year ago, my father told me to get out of his home and never come back. And I’ve never been back.’

“He continued, ‘A few months later the cricket club of which I was a member read me off its list, barring me from membership with the boys with whom I had grown up and with whom I had been so close and friendly.’

“Then he said, ‘Last month my boss fired me because I was a member of this church, and I have been unable to get another job. . . .’

“‘And last night the girl with whom I have gone for a year and a half said she would never marry me because I’m a Mormon’ ” (“The Loneliness of Leadership” [Nov. 4, 1969], 3, speeches.byu.edu).

Have you ever felt that you were poorly treated or criticized because of your religious beliefs? What were your feelings at the time?

Although Joseph Smith was greatly blessed because he remained true to his testimony of the First Vision, he was also severely tested. As you study today, consider what you might learn from the way Joseph Smith responded to opposition to his testimony that can help you with the opposition you may face now or someday in the future.



In Joseph Smith—History, the Prophet described some of the opposition he faced because of his testimony. Read Joseph Smith—History 1:21–23, looking for words and phrases that help you understand what he experienced. According to verse 22, who was primarily involved in persecuting Joseph Smith? As you consider Joseph Smith’s age and circumstances in life, why do you think persecution from these people may have been especially difficult for him?

Notice the phrase near the end of Joseph Smith—History 1:20 that begins with the words “It seems as though. . . .” Beginning with these words, read the remainder of the verse, looking for why Joseph Smith experienced this persecution. According to Joseph, why did he experience great persecution at such a young age?

## Joseph Smith—History 1:24–26

*Although Joseph Smith is hated and persecuted, he remains true to his testimony*

Consider the many different accounts of faith and testimony in the scriptures. Is there another person in the scriptures whose character or strength of testimony you greatly admire?



1. Read Joseph Smith—History 1:24, and identify a person in the scriptures whom Joseph Smith admired and identified with because of the persecutions he faced. In your scripture study journal, answer the following questions:
  - a. How do you think it may have been helpful for Joseph Smith to see things he had in common with the Apostle Paul?
  - b. What lesson can we learn about how to deal with difficult challenges from Joseph Smith’s example of studying and pondering Paul’s experiences?

One lesson we can learn is that **during difficult times we can draw strength from the examples of faithful individuals in the scriptures.** (You may want to write this principle in the margins of your scriptures by Joseph Smith—History 1:24.)



2. In your scripture study journal, write about a time when you have been strengthened by studying the experience of a faithful individual in the scriptures.

In your study of the Doctrine and Covenants this year, you will encounter many individuals with whom you can identify and whose examples you can draw upon for the strength you need.

Ponder this phrase from the Prophet’s testimony in Joseph Smith—

History 1:25: “I had seen a vision; I knew it, and I knew that God knew it, and I could not deny it.”



3. In your scripture study journal, answer one or both of the following questions:
  - a. What does the phrase in Joseph Smith—History 1:25 teach you about Joseph Smith’s testimony of the First Vision?
  - b. How can you strengthen your witness of the First Vision?



4. Review Joseph Smith—History 1:24, and then study verse 25, looking for additional doctrines and principles

### Identifying Principles

A principle is an enduring truth or rule that we can adopt to guide us in making decisions. Identifying principles as you study the scriptures can help you apply the scriptures to your own life.



that can help you when you face opposition or feel tempted to waver in your testimony. Write these additional truths you discover in your scripture study journal.

 **5.** Select one of the truths you identified from Joseph Smith—History 1:24–25. In your scripture study journal, answer the following questions based on the truth you selected.

- a. How did the Prophet Joseph Smith illustrate this truth in his life?
- b. How might this truth be helpful to you?
- c. How would living this truth affect your choices, or how has living this truth already affected your life?

### Recording Doctrines and Principles

Learning how to identify gospel doctrines and principles found in the scriptures takes thoughtful effort and practice. Writing them in the margin of your scriptures or in your scripture study journal can help you recall them later.

Some additional doctrines and principles you might have identified in Joseph Smith—History 1:24–25 are: **The knowledge we receive from God is true even if the world rejects it. We should be more concerned about what God thinks of us than what men think. Even if we are hated and persecuted for our**

**testimonies, we must remain true to them.**

Think back to the story President Hinckley told about the young man in London, England, who faced great opposition because of his religious beliefs. President Hinckley continued his account:

“I said, ‘If this has cost you so much, why don’t you leave the Church and go back to your father’s home and to your cricket club and to the job that meant so much to you and to the girl you think you love?’

“He said nothing for what seemed to be a long time. Then, putting his head down in his hands, he sobbed and sobbed. Finally, he looked up through his tears and said, ‘I couldn’t do that. I know this is true, and if it were to cost me my life, I could never give it up.’

“He picked up his wet cap and walked to the door and out into the rain, alone and trembling and fearful, but resolute. As I watched him, I thought of the loneliness of conscience, the loneliness of testimony, the loneliness of faith, and the strength and comfort of the Spirit of God” (“The Loneliness of Leadership,” 3–4).

Choose one of the truths you listed, and set a goal to apply that truth in your life. (You may want to write this goal in your scripture study journal.)

To conclude, read Joseph Smith—History 1:26, and look for the following principle Joseph Smith demonstrated: **By acting on principles taught in the scriptures, we can gain a testimony of their truth.**

As you act on the doctrine or principle you have written about, your testimony will be strengthened and you will be able to prevail against the opposition or challenges you may face.

 **6.** Write the following at the bottom of today’s assignments in your scripture study journal:

*I have studied Joseph Smith—History 1:21–26 and completed this lesson on (date).*

*Additional questions, thoughts, and insights I would like to share with my teacher:*

## UNIT 2: DAY 3

# Joseph Smith— History 1:27–54; Doctrine and Covenants 2

### Introduction

Young Joseph Smith continued to affirm that he had seen a vision, and he continued to be persecuted for it. When he was 17 years old, one evening as Joseph was praying, an angel named Moroni appeared and declared that God had a work for Joseph to do, including the translation of an ancient record written on gold plates. While explaining Joseph’s role in the Restoration of the gospel, Moroni quoted a number of prophecies from the Bible, including Malachi’s prophecy about the return of Elijah. The next day, Joseph Smith went to the hill where Moroni had said the gold plates were buried. There he received further instruction from Moroni.

## Joseph Smith—History 1:27–29

### *Joseph Smith prays for forgiveness of his sins*

During today’s lesson you will learn more about young Joseph Smith. Read Joseph Smith—History 1:27–29, and liken these verses to yourself.

#### **Likening the Scriptures to Yourself**

To liken the scriptures is to compare them to your own life. You can ask, “How am I like the individuals I am studying in the scriptures?” As you see the similarities between your experiences and those of people in the scriptures, you are better able to identify doctrines and principles and receive revelation concerning how you can apply those truths in your own life.

Ponder the situations and feelings Joseph Smith experienced as a youth. How are they similar to those you face?

In Joseph Smith—History 1:28, Joseph wrote that while he was not guilty of any great sins, he did not always act as one who had been called of God should act. We can learn important lessons from what Joseph Smith did in response to what he did wrong.

Remember that Heavenly Father is willing to forgive us as we exercise faith in Jesus Christ and do what is necessary to repent of our sins.

## Joseph Smith—History 1:30–35

### *The angel Moroni appears to Joseph Smith*

While Joseph Smith was praying for forgiveness, the angel Moroni appeared to him. Read Joseph Smith—History 1:30–32, and try to visualize what this experience would have been like.

Read Joseph Smith—History 1:33, and find Moroni’s message to Joseph Smith. You may want to mark words or phrases that indicate that **God had a work for Joseph Smith to do**. Ponder what Joseph might have felt as he learned of what the Lord would do through him.

1. Review the end of Joseph Smith—History 1:28, and then write in your scripture study journal what Joseph Smith did in response to what he did wrong. In addition, list one or two principles you learn from Joseph’s example.

Some truths we can learn from Joseph Smith—History 1:28 are: **As we recognize our sins and feel sorrow for them, we can pray to Heavenly Father for forgiveness. We can pray to know of our standing before God.**

2. Answer the following question in your scripture study journal: How could praying to know of your standing before God help you?



Read the following instruction from Elder Neil L. Andersen of the Quorum of the Twelve Apostles to better understand how prayer can help us know of our standing before God and recognize changes He might have us make:

“How do we decide where our repentance should be focused? . . . [We can] humbly petition the Lord: ‘Father, what wouldst Thou have me do?’ The answers come. We feel the changes we need to make. The Lord tells us in our mind and in our heart.

“We then are allowed to choose: will we repent, or will we pull the shades down over our open window into heaven?” (“Repent . . . That I May Heal You,” *Ensign* or *Liahona*, Nov. 2009, 41).



3. Moroni prophesied that Joseph Smith’s name would be “both good and evil spoken of among all people” (Joseph Smith—History 1:33). In your scripture study journal, write about evidence you have witnessed that shows this prophecy is being fulfilled.

Moroni also taught Joseph Smith about the work he would perform. Read Joseph Smith—History 1:34–35, and identify what that work would be.

## Joseph Smith—History 1:36–49; Doctrine and Covenants 2

### Moroni instructs and warns Joseph Smith

In Joseph Smith—History 1:36–42 we read that Moroni quoted many prophecies from the Bible to explain that the Restoration of the gospel was about to commence. As you read these verses, you may want to mark the references to the scripture passages that are mentioned.

Read Joseph Smith—History 1:38–39. In 1876 Brigham Young directed that Moroni’s words in these verses be added to the Doctrine and Covenants as section 2. This prophecy of Elijah’s return was one of the earliest revelations given in this dispensation, and it is of such importance that it also appears in the Old Testament (Malachi 4:5–6), New Testament (Luke 1:17), and Book of Mormon (3 Nephi 25:5–6). You may want to write these cross-references next to Joseph Smith—History 1:38–39 and Doctrine and Covenants 2.



President Henry B. Eyring of the First Presidency said the following about Elijah and the priesthood power he would restore: “It is important to know why the Lord promised to send Elijah. Elijah was a great prophet with great power given him

by God. He held the greatest power God gives to His children: he held the sealing power, the power to bind on earth and have it bound in heaven” (“Hearts Bound Together,” *Ensign*, May 2005, 78).

Using President Eyring’s explanation to help you, summarize the meaning of Doctrine and Covenants 2:1 in your own words: \_\_\_\_\_

Doctrine and Covenants 2:2 refers to promises made to the fathers. Elder Bruce R. McConkie of the Quorum of the Twelve Apostles clarified who these fathers are and what promises were made to them: “Who are the fathers? They are Abraham, Isaac, and Jacob, to whom the promises were made. What are the promises? They are the promises of a continuation of the family unit in eternity” (*The Millennial Messiah: The Second Coming of the Son of Man* [1982], 267).

In addition to referring to the Old Testament prophets Abraham, Isaac, and Jacob, “the fathers” refers to others, as President Joseph Fielding Smith explained: “The fathers are our dead ancestors who died without the privilege of receiving the gospel, but who received the promise that the time would come when that privilege would be granted them. The children are those now living who are preparing genealogical

data and who are performing the vicarious ordinances in the temples” (*Doctrines of Salvation*, ed. Bruce R. McConkie, 3 vols. [1954–56], 2:127).

Using the explanations given above, summarize the meaning of Doctrine and Covenants 2:2 in your own words: \_\_\_\_\_

Doctrine and Covenants 2:3 states that the earth would be utterly wasted if Elijah did not come. President Joseph Fielding Smith explained why this would occur: “Why would the earth be wasted? Simply because if there is not a welding link between the fathers and the children—which is the work for the dead—then we will all stand rejected; the whole work of God will fail and be utterly wasted” (*Doctrines of Salvation*, 2:122; see also D&C 128:17–18).

Using this explanation, summarize the meaning of Doctrine and Covenants 2:3 in your own words: \_\_\_\_\_

The following are some examples of truths you may have identified in Doctrine and Covenants 2:1–3. Match the truth with the appropriate verse where it is taught.

___ 1. <b>God would send Elijah to restore the sealing power to the earth before the Second Coming of Jesus Christ.</b>	a. D&C 2:1
___ 2. <b>Our hearts can be turned to our family members, and we can perform ordinances that unite us with them eternally.</b>	b. D&C 2:2
___ 3. <b>If families are not united through the sealing power, the earth would be wasted at Jesus Christ’s Second Coming.</b>	c. D&C 2:3

 **4. Based on what you have learned from Doctrine and Covenants 2, record in your scripture study journal a few sentences explaining your feelings about the importance of Elijah’s return.**

In your study of Doctrine and Covenants 110 later this year, you will learn how this prophecy was fulfilled as Elijah returned and bestowed the sealing power upon the Prophet Joseph Smith.



# Joseph Smith— History 1:55–65

After Moroni taught Joseph Smith about the return of Elijah, quoted other prophecies of the Restoration, and provided further instructions about the gold plates, he departed (see Joseph Smith—History 1:42–43). Read Joseph Smith—History 1:44–45, and identify what happened following Moroni’s departure.

Read Joseph Smith—History 1:46–49, and look for the number of times Moroni repeated his message to Joseph Smith. In total, how many times did Moroni deliver his message to Joseph Smith?

One truth we learn from this is that **the Lord and His servants often repeat important teachings.**

Consider the sacrament prayers. Why are they repeated each week word for word? Think about teachings that you have heard repeated in the scriptures and during general conferences.

 **5.** In your scripture study journal, list some examples of teachings you have heard repeated, and then explain why you think the Lord and his servants often repeat teachings. Be sure to describe how you might apply this truth this year.

## Joseph Smith—History 1:50–54

*Joseph goes to the hill and uncovers the record, the Urim and Thummim, and the breastplate*

Joseph Smith—History 1:50–51 explains that after he told his father about the visits from Moroni, Joseph went to the hill where the gold plates were buried.

 **6.** Imagine how you would feel if you were Moroni and were visiting with Joseph Smith after waiting more than 1,400 years for the plates to be uncovered and translated. As you imagine this, read Joseph Smith—History 1:52–54, and then write in your scripture study journal about how you might have felt during this experience.

In the next lesson you will discover what occurred at the end of the four-year waiting period.

 **7.** Write the following at the bottom of today’s assignments in your scripture study journal:

*I have studied Joseph Smith—History 1:27–54 and Doctrine and Covenants 2 and completed this lesson on (date).*

*Additional questions, thoughts, and insights I would like to share with my teacher:*

## Introduction

After four years of receiving instructions from the angel Moroni, Joseph Smith was given charge of the gold plates, and he began to translate the Book of Mormon. Martin Harris was allowed to show some of the characters copied from the plates and their translation to scholars in New York. Notice how Joseph Smith took his charge concerning the plates seriously.

## Joseph Smith—History 1:55–58

*Joseph experiences significant events in early adulthood*

Think about significant events that have happened in the lives of teenagers you know. (These might include patriarchal blessings, jobs, education, family situations changing, or even deaths of loved ones.) What is a significant event that has happened to you in the past few years? How do you feel this event has affected your character and your future?

Read Joseph Smith—History 1:55–58, and identify important events in Joseph Smith’s life that occurred before he received the gold plates from the angel Moroni.

It is important to know that during this time Joseph’s older brother Alvin died. This event played a role in future revelations that you will learn about later in the year (see D&C 137:1–6).

Another important event during this time was his marriage to Emma Hale. The Prophet’s mother, Lucy Mack Smith, remarked about her son’s marriage to Emma: “We were pleased with his choice and not only consented to his marrying her, but requested him to bring her home with him and live with us” (*History of Joseph Smith by His Mother*, ed. Preston Nibley [1958], 93).

## Joseph Smith—History 1:59–62

### *Joseph receives the plates and begins translating*

Imagine that your father entrusted you with a copy of the first edition of the Book of Mormon (which is worth nearly \$180,000 in today's currency). How would you treat that book if you understood its monetary value? How would you treat it if you found out it was the last original copy of the Book of Mormon in existence?

Joseph Smith was entrusted with something very significant. Ponder what you can learn from his example as you study his account. Read Joseph Smith—History 1:59, and look for the significant items the angel Moroni entrusted to Joseph (consider marking these items in your scriptures).

What responsibility did Joseph receive concerning these items? Complete the following principle based on what Moroni promised Joseph, as recorded in Joseph Smith—History 1:59: **As I take responsibility for and preserve that which the Lord has given me, He will \_\_\_\_\_**

One way you could complete the principle is “provide His protection and help.”

Read Joseph Smith—History 1:60, and look for what occurred as Joseph took possession of the gold plates.



As you read, notice how the Lord fulfilled His promise as Joseph was faithful to the responsibility he had been given.

After Joseph Smith received the plates from Moroni, he initially hid them in a decayed birch log about three miles from his home. To understand how the Lord provided His protection and help as Joseph Smith used all his power to be responsible for the gold plates, read the following description from Joseph Smith's mother about what occurred shortly after he obtained the plates at the Hill Cumorah from Moroni:

“Joseph, on coming to them, took them from their secret place, and, wrapping them in his linen frock, placed them under his arm and started for home.

“After proceeding a short distance, he thought it would be more safe to leave the road and go through the woods. Traveling some distance after he left the road, he came to a large windfall, and as he was jumping over a log, a man sprang up from behind it and gave him a heavy blow with a gun. Joseph turned around and knocked him down, then ran at the top of his speed. About half a mile farther he was attacked again in the same manner as before; he knocked this man down in like manner as the former and ran on again; and before he reached home he was assaulted the third time. In striking the last one, he dislocated his thumb, which, however, he did not notice until he came within sight of the house, when he threw himself down in the corner of the fence in order to recover his breath. As soon as he was able, he arose and came to the house. He was still altogether speechless from fright and the fatigue of running” (*History of Joseph Smith by His Mother*, 108).



Although protecting the gold plates was never easy for Joseph Smith, notice how God blessed and strengthened him to be able to fulfill his responsibility. Elder D. Todd Christofferson of the Quorum of the Twelve Apostles gave some counsel about the sacred trusts the Lord has given you:

“Be wise with what the Lord gives you. It is a trust. . . .

“Rather than letting your life drift into carelessness, may it be one of increasing exactness in obedience. I hope you will think and feel and dress and act in ways that show reverence and respect for sacred things, sacred places, sacred occasions” (“A Sense of the Sacred,” *New Era*, June 2006, 31).

Think about some of the sacred trusts that Heavenly Father has given us, such as treating our bodies with reverence, baptismal and temple covenants, priesthood authority and duties, Church callings, the responsibility

to nourish our minds and spirits, family responsibilities and relationships, and the admonition to share the gospel. Evaluate whether you are currently being careless and neglectful or responsible for those things entrusted to you. Ponder what blessings may come to you as you strive to treat all of your sacred trusts with greater care.

 **1.** In your scripture study journal, record some of the sacred trusts you feel you have been given and the blessings that may come to you as you treat those trusts with care.

To see how the Lord continually blessed Joseph and Emma Smith for their faithfulness, read Joseph Smith—History 1:61–62. By what means did the Lord bless the Prophet and his wife at this time?

### Joseph Smith—History 1:63–65

#### *Martin Harris presents characters from the plates to scholars in New York*

Imagine that you were allowed to copy some of the actual characters from the gold plates. What would you do with the copy? What would you do if you wanted to prove to a friend that the gold plates really were of ancient origin, just as you had been saying all along?



The preceding picture is an example of characters that were written on the gold plates. In 1827, Joseph Smith copied some of the characters onto a piece of paper. Martin Harris asked if he could show the characters to scholars who had some knowledge of ancient languages and civilizations. Martin may have felt that the scholars' certification of the characters would help his wife, who did not approve of Martin helping Joseph Smith in the process of translation. Martin Harris may also have hoped a certification of the authenticity of the characters could help him raise money to pay for the publication of the Book of Mormon. We do not know if the copy depicted here is the same as the one Martin Harris presented to the scholars because several copies of the characters were made.

 **2.** Copy the following chart in your scripture study journal:

Joseph Smith—History 1:63–65	Isaiah 29:10–12

Joseph Smith—History 1:63–65 gives the account of Martin Harris meeting with the scholars. This event was prophesied by the ancient prophet Isaiah. Read that scripture passage; then read Isaiah 29:10–12. (It will be helpful to read the chapter heading to Isaiah 29 as well.) As you read these passages, summarize what is being said in the corresponding column in your chart. When you have completed both sides of the chart, look for similarities between Martin Harris's account and Isaiah's prophecy and record what you find in your scripture study journal.

What truth does Isaiah's prophecy and the account of Martin Harris showing the characters to the scholars teach us about God's foreknowledge and the prophecies of the Lord's servants?



You may desire to write the following statement of truth in your scriptures next to this account in Joseph Smith—History 1:63–65: ***The prophecies of the Lord's servants will come to pass.*** Can you think of a scripture mastery passage that teaches this same truth?

---



---



### Be Familiar with and Review Scripture Mastery from Other Years

Periodically take some time to become familiar with and review scripture mastery references from previous years or future years. This will increase your ability to remember them and use them in a variety of settings. Lists of the scripture mastery references can be found in the seminary materials on [si.lds.org](http://si.lds.org) and on scripture mastery bookmarks.

Two scripture mastery passages that teach that the prophecies of the Lord's servants will come to pass are Doctrine and Covenants 1:37–38 and Amos 3:7. You may want to write these references next to Joseph Smith—History 1:65 in your scriptures.

After Martin Harris showed the characters to Professor Anthon and Dr. Mitchell, he returned to Palmyra with renewed determination to assist in the publication of the Book of Mormon.

Harmony, where Emma's family lived, thus helping to support Joseph while he translated the plates. In February 1828, Joseph allowed Martin to take copies of characters from the plates to be authenticated by two professors in New York City (see Joseph Smith—History 1:63–65). Lucy Harris, Martin's wife, had become increasingly concerned about Martin's interest and financial involvement in the translation of the plates. She and others began to pressure Martin for evidence of the plates' existence. To satisfy their concerns, in mid-June Martin requested that Joseph allow him to take the 116 pages of manuscript they had completed to show as evidence.

### Doctrine and Covenants 3:1–3

*Joseph Smith learns that the work of God cannot be frustrated*

Think of situations when you might be tempted to listen to a friend rather than follow the counsel or commandments of Heavenly Father. For instance, you might be tempted to allow a friend to copy your homework or be tempted to watch an inappropriate movie or video on the Internet with your friends. Why is it sometimes difficult to resist friends when they ask you to do something you know is wrong?

By mid-June 1828, the Prophet Joseph Smith, with Martin Harris as scribe, had translated 116 pages of manuscript from the gold plates. Martin asked Joseph to allow him to take the manuscript to "read to his friends that [perhaps] he might convince them of the truth" (*Histories, Volume 1: Joseph Smith Histories, 1832–1844*, vol. 1 of the Histories series of *The Joseph Smith Papers* [2012], 15). Joseph approached the Lord with Martin's request but was told not to let the manuscript out of his possession. Martin convinced Joseph to ask again—which resulted in a second refusal from the Lord. Martin prevailed upon Joseph to ask once more and, on this third request, the Lord gave permission for Martin to take the manuscript if he agreed to show the manuscript only to his wife and a few select family members. However, Martin broke his oath and the manuscript was lost. Because Joseph had not accepted the Lord's initial counsel but delivered "that which was sacred into the hands of a wicked man" (D&C 3:12), Moroni took the plates and the Urim and Thummim from the Prophet. However, Joseph was told that he could receive them again if he would be "humble and penitent" (Lucy Mack Smith, *History of Joseph Smith by His Mother*, ed. Preston Nibley [1958], 134).

 **3.** In your scripture study journal, write a few sentences summarizing what you learned in today's lesson and why it is important to you. Consider sharing what you wrote with your family or a friend.

 **4.** Write the following at the bottom of today's assignments in your scripture study journal:

*I have studied Joseph Smith—History 1:55–65 and completed this lesson on (date).*

*Additional questions, thoughts, and insights I would like to share with my teacher:*

## UNIT 3: DAY 1

# Doctrine and Covenants 3; 10

### Introduction

From mid-April to mid-June 1828, the Prophet Joseph Smith was translating the gold plates while living in Harmony, Pennsylvania. A wealthy farmer and businessman named Martin Harris was acting as scribe while Joseph translated the Book of Mormon. Martin was 22 years older than Joseph and had given Joseph and Emma \$50 (which was a substantial amount of money at that time) to relocate to

Considering what you know about Martin Harris and all that he had done for Joseph Smith, why do you think Joseph persisted in asking God if Martin could take the manuscript even though God had already given a clear answer the first two times he asked?



After the loss of the 116 pages, the Prophet experienced great anguish of soul. In July 1828, Moroni temporarily returned the Urim and Thummim to Joseph for the purpose of receiving the revelation found in Doctrine and Covenants 3. Read Doctrine and Covenants 3:1–3, and mark a truth God revealed to the Prophet Joseph Smith in those verses.

From these verses we learn that **the purposes of God cannot be frustrated**. It may help you to understand that, as used in Doctrine and Covenants 3:1, the word *frustrated* means prevented from being accomplished.

-  **1.** In your scripture study journal, write how this truth could have been comforting to Joseph Smith at that time. Why do you think it is important for those engaged in the Lord's service to also understand that God's purposes cannot be frustrated?

## Doctrine and Covenants 3:4–15

*The Lord rebukes Joseph Smith and exhorts him to repent*

Although the Lord reassured Joseph, He also wanted His young prophet to understand the mistakes he had made and the consequences of those mistakes. Read Doctrine and Covenants 3:4–6, and identify words and phrases that might have been hard for Joseph Smith to hear.

Now read Doctrine and Covenants 3:12–15, and look for why Joseph's actions were so serious in the eyes of the Lord. It may be helpful to understand what is meant by the Lord referring to Martin Harris as a "wicked man" (D&C 3:12). Martin was not a man who enjoyed sin and was unrepentant or immoral. Rather, he was a man who sinned by yielding to weakness within himself, including pride. In Doctrine and Covenants 3:13, notice the reasons the Lord gave explaining how Martin was wicked.

The Lord reminded Joseph what he should have done when he was under pressure from Martin Harris. Read Doctrine and Covenants 3:7, and complete the

following truth based on the Lord's counsel to Joseph Smith: **We should fear God more than \_\_\_\_\_**. You may want to mark the words or phrases in verse 7 that teach this principle.

The following explanation from Elder D. Todd Christofferson of the Quorum of the Twelve Apostles can help you better understand this truth:



"There are many places in the scriptures that counsel mankind to fear God. In our day we generally interpret the word *fear* as 'respect' or 'reverence' or 'love'; that is, the fear of God means the love of God or respect for Him and His law.

That may often be a correct reading, but I wonder if sometimes *fear* doesn't really mean *fear*, as when the prophets speak of fearing to offend God by breaking His commandments. . . .

". . . We should so love and reverence Him that we fear doing anything wrong in His sight, whatever may be the opinions of or pressure from others" ("A Sense of the Sacred" [Church Educational System fireside for young adults, Nov. 7, 2004], 6–7).

-  **2.** In your scripture study journal, explain how fearing, meaning loving and reverencing and fearing to offend God, as Elder Christofferson explained, can help us make right decisions even when we feel pressure from others.

Joseph Smith was told what God would have done if Joseph had listened to His first answer to Martin Harris's request. Mark this reassurance in Doctrine and Covenants 3:8.

-  **3.** From what you learn in Doctrine and Covenants 3:8, complete this "if-then" principle in your scripture study journal: ***If we are faithful to the Lord's commandments, then . . .***

Think about a time or times when you chose to follow the Lord's commandments rather than the persuasions or influence of other people. In what ways have you seen this promise fulfilled in your life?

-  **4.** At the beginning of this lesson you were asked to think about situations when you might be tempted to listen to a friend instead of being obedient to Heavenly Father. In your scripture study journal, explain how the truth you learned in Doctrine and Covenants 3:8 might help you when you are tempted or feel pressure to do something you know is not right.

Read Doctrine and Covenants 3:9–11, and look for the promise the Lord gave to Joseph Smith despite the seriousness of the mistakes he had made. Think about how this promise applies to us when we sin or make mistakes.



## Doctrine and Covenants 3:16–20

*The Lord explains His purposes for the Book of Mormon*

In Doctrine and Covenants 3:16–20 the Lord’s purposes for the Book of Mormon are explained. Read these verses, and find why the work Joseph Smith was doing was so important to the Lord and His people.

## Doctrine and Covenants 10:1–4

*The Lord restores Joseph’s gift to translate*

Some time after the Book of Mormon plates and the Urim and Thummim were returned to him, the Prophet Joseph Smith received direction from the Lord about what to do about the portion of the plates corresponding to the manuscript pages that were lost. The Lord commanded Joseph not to retranslate that portion, and He revealed Satan’s plot to destroy the work of God. He then commanded Joseph to translate the small plates of Nephi that would be used to replace the material from the 116 pages that were lost and explained the purpose of the Book of Mormon and its role in establishing His Church.

In Doctrine and Covenants 10:1–2 the Lord reminded Joseph why the power to translate was taken from him and what happened as a result of his mistake. Read Doctrine and Covenants 10:3–4, and look for counsel the Lord gave to Joseph Smith as he began to translate again.

How might Joseph’s remorse regarding the loss of the manuscript have affected his desire to work harder in his translation efforts? The Lord knew that Joseph Smith had other priorities in life, such as caring for his wife and earning a living, and counseled him not to labor or to translate more than he had strength. How might the counsel to not run faster than you have strength guide you?

## Doctrine and Covenants 10:5–37

*Satan seeks to destroy Joseph Smith and the work of God*

How could a snare or a trap like the one pictured represent Satan’s intentions toward us?

Read Doctrine and Covenants 10:5, and look for what the Lord commanded the Prophet Joseph Smith to do in order to escape Satan’s traps. (Doctrine and Covenants 10:5 is a scripture mastery passage.)

Complete the following principle based on what Doctrine and Covenants 10:5 teaches about the blessings that can come from prayer: **As we pray always,** \_\_\_\_\_.

You may want to mark the words and phrases in Doctrine and Covenants 10:5 that teach this principle.



The Lord warned Joseph of a trap Satan had set to destroy the Prophet and the work of God. Read Doctrine and Covenants 10:6, 10–19, and identify the plan of the wicked individuals who were then in possession of the manuscript that Martin Harris had taken home.

In Doctrine and Covenants 10:20–29 the Lord spoke about Satan’s influence on the people who stole the 116 pages of manuscript. He also revealed Satan’s purposes. From these verses we learn that **Satan desires to destroy the work of the Lord and our souls.**

 **5.** How can being aware of Satan’s intentions and methods help you avoid and escape his traps? In your scripture study journal, write a plan of what you can do to avoid or escape his traps, such as avoiding viewing immoral images if they suddenly appeared before you or going places you know you should avoid.

In Doctrine and Covenants 10:30–37 we learn that because of those wicked people’s plan to destroy the work of God and Joseph Smith’s reputation, the Lord commanded the Prophet not to retranslate the portion of the plates that was on the lost pages.

## Doctrine and Covenants 10:38–45

*The Lord commands Joseph Smith to translate the plates of Nephi*

Read Doctrine and Covenants 10:38–42, and look for what the Lord told the Prophet Joseph Smith to translate instead of the portion of the plates that had been translated on the lost manuscript.

The lost document contained the translation of the book of Lehi, which was in Mormon’s abridgment of the large plates of Nephi (covering 600 B.C. to 130 B.C.). Nephi had been inspired to write the small plates of Nephi and Mormon had been inspired to include the small plates of Nephi with his record for “a wise

purpose,” which at the time they did not completely understand (see 1 Nephi 9:5; Words of Mormon 1:3–7). The small plates of Nephi covered approximately the same time period (from 600 B.C. to 130 B.C.) as the book of Lehi.

How does knowing that God prepared a way to compensate for the 116 lost manuscript pages thousands of years before they were lost help you more fully trust in Him?

## Doctrine and Covenants 10:46–70

*The Lord explains the purpose for the Book of Mormon and its role in establishing His Church*

In Doctrine and Covenants 10:46–70 we learn that the Lord answered the faithful prayers of His Nephite disciples by preserving and bringing forth the Book of Mormon in our day. The Lord taught the Prophet Joseph Smith that the Book of Mormon “bring[s] to light the true points of [His] doctrine” (D&C 10:62). Building upon those points of doctrine, the Savior established His Church in the last days.

### Scripture Mastery—Doctrine and Covenants 10:5

 **6.** Reread Doctrine and Covenants 10:5, and then write in your scripture study journal about a time when prayer has helped you to gain victory over Satan.

 **7.** Write the following at the bottom of today’s assignments in your scripture study journal:

*I have studied Doctrine and Covenants 3; 10 and completed this lesson on (date).*

*Additional questions, thoughts, and insights I would like to share with my teacher:*

## UNIT 3: DAY 2

# Doctrine and Covenants 4

## Introduction

In February 1829, Joseph Smith Sr. and his wife, Lucy, visited their son Joseph Smith Jr. in Harmony, Pennsylvania. Joseph Smith Sr. desired to know what the Lord wanted him to do to assist in the work of the Restoration. During that visit Joseph Smith Jr. received

a revelation. This revelation, addressed to the Prophet’s father, is the first in a series of several revelations given to individuals who desired to assist the Lord in His work (see also D&C 6; 8–9; 11–12; 14–16; 23; 25).

## Doctrine and Covenants 4:1–3

*Joseph Smith Sr. is called to labor in God’s service*



Have you ever desired to serve God and wanted to know His will regarding how you could best assist in doing His work? Joseph Smith’s father desired to assist the Lord in His work, but he didn’t know what the Lord wanted Him to do. He asked his son, the Prophet, to inquire of the Lord on his behalf.

Doctrine and Covenants 4 is the Lord’s response. In this revelation He outlined the qualities He expects of those who desire to assist Him in His work. Notice as you read this section what the Lord taught Joseph Smith Sr. about how we are to serve Him.

When this revelation was received, the Church had not yet been organized, the translation of the Book of Mormon had not been completed, and the priesthood had not yet been restored. Read Doctrine and Covenants 4:1, looking for how the Lord described the Restoration of the gospel that was just beginning to unfold. You may want to mark the word the Lord used to describe the Restoration of the gospel in the latter days. In what ways was the Restoration of the gospel “marvelous”?

Read Doctrine and Covenants 4:2, and look for what the Lord asks of those who embark, or begin, in His service. Finish the following principle based on Doctrine and Covenants 4:2: **If we serve God with all of our heart, might, mind, and strength, we can**

You may also want to mark words or phrases that teach this principle in Doctrine and Covenants 4:2.

 **1.** Answer the following questions in your scripture study journal:

- What do you think it means to do something “with all your heart, might, mind and strength”?
- How could understanding and applying this principle help you as you participate in the work of the Lord?

Read Doctrine and Covenants 4:3, and look for what we need to have that will help us succeed in assisting with God’s work. You may want to mark what you find.

Some consider Doctrine and Covenants 4 primarily as a call to full-time missionary service. However, Joseph Smith Sr., to whom this revelation was given, was not being called as a full-time missionary. He did, however, follow the counsel in Doctrine and Covenants 4:2–3 for the rest of his life, serving with commitment wherever and whenever he was called. He was one of the Eight Witnesses of the Book of Mormon and one of the first to be baptized when the Church was officially organized on April 6, 1830. He also served as the first Patriarch to the Church and as Assistant Counselor to the First Presidency. Think of some other ways, in addition to full-time missionary service, you can assist the Lord in His work. For example, the following excerpt from the *For the Strength of Youth* booklet on the topic of service gives some ideas about how you can act on your desire to assist in the Lord’s work now:

“Service to others is an important characteristic of a disciple of Jesus Christ. A disciple is willing to bear other people’s burdens and to comfort those who need comfort. Often Heavenly Father will meet the needs of others through you.



“There are many ways to serve others. Some of the most important service you can give will be within your own home. You can also serve in your Church assignments, school, and community. You can serve by doing temple and family history work. You can serve by sharing the gospel with others now and as a full-time missionary in the future. Often the most meaningful service is expressed through simple, everyday acts of kindness. Seek the guidance of the Holy Ghost each day to know whom to serve and how to help meet their needs. Follow the example of the Savior as you serve others” (*For the Strength of Youth* [booklet, 2011], 32).

 **2.** In your scripture study journal, describe a specific way you want to assist the Lord in His work at this time in your life.

## Doctrine and Covenants 4:4

### *The field is ready to harvest*

In Doctrine and Covenants 4:4 the Lord referred to the people of the world as a field of grain. Read Doctrine and Covenants 4:4, and mark what the Lord said about His field (or the people of the world). It might help you more fully understand this verse to know that grains such as wheat or barley change color as they grow. When grain is young, it is green, but as it matures it grows pale. When the grain is ready for harvesting, it is often described as “white.” A large curved knife called a sickle is used for harvesting the grain.

 **3.** Answer the following questions in your scripture study journal:

- What do you think the phrase “the field is white already to harvest” means?
- What do you think it means to thrust in your sickle with your might?
- What is the reward mentioned in Doctrine and Covenants 4:4 for those who thrust in their sickle with their might?

One truth we can learn from this verse about the effect of our work to serve the Lord is that **as we labor diligently to bring others unto Jesus Christ, we can also receive salvation for ourselves.**

 **4.** In your scripture study journal, write about a time when you felt closer to Heavenly Father and Jesus Christ as you worked to help others come to Them.





## Doctrine and Covenants 4:5–7

*The Lord outlines the qualifications and key attributes for those who serve Him*

Think of two or three jobs, careers, or professions. What qualifications and necessary attributes would someone need to succeed in each of them?

Find a recipe for one of your favorite meals, and read the list of ingredients on it. What would happen if you tried to make that meal but did not include one or two of the ingredients? Doctrine and Covenants 4:5–6 contains a list of “ingredients” or attributes that qualify a person to assist in the Lord’s work. Read the verses, and consider marking each divine attribute listed. You may also want to mark words or phrases that teach this principle: **As we strive to develop divine attributes, it will help us qualify to assist in the work of the Lord.**

Consider how developing each of these divine attributes can help you better assist the Lord in His work.

 **5.** Choose one attribute from Doctrine and Covenants 4:5–6 that you would like to develop more fully. Using resources available to you (such as the Topical Guide or Guide to the Scriptures), find three other scriptures that teach about that attribute. (You may also want to read the *True to the Faith* entry or the entry in the Guide to the Scriptures for the attribute you

have chosen.) Write a brief summary in your scripture study journal of what you learned about that attribute, as well as what you can do now to begin developing that attribute. You may wish to share your plan with a parent or close friend.

Read Doctrine and Covenants 4:7, and look for how you can seek after and develop these attributes. Ponder on what it means to “ask” and to “knock.” How might prayer help us develop divine attributes?

 **6.** Write the following at the bottom of today’s assignments in your scripture study journal:

*I have studied Doctrine and Covenants 4 and completed this lesson on (date).*

*Additional questions, thoughts, and insights I would like to share with my teacher:*

## UNIT 3: DAY 3

# Doctrine and Covenants 5

## Introduction

Although Martin Harris lost the first 116 manuscript pages of the Book of Mormon during the summer of 1828, he maintained a desire to assist in the coming forth of the Book of Mormon. In March 1829, Martin planned to travel from his home in New York to visit Joseph and Emma Smith in Harmony, Pennsylvania. However, Martin’s wife, Lucy Harris, was upset about the time and money her husband was dedicating to the publication of the Book of Mormon. She was also angry with Joseph Smith for having denied her earlier requests to see the gold plates. She filed a legal complaint against Joseph and gathered a number of people who were willing to testify that he had lied about the existence of the plates. In addition to the threat of the lawsuit against Joseph, these people warned Martin Harris that if he did not join them in testifying of Joseph Smith’s alleged deception and fraud, Martin would also be guilty and would join Joseph in prison.

At this time Martin had never seen the gold plates himself, although he had acted as a scribe for Joseph. After traveling to Joseph’s home, Martin expressed his desire to receive a further witness of the reality of the gold plates. After Joseph listened to Martin’s request to see the plates, he inquired of the Lord and received the revelation in Doctrine and Covenants 5. In this

revelation the Lord declared that three witnesses would be called to testify of the Book of Mormon and informed Martin of what he must do to qualify to become one of these witnesses.

## Doctrine and Covenants 5:1–22

*The Lord declares He will bring forth His word in the last days and witnesses will testify*

Have you ever been asked to be a witness? What does it take to become an expert witness? Is there some event in world history that you would like to have witnessed personally? Is there any event in Church history that you would like to have seen or witnessed? Why?

In the introduction to this lesson you learned that Martin Harris desired to see the gold plates. Have you ever felt a desire to see the gold plates? Why?

Read Doctrine and Covenants 5:1–3, and look for how the Lord told Joseph Smith to answer Martin Harris’s request. According to these verses, why couldn’t Joseph Smith show Martin Harris the plates?

---

---

---

Have you ever wondered why the Lord has not allowed the gold plates to be displayed before the world? President Joseph Fielding Smith explained at



least one reason why people would desire to see the plates: “Frequently when [people] . . . hear the story of the coming forth of the Book of Mormon, they ask if the plates are in some museum where they may be seen. Some

of them with some scientific training [suggest] that if the scholars could see and examine the plates and learn to read them, they would then bear witness to the truth of the Book of Mormon and the veracity of Joseph Smith, and the whole world would then be converted” (*Church History and Modern Revelation*, 2 vols. [1953], 1:40).

As you read Doctrine and Covenants 5:5–10, look for why the Lord told Joseph Smith not to display the plates before the world.

According to Doctrine and Covenants 5:7, those who did not believe the Lord’s words revealed through Joseph Smith would not believe even if they were to see the plates.

 **1.** Based on what you have learned from Doctrine and Covenants 5:5–10, write a couple of sentences in your scripture study journal about why the Lord did not want Joseph Smith to display the plates before the world.

From Doctrine and Covenants 5:10 we learn that **the Lord called Joseph Smith to deliver His word to the world.** This was a calling unique to the Prophet Joseph Smith. You may want to mark the words that teach this truth in Doctrine and Covenants 5:10.

 **2.** Write in your scripture study journal why you think it is important to have a testimony of this truth.

Before this revelation was received, Martin Harris was called before a judge in New York to testify concerning the charges of deception and fraud against Joseph Smith. Martin boldly testified of Joseph Smith’s honesty and character and told the court: “As to the plates which he professes to have, gentlemen, if you do not believe it, but continue to resist the truth, it will one day be the means of damning your souls” (in Lucy Mack Smith, *History of Joseph Smith by His Mother*, ed. Preston Nibley [1958], 146). After hearing Martin’s testimony, the judge dismissed the case against Joseph Smith.

Read Doctrine and Covenants 5:11, and look for what the Lord said He would do to support the Prophet Joseph Smith’s testimony of the Book of Mormon. From this verse we learn that the Lord declared that **the testimony of the Three Witnesses will stand as evidence of the truthfulness of the Book of Mormon.** Read Doctrine and Covenants 5:11–15, looking for what the Three Witnesses would hear, see, and be charged to do. As you read, you may want to mark what you discover.

 **3.** Write your thoughts about the following questions in your scripture study journal:

- a. How could the testimony of three additional witnesses of the Book of Mormon plates be helpful to someone who is not a member of the Church?
- b. How could this truth be helpful for someone who *is* a member of the Church?



In addition to directing Joseph Smith and the Three Witnesses to bear testimony, the Lord provided another means by which we can know of the truthfulness of the Book of Mormon. Read Doctrine and Covenants 5:16, and look for what the Lord promised those who believe in the Book of Mormon.

Based on what you read, complete the following truth: **If we will believe on the Lord's words,** \_\_\_\_\_

(You also may want to write the completed principle in your scriptures near verse 16.)



President Ezra Taft Benson spoke of our individual responsibility to gain and share a witness of the Book of Mormon: "We each need to get our own testimony of the Book of Mormon through the Holy Ghost. Then our testimony, coupled with the Book of Mormon, should be shared with others so that they, too, can know through the Holy Ghost of its truthfulness" ("The Book of Mormon and the Doctrine and Covenants," *Ensign*, May 1987, 84).

 **4.** Write one or both of the following in your scripture study journal:

- a. Your own testimony of the Book of Mormon
- b. What you can do to gain or strengthen your witness that the Book of Mormon is true

Read Doctrine and Covenants 5:21–22, replacing the name "Joseph" with your own name. Ponder how you can avoid yielding "to the persuasions of men."

What did the Lord promise that Joseph Smith would receive if he would be faithful, even if he was "slain"?

## Doctrine and Covenants 5:23–35

*Martin Harris may be called as one of the Three Witnesses if he repents*

What is necessary to make a lightbulb work?

In addition to electricity, we would need to put the lightbulb in a lamp, plug in the lamp, and then turn on the lamp. Just as there are several steps to lighting a lightbulb, Martin Harris learned that there would be several steps to receiving the witness of the plates he desired from the Lord.



Read Doctrine and Covenants 5:23–24, and identify the conditional promise the Lord gave to Martin Harris. As you read, look for the word *if* and identify the several steps or conditions that follow that word.

Complete the following statement based on what you read: *If* Martin Harris will \_\_\_\_\_ *then* the Lord will grant him a view of the plates as he desired. Through this promise, the Lord was offering Martin Harris the opportunity to be a witness of the Book of Mormon.

The promise that the Lord gave to Martin Harris in Doctrine and Covenants 5:24 also applies to us: **If we sincerely pray in humility and faith, then we can receive answers according to our righteous desires.**

Ponder what it means to pray in humility, faith, and sincerity. Think about when you have heard or offered a prayer that you felt was offered in this way. What made this prayer different from other prayers you have heard or offered?

Read Doctrine and Covenants 5:25–26, and look for what the Lord expected Martin Harris to do after he became a witness to the Book of Mormon. Then read Doctrine and Covenants 5:27–28, 32, and look for additional counsel and warnings that the Lord gave to Martin Harris.

 **5.** In your scripture study journal, answer the following questions:

- a. What did the Lord counsel and warn Martin Harris to do?
- b. What did the Lord say would happen to Martin Harris if he did not humble himself and "receive a witness" (D&C 5:32) from the Lord?
- c. How might we relate the counsel in Doctrine and Covenants 5:32 to ourselves?

 **6.** Write the following at the bottom of today's assignments in your scripture study journal:

*I have studied Doctrine and Covenants 5 and completed this lesson on (date).*

*Additional questions, thoughts, and insights I would like to share with my teacher:*

### Identifying Doctrines and Principles

Identifying gospel doctrines and principles in the scriptures takes thoughtful effort and practice. One way is to look for promises the Lord gave to individuals or groups of people in the scriptures, as well as the conditions that are required in order for those promises to be fulfilled; then rewrite those promises and conditions so they apply to you. Another way is to look for words and phrases such as "thus we see," "therefore," "wherefore," "behold," or "if . . . , then . . . ," which often introduce principles or statements of doctrine. As you learn how to identify doctrines and principles in the scriptures, you will be able to study the scriptures more effectively.

# Joseph Smith— History 1:66–67; Doctrine and Covenants 6–7

## Introduction

In the spring of 1829, the Prophet Joseph Smith felt a sense of urgency about the translation of the Book of Mormon. He had found his time to translate severely limited because of the need to work to support his family. Emma and Joseph’s brother Samuel helped by acting as scribes, but they could not do this full time. Joseph had been entrusted with the plates for more than a year and a half and, with the loss of the 116 manuscript pages, had only a few pages of translated material to show for it. Joseph prayed that the Lord would send someone who could assist him in the work of translation. In response to Joseph’s prayer, the Lord sent Oliver Cowdery to serve as a scribe.

The revelations in Doctrine and Covenants 6–7 were given shortly after Oliver Cowdery’s arrival. Doctrine and Covenants 6 contains counsel to Oliver concerning his role in the Lord’s work. Doctrine and Covenants 7 contains a translated version of some writings by John the Beloved, teaching that the Lord granted John’s desire to live and bring souls to Jesus Christ until the Second Coming.

## Joseph Smith—History 1:66–67; Doctrine and Covenants 6:1–9

### *Oliver Cowdery becomes a scribe to Joseph Smith*

Revelation from God is sometimes compared to light. If revelation from God or an answer to prayer is like light, compare the following descriptions and think about which best represents how it has felt when you have received revelation or answers to your prayers:

- The immediate light that comes when you turn on a lightbulb
- The gradual light that comes from a sunrise

Elder David A. Bednar of the Quorum of the Twelve Apostles used this analogy to teach about personal revelation:

“A light turned on in a dark room is like receiving a message from God quickly, completely, and all at once.



Many of us have experienced this pattern of revelation as we have been given answers to sincere prayers or been provided with needed direction or protection, according to God’s will and timing. Descriptions of such immediate and intense manifestations are found in the scriptures, recounted in Church history, and evidenced in our own lives. Indeed, these mighty miracles do occur. However, this pattern of revelation tends to be more rare than common.

“The gradual increase of light radiating from the rising sun is like receiving a message from God ‘line upon line, precept upon precept’ (2 Nephi 28:30). Most frequently, revelation comes in small increments over time and is granted according to our desire, worthiness, and preparation. Such communications from Heavenly Father gradually and gently ‘distil upon [our souls] as the dews from heaven’ (D&C 121:45). This pattern of revelation tends to be more common than rare” (“The Spirit of Revelation,” *Ensign* or *Liahona*, May 2011, 88).



**1.** Ponder times when the Lord has answered your prayers immediately and times when He has answered gradually. Write in your scripture study journal about one of your experiences.

As you study Doctrine and Covenants 6, look for truths that will help you recognize when God is giving you revelation.

Read Joseph Smith—History 1:66–67, and look for how Oliver Cowdery came to know about the Prophet Joseph Smith and the work that he was doing. Oliver traveled from Palmyra, New York, to meet Joseph in Harmony, Pennsylvania, more than 140 miles away (see Church history map 1, “Northeastern United States”).

Shortly after Oliver began acting as scribe for Joseph, Joseph received a revelation in which the Lord spoke to Oliver. This revelation addressed Oliver's desires and apparently answered questions he had prayed about but had not expressed to Joseph. Read Doctrine and Covenants 6:5–6, 8, and look for indications that the Lord knew Oliver's desires.



**2.** In your scripture study journal, answer the following question: What do Doctrine and Covenants 6:5–6, 8 and Oliver Cowdery's effort to journey 140 miles tell us about him?

*Note:* The Lord's words in Doctrine and Covenants 6:1–9 are repeated in Doctrine and Covenants 11, a revelation directed to Hyrum Smith, and will be further discussed in that lesson.

## Doctrine and Covenants 6:10–24

*The Lord assures Oliver Cowdery of the truthfulness of the work*

Ponder whether you have ever received an answer from God and then later experienced concerns or confusion regarding the answer.

In Doctrine and Covenants 6:10–13 we see that the Lord told Oliver Cowdery that Oliver had the gift of revelation. Read Doctrine and Covenants 6:14–17, 20, and mark what the Lord taught Oliver about receiving and recognizing revelation.



**3.** In your scripture study journal, write two or three truths you identified in Doctrine and Covenants 6:14–17, 20 that can help you understand how to receive or recognize revelation.

Compare what you wrote in your scripture study journal to some of the following truths that are contained in these verses:

**As we seek answers from Heavenly Father, He will give us instruction** (see D&C 6:14). "Instruction" can refer to ideas or understanding that comes to our minds as well as experiences that can lead us, prepare us, or help us reach the proper decision.

**The Lord will enlighten our minds through the Holy Ghost.** The phrase "enlighten thy mind" (D&C 6:15) means that through the Holy Ghost, the Lord will give us ideas and understanding. You may want to mark this phrase in your scriptures.

**God knows our thoughts and the intents of our hearts** (see D&C 6:16).

**When we have received revelation, we should treasure it up in our hearts.** To "treasure up" the Lord's words (D&C 6:20) means to value the Lord's

words—to study, ponder, and act on the things the Lord reveals and to trust the revelation we receive.

Read Doctrine and Covenants 6:21–24, and search for another way the Lord communicates with us.

Fill in the blank with what you found: **The Lord speaks \_\_\_\_\_ to our minds as a witness of truth.** You might want to mark the phrase that teaches this truth in Doctrine and Covenants 6:23.

Ponder the following question: How might we sometimes overlook or dismiss the Lord's answers to our prayers?

Elder Bednar expanded on the analogy of the sunrise to help clarify how communication from the Lord often comes:



"Sometimes the sun rises on a morning that is cloudy or foggy. Because of the overcast conditions, perceiving the light is more difficult, and identifying the precise moment when the sun rises over the horizon is not possible. . . .

"In a similar way, we many times receive revelation without recognizing precisely how or when we are receiving revelation" ("The Spirit of Revelation," 89).

It was not until after the revelation in Doctrine and Covenants 6 was received that Oliver Cowdery told the Prophet about "the night" that the Lord referred to in verse 22. Joseph Smith recorded, "After we had received this revelation, Oliver Cowdery stated to me that after he had gone to my father's to board, and after the family had communicated to him concerning my having obtained the plates, that one night after he had retired to bed he called upon the Lord to know if these things were so, and the Lord manifested to him that they were true, but he had kept the circumstance entirely secret, and had mentioned it to no one; so that after this revelation was given, he knew that the work was true, because no being living knew of the thing alluded to in the revelation, but God and himself" (in *History of the Church*, 1:35).



**4.** Think about times in your life when you have felt your mind enlightened or felt peaceful about something you were praying about. Write about an experience in your scripture study journal; then consider writing some of these memories down in your personal journal.

Consider how remembering these experiences and trusting in the personal revelation you have received in the past can help you in the future when you are in need of revelation or guidance.

## Doctrine and Covenants 6:25–37

*The Lord counsels Joseph and Oliver to translate and to not doubt or fear*

In Doctrine and Covenants 6:25–31 we learn that the Lord told Oliver Cowdery that if he desired, he could have the gift of translation. The Lord also called him to stand with the Prophet Joseph Smith and “bring to light this ministry” as a second witness of the Restoration. If you were Oliver, what feelings might you have had as you heard the responsibility the Lord was placing upon you?

Think about situations when you may have felt doubtful or fearful about something the Lord wanted you to do, such as when you were sitting on the stand in a Church meeting and waiting to give a talk, feeling prompted to share the gospel with a friend, or knowing you needed to apologize to a family member for something you did or said.

Read Doctrine and Covenants 6:32–37, and search for the counsel the Lord gave Joseph Smith and Oliver Cowdery concerning doubts and fears in doing the work they were called to do.

One principle we can learn from this counsel is that **as we look unto Jesus Christ, we can overcome doubt and fear.** (Doctrine and Covenants 6:36 is a scripture mastery passage.)

### Scripture Mastery—Doctrine and Covenants 6:36

 **5.** In your scripture study journal, write a short (less than one page) talk based on Doctrine and Covenants 6:36. You might describe practical ways to follow the counsel in this scripture mastery passage. You could use sources such as the Topical Guide or Guide to the Scriptures, *True to the Faith*, or even family members to help you write your talk. Include a personal example of the Savior helping you overcome doubt or fear. Ask your parents if you can share the talk you prepared during a family home evening.

## Doctrine and Covenants 7

*John the Beloved is promised that he will live and bring souls to Christ until the Second Coming*

Sometime during April 1829, while Oliver Cowdery was helping the Prophet Joseph Smith with the translation of the Book of Mormon, he and Joseph had “a difference of opinion . . . about the account of John the Apostle, mentioned in the New Testament [see John 21:20–23; where the Savior referred to John’s request to remain upon the earth until the Second Coming], as to whether

he died or continued to live” (Joseph Smith, in *History of the Church*, 1:35–36).

Read Doctrine and Covenants 7:1–3 to discover the answer to Joseph and Oliver’s question. If you have trouble identifying the answer, read the section summary for verses 1–3.

Beyond what is described in these verses, nothing has been revealed about the specifics of John’s ministry, whereabouts, or achievements as a translated being, so it is not appropriate to speculate about them.

 **6.** Write the following at the bottom of today’s assignments in your scripture study journal:

*I have studied Joseph Smith—History 1:66–67 and Doctrine and Covenants 6–7 and completed this lesson on (date).*

*Additional questions, thoughts, and insights I would like to share with my teacher:*

## UNIT 4: DAY 1

# Doctrine and Covenants 8–9

## Introduction

In April 1829, Oliver Cowdery began assisting the Prophet Joseph Smith with the translation of the gold plates by acting as scribe. Because the Lord had offered Oliver the gift to translate if he desired it (see D&C 6:25), Oliver “became exceedingly anxious to have the power to translate bestowed upon him” (Joseph Smith, in *History of the Church*, 1:36). In response, the Lord said that He would give Oliver the ability to translate, according to Oliver’s faith.

As Oliver made an attempt to translate, he apparently started well but “did not continue as [he had] commenced” (D&C 9:5). The Prophet received the revelation in Doctrine and Covenants 9, which explains why Oliver’s efforts to translate were unsuccessful. The Lord instructed Oliver that it was no longer expedient for him to translate. Instead, Oliver should focus on his role as a scribe for Joseph. Doctrine and Covenants sections 8–9, along with section 6, are foundational revelations regarding the Holy Ghost and ways we can seek for and recognize revelation from the Lord.



## Doctrine and Covenants 8

*The Lord teaches Oliver Cowdery about the gift of revelation*

Have you ever wondered how to recognize when God is speaking to you or answering your prayers?

Read Doctrine and Covenants 8:1 to see how the Lord instructed Oliver Cowdery to pray. Then read Doctrine and Covenants 8:2–3, and mark phrases that describe how the Lord said He would answer Oliver’s prayers. Doctrine and Covenants 8:2–3 is a scripture mastery passage. You may want to mark it in a distinctive way so you can locate it in the future.

-  **1.** In your scripture study journal, make two columns. Label the first column *Seeking Revelation from God*. Label the second column *Receiving Revelation from God*. In the first column, write at least one principle you learn from Doctrine and Covenants 8:1 about ways to seek for revelation. In the second column, write a truth the Lord taught in verses 2–3 about how He speaks to us.

Do you remember the story of Moses parting the Red Sea? The Lord had commanded Moses to free the enslaved children of Israel. Later, with the Egyptian army in pursuit, Moses found himself and his people trapped on the shores of the Red Sea. According to Doctrine and Covenants 8:2–3, how did the Lord inspire Moses to part the Red Sea?



One truth we learn from these verses is that **the Lord speaks to our minds and hearts by the power of the Holy Ghost**. Think about times when the Lord has spoken to you in this way.

In the following statements, President Boyd K. Packer, President of the Quorum of the Twelve Apostles, and Elder Richard G. Scott of the Quorum of the Twelve Apostles described how God speaks to them.

President Packer said:



“You can learn now, in your youth, to be led by the Holy Ghost.

“As an Apostle I listen now to the same inspiration, coming from the same source, in the same way, that I listened to as a boy. The signal is much clearer now” (“Prayers and Answers,” *Ensign*, Nov. 1979, 21).

Elder Scott taught:

“An impression to the *mind* is very specific.

“Detailed words can be heard or felt and written as though the instruction were being dictated.

“A communication to the *heart* is a more general impression. The Lord often begins by giving impressions. Where there is a recognition of their importance and they are obeyed, one gains more capacity to receive more detailed instruction to the *mind*. An impression to the heart, if followed, is fortified by a more specific instruction to the *mind*” (“Helping Others to Be Spiritually Led” [address to Church Educational System religious educators, Aug. 11, 1998], 3–4; si.lds.org).

### Scripture Mastery—Doctrine and Covenants 8:2–3

To help you remember how the Lord will speak to your mind and your heart, write the passage in Doctrine and Covenants 8:2–3 on a card or paper. Work on memorizing these verses by reciting the passage each morning and evening before you say your personal prayers. Once you have memorized it, you may want to share it with a friend or family member and explain what it means to you.

-  **2.** Write in your scripture study journal about a time when Heavenly Father has spoken to your mind and heart through the Holy Ghost.

## Doctrine and Covenants 9

*The Lord explains why Oliver Cowdery struggled to translate*

What are some significant decisions you will be making in the next year? In the next 5 or 10 years? Ponder why you might want guidance from the Lord in making these significant decisions.

In Doctrine and Covenants 9 the Lord explained why Oliver Cowdery had struggled to translate the plates. The Lord’s explanation can help you understand how

to seek and receive guidance for the decisions you will make in your life.

Read Doctrine and Covenants 9:1–4, and look for the work the Lord instructed Oliver to focus on instead of translating. Then read Doctrine and Covenants 9:5–6, 11, and mark the reasons Oliver was not successful when he attempted to translate.

President Joseph Fielding Smith said: “Oliver’s failure came because he did not continue as he commenced, and the task being a difficult one, his faith deserted him” (*Church History and Modern Revelation*, 2 vols. [1953], 1:51).

What can we learn from Oliver Cowdery’s experience about what we need to do to receive revelation from the Lord? What are some ways that fear, or a lack of faith, could prevent us from receiving or acting on revelation from the Lord?

Elder Jeffrey R. Holland of the Quorum of the Twelve Apostles explained:



“In the process of revelation and making important decisions, fear plays a destructive, sometimes paralyzing role. To Oliver Cowdery, who missed the opportunity of a lifetime because he didn’t seize it in the lifetime of the opportunity, the Lord said, ‘You did not continue as you commenced.’ Does that sound familiar to those who have been illuminated and then knuckled under to second thoughts and returning doubts? . . .

“. . . After you have gotten the message, after you have paid the price to feel His love and hear the word of the Lord, go forward. Don’t fear, don’t vacillate, don’t quibble, don’t whine. . . . With the spirit of revelation, dismiss your fears and wade in with both feet” (“Cast Not Away Therefore Your Confidence,” *Ensign*, Mar. 2000, 10).

Think about a time you needed to exercise faith in order to seek for or act on an answer from the Lord. What can you do in seeking an answer?

Read Doctrine and Covenants 9:7–8, looking for another reason Oliver struggled to receive the Lord’s help in his efforts to translate. What do you think it means to “study it out in your mind”?

One lesson we can learn from these verses is that **receiving and recognizing revelation require effort on our part**. You may want to add this truth to the list of ways to seek revelation from the Lord that you made in your scripture study journal for assignment 1. Remember that we should ask the

Lord if our conclusions are correct after the process of studying out our decisions.



**3. Answer the following question in your scripture study journal: Why does the Lord require us to personally ponder and study a matter and then bring Him our decisions for confirmation instead of simply asking Him to make our decisions for us?**

Ponder how the individuals described below could use the truths in Doctrine and Covenants 9:7–8 to receive revelation concerning their circumstances.

- A young man is not sure whether he should attend college or find a job and train in a vocation.
- A young woman is trying to decide how to withdraw from her friends who have a negative influence on her.
- A young returned missionary is thinking about marriage and wonders if a specific person is an appropriate marriage partner.

Read Doctrine and Covenants 9:8–9, looking for how Oliver Cowdery could know whether his decision was right or wrong. What can we learn from verse 8 about how the Lord will answer us when we ask if a decision we are making is correct?

The burning in the bosom promised to Oliver Cowdery is only one way the Holy Ghost might confirm a correct choice. Confirmations from the Spirit can come in a variety of ways that are personal and profound.



Elder Richard G. Scott spoke about a way the Lord might cause us to “feel that it is right” (D&C 9:8): “The feeling of peace is the most common confirming witness that I personally experience. When I have been very concerned about an important matter, struggling to resolve it without success, I continued those efforts in faith. Later, an all-pervading peace has come, settling my concerns, as He has promised” (“Using the Supernal Gift of Prayer,” *Ensign* or *Liahona*, May 2007, 10).

Elder Scott also explained how an answer that his decision is not right feels to him: “That [stupor of thought], for me, is an unsettling, discomforting feeling” (“Using the Supernal Gift of Prayer,” 10).

You may want to write Elder Scott’s second statement in the margin of your scriptures beside Doctrine and Covenants 9:9 or in your scripture study journal.

In Doctrine and Covenants 9:10–14, the Lord assured Oliver that He had not condemned him for failing to translate. The Lord instructed Oliver to continue writing for the Prophet and “stand fast in the work”

the Lord had called Oliver to do (D&C 9:14). The Lord promised Oliver that continued diligence and obedience would bring eternal life.

 **4.** Using what you have learned in Doctrine and Covenants 8–9, in your scripture study journal, outline a two-to-three-minute talk on receiving revelation from the Lord. Include counsel on what we must do to seek revelation from the Lord and instruction on how He communicates with us.

 **5.** Write the following at the bottom of today's assignments in your scripture study journal:

*I have studied Doctrine and Covenants 8–9 and completed this lesson on (date).*

*Additional questions, thoughts, and insights I would like to share with my teacher:*

## UNIT 4: DAY 2

# Doctrine and Covenants 11–12

### Introduction

Shortly after the restoration of the Aaronic Priesthood in May 1829, Joseph Smith's brother Hyrum and Joseph Knight Sr. visited the Prophet in Harmony, Pennsylvania. Both men expressed their desire to serve God and assist in the Restoration. Doctrine and Covenants 11 and 12 contain the Lord's words to Hyrum Smith and the Lord's words to Joseph Knight Sr. about how they could help bring forth God's work.

### Doctrine and Covenants 11:1–14

*Hyrum Smith learns how he can help bring forth the Lord's work*

Have you ever wanted to participate in a worthwhile cause that you felt would benefit people's lives and the world? That is how many people felt about the Church in the early days of the Restoration. In fact, that is how many feel about serving in the Church—the kingdom of God on earth—today. In sections 11 and 12 of

the Doctrine and Covenants, the Lord counseled Hyrum Smith and Joseph Knight Sr. concerning their participation in the Lord's work. Read Doctrine and Covenants 11:27 and 12:7 to discover who else the Lord was referring to in these revelations.



Hyrum Smith, Joseph's older brother, was likely aware of recent events, such as the progress on the translation of the Book of Mormon and the restoration of the Aaronic Priesthood. He wanted to know how he could help Joseph in the Lord's

work. Joseph inquired of the Lord and received the revelation in Doctrine and Covenants 11 for Hyrum. Read Doctrine and Covenants 11:3, 8, 10, 14, 17, 21, and 27, and note the words *desire*, *desires*, and *desireth*. Think about the sincere feelings someone should have who truly wants to assist in the Lord's work.

 **1.** In your scripture study journal, make two columns. Label the first *Promised blessings because of his righteous desires*. Label the second *What he needed to do to claim those blessings*. Read Doctrine and Covenants 11:5–8. In the first column, list the blessings the Lord promised Hyrum Smith regarding his desire to assist in the Lord's work. In the second column, list what Hyrum needed to do to claim those divine blessings.

As you studied these verses, you may have discovered these truths: **We can receive blessings from God according to our righteous desires. If we desire to do God's work, we will be the means of doing much good.**

 **2.** Complete the following activities in your scripture study journal:

- Write a few responses to the following question: What can you do to "be the means of doing much good" in your generation?
- Read Doctrine and Covenants 11:9–14, looking for the counsel the Lord gave that would help Hyrum



accomplish much good. Write the Lord's counsel to Hyrum in your scripture study journal, and see if His counsel matches some of the ideas you wrote down.

- c. According to Doctrine and Covenants 11:12–13, how do you recognize the influence of the Spirit?

From the counsel Hyrum received, we learn that **the Spirit of the Lord leads us to do good, to be humble, and to judge righteously. The Spirit also enlightens our minds and fills our souls with joy.** It may be helpful to cross-reference these truths in Doctrine and Covenants 11:12–13 with the scripture mastery passage in Doctrine and Covenants 8:2–3.



3. Take a moment and consider situations in which you have felt the Spirit. In your scripture study journal, write about one or more of the following experiences you have had:

- a. An experience in which the Spirit led you to do good
- b. An experience when the Spirit influenced you to be humble
- c. An experience when the Spirit helped you judge righteously
- d. An experience when the Spirit enlightened you on a subject or personal matter

### Doctrine and Covenants 11:15–30

*The Lord commands Hyrum Smith to prepare for his call to preach*

Imagine watching the beginnings of what you felt would be the greatest cause in the world, knowing you could be a part of it. How much of your time would you spend thinking about that cause and planning and preparing to participate in it? Read Doctrine and Covenants 11:15–16, looking for what the Lord wanted Hyrum Smith to do.

Why do you think the Lord would command Hyrum to “wait a little longer”? Consider the facts that the Church would not be officially organized for several more months and the Book of Mormon had not yet been published. How do you think these future events would affect Hyrum's preparation to help in the Lord's work?

Read Doctrine and Covenants 11:18–20, looking for what the Lord said Hyrum would need to do to become an effective instrument in the hands of the Lord.



4. Answer one or more of the following questions in your scripture study journal:

- a. How could a young person preparing for a mission “appeal unto [the] Spirit”?
- b. What do you think it means to “cleave unto [the Lord] with all your heart”?
- c. What is the Lord asking you to “assist in bringing to light”?

Using Doctrine and Covenants 11:18–20, write a principle that states several important ways you can prepare to serve in the Lord's kingdom: \_\_\_\_\_

Read Doctrine and Covenants 11:21–22, and identify something else the Lord said Hyrum Smith would need to do to help him become an effective teacher of the gospel. What did the Lord tell Hyrum he would need to do in order to be able to declare His word?

How do you think studying the scriptures to “obtain [the Lord's] word” is different from just reading the scriptures? **Those who study the Lord's word will receive His Spirit and the power to convince others of the truth of the gospel.**

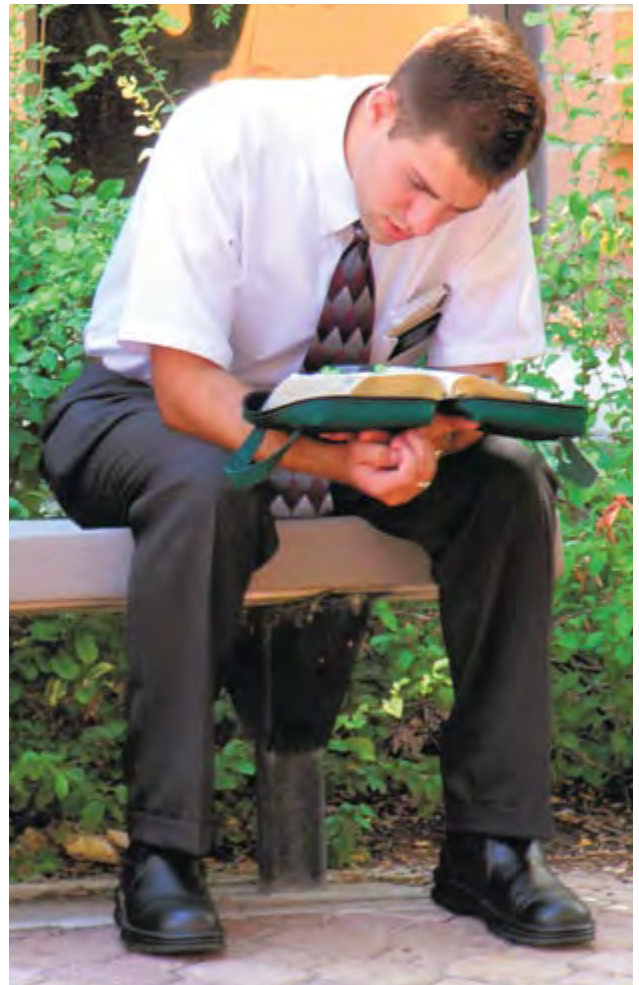

To see that Hyrum kept the Lord's commandments and followed His counsel, look at the section introduction to Doctrine and Covenants 11 and note the date that revelation was received. Then turn to the section introduction to Doctrine and Covenants 23 and note the date of that revelation. How many months later



did the Prophet Joseph Smith receive the revelation in Doctrine and Covenants 23?

Read Doctrine and Covenants 11:21, and then read Doctrine and Covenants 23:3. What did you discover? How does this apply to preparing for a mission?



Consider the counsel Elder David A. Bednar of the Quorum of the Twelve Apostles gave to young men during a priesthood session of general conference: “My earnest hope for each of you young men is that you will not simply go on a mission—but that you will become missionaries long before you submit your mission papers, long before you receive a call to serve, long before you are set apart by your stake president, and long before you enter the MTC” (“Becoming a Missionary,” *Ensign* or *Liahona*, Nov. 2005, 45).

 **5.** In your scripture study journal, write about some of the things you feel impressed to accomplish or change in the coming months to help you better obtain the word of God.

## Doctrine and Covenants 12

*The Lord counsels Joseph Knight Sr. on how he can help establish the cause of Zion*

Think of the names of a few well-known people in history. What qualities are they known for having?

Have you ever heard of a man named Joseph Knight Sr.? Read the section introduction to Doctrine and Covenants 12 to learn about Joseph Knight Sr. and an example of his contribution to the kingdom of God.

You may notice that the words of the Lord in Doctrine and Covenants 12:1–6 are the same as His words in Doctrine and Covenants 11:1–6. Often the Lord will repeat the same instructions to different individuals—“what I say unto one I say unto all” (D&C 82:5). Such is the case with Hyrum Smith (D&C 11) and Joseph Knight Sr. (D&C 12); some instruction is the same.

Although Joseph Knight Sr. was not a well-known member of the early Church, he did much good in building the kingdom of God. He sustained the Prophet with food and other supplies during the critical work of translation. Read Doctrine and Covenants 12:6–8, and mark the righteous characteristics the Lord said are needed for those who want to assist in the Lord’s work. Ponder how you are developing these characteristics in your life.

Joseph Knight Sr. consistently tried to live these righteous characteristics. He helped the Prophet throughout his ministry temporally and spiritually. Many years after the Prophet Joseph Smith received the revelation in Doctrine and Covenants 12, he recorded the following: “Joseph Knight, Sen., . . . has been faithful and true, and even-handed [fair] and exemplary, and virtuous and kind, never deviating to the right hand or to the left. . . . He is a righteous man” (in *History of the Church*, 5:124).

 **6.** To help you reflect on and apply what you have learned today, finish this phrase in your scripture study journal: *In order to assist the Lord in His work, I will . . .*

 **7.** Write the following at the bottom of today’s assignments in your scripture study journal:

*I have studied Doctrine and Covenants 11–12 and completed this lesson on (date).*

*Additional questions, thoughts, and insights I would like to share with my teacher:*

## UNIT 4: DAY 3

# Joseph Smith— History 1:68–75; Doctrine and Covenants 13

### Introduction

While translating the portion of the Book of Mormon plates concerning the ministry of the resurrected Jesus Christ among the Nephites (3 Nephi 11–28), the Prophet Joseph Smith and Oliver Cowdery had questions about baptism. They went to the woods near Joseph’s farm in Harmony, Pennsylvania, to inquire of the Lord concerning this important matter. While they were praying, an angel appeared to them. He conferred the Aaronic Priesthood on them and directed them to baptize one another in the nearby Susquehanna River. Following Joseph’s and Oliver’s baptisms, the angel instructed them to ordain each other to the Aaronic Priesthood. Joseph first laid his hands on Oliver and ordained him to the Aaronic Priesthood, and then Oliver did the same to Joseph.

## Joseph Smith—History 1:68–72; Doctrine and Covenants 13

*John the Baptist confers the Aaronic Priesthood on Joseph Smith and Oliver Cowdery*

 1. Without looking in your scriptures, answer the following questions in your scripture study journal as best you can:

- a. On what date was the Aaronic Priesthood restored?
- b. What was the name of the angel who restored the Aaronic Priesthood to Joseph Smith and Oliver Cowdery?
- c. What did the angel do to confer the Aaronic Priesthood on Joseph and Oliver?
- d. What else did the angel tell Joseph Smith and Oliver Cowdery they would receive after the Aaronic Priesthood?

Read Joseph Smith—History 1:68–72, and check your answers. You may want to write the following doctrine next to Joseph Smith—History 1:68: ***The priesthood is conferred by the laying on of hands.*** Accordingly, John the Baptist, as a resurrected person, conferred the Aaronic Priesthood upon Joseph Smith and Oliver Cowdery.

Look back at Joseph Smith—History 1:68, searching for what Joseph and Oliver were doing that led them to ask the Lord about baptism and receiving a remission of their sins. Joseph Smith—History 1:69 contains the words John the Baptist spoke to Joseph Smith and Oliver Cowdery.

The restoration of the Aaronic Priesthood is so important that these words were also included in the Doctrine and Covenants as section 13, which is a scripture mastery passage. You may want to mark it in a distinctive way so you can locate it easily in the future.

What is the function or purpose of a door?

How does a key relate to a door's function?

The Lord uses a key as a symbol to represent the authority of the priesthood that unlocks eternal



opportunities and blessings. Search Doctrine and Covenants 13, looking for the keys associated with the Aaronic Priesthood. Consider marking these keys in your scriptures as you find them.

 2. In your scripture study journal, complete the following list by writing the three keys mentioned in Doctrine and Covenants 13:

*The Aaronic Priesthood holds the keys of:*

- 1)
- 2)
- 3)

Elder Dallin H. Oaks of the Quorum of the Twelve Apostles explained the keys of the Aaronic Priesthood and the blessings they make available to members of the Church:



“What does it mean that the Aaronic Priesthood holds ‘the key of the ministering of angels’ and of the ‘gospel of repentance and of baptism, and the remission of sins’? The meaning is found in the ordinance of baptism and in the sacrament. Baptism is for the remission of sins, and the sacrament is a renewal of the covenants and blessings of baptism. Both should be preceded by repentance. . . .

“Not one of [us] has lived without sin since [our] baptism. Without some provision for further cleansing after our baptism, each of us is lost to things spiritual. . . .

“We are commanded to repent of our sins and to come to the Lord with a broken heart and a contrite spirit and partake of the sacrament in compliance with its covenants. When we renew our baptismal covenants in this way, the Lord renews the cleansing effect of our baptism. . . .

“We cannot overstate the importance of the Aaronic Priesthood in this. All of these vital steps pertaining to the remission of sins are performed through the saving ordinance of baptism and the renewing ordinance of the sacrament. Both of these ordinances are officiated by holders of the Aaronic Priesthood under the direction of the bishopric, who exercise the keys of the gospel of repentance and of baptism and the remission of sins” (“The Aaronic Priesthood and the Sacrament,” *Ensign*, Nov. 1998, 37–38).

Consider how the keys of the Aaronic Priesthood help us receive the blessings of the Atonement of Jesus Christ. According to Elder Oaks, who directs the keys of the gospel of repentance and baptism in each ward?

President Gordon B. Hinckley explained the key to the ministering of angels this way:



“When Wilford Woodruff, a man who had lived many years and had many experiences, was the President of the Church, he said to the boys of the Aaronic Priesthood: ‘I desire to impress upon you the fact that it does not make any difference

whether a man is a Priest or an Apostle, if he magnifies his calling. A Priest holds the keys of the ministering of angels,’ said he. ‘Never in my life, as an Apostle, as a Seventy, or as an Elder, have I ever had more of the protection of the Lord than while holding the office of a Priest.’ (*Millennial Star*, 53:629.)

“Think of it, my dear young brethren. This priesthood which you hold carries with it the keys of the ministering of angels. That means, as I interpret it, that if you live worthy of the priesthood, you have the right to receive and enjoy the very power of heavenly beings to guide you, to protect you, to bless you. What boy, if he is thoughtful, would not welcome this remarkable blessing?” (“The Priesthood of Aaron,” *Ensign*, Nov. 1982, 45).

Elder Oaks gave some additional insights into the key of the ministering of angels:

“As a young holder of the Aaronic Priesthood, I did not think I would see an angel, and I wondered what such appearances had to do with the Aaronic Priesthood.

“But the ministering of angels can also be unseen. Angelic messages can be delivered by a voice or merely by thoughts or feelings communicated to the mind. . . .

“In general, the blessings of spiritual companionship and communication are only available to those who are clean. . . . So it is that those who hold the Aaronic Priesthood open the door for all Church members who worthily partake of the sacrament to enjoy the companionship of the Spirit of the Lord and the ministering of angels” (“The Aaronic Priesthood and the Sacrament,” 39).

-  **3.** Answer the following question in your scripture study journal: How might understanding the power of the Aaronic Priesthood affect your thoughts or actions as you prepare, administer, or partake of the sacrament this Sunday?

### **Scripture Mastery—Doctrine and Covenants 13:1**

-  **4.** Write out Doctrine and Covenants 13:1 in your scripture study journal. Recite the passage aloud. Then cover part of the passage and recite it again. Continue covering more and more of the passage and repeating it aloud until you have it memorized.



## Joseph Smith—History 1:73–75

*Joseph Smith and Oliver Cowdery experience great blessings following their baptism*

The Lord poured out great blessings upon Joseph Smith and Oliver Cowdery after their baptism. Read Joseph Smith—History 1:73–74. You may want to mark words or phrases that describe what Joseph and Oliver experienced.

It is important to note that Joseph and Oliver experienced the *power* of the Holy Ghost, since they had not yet been given the Melchizedek Priesthood for conferring the *gift* of the Holy Ghost (see Joseph Smith—History 1:70; see also Bible Dictionary or Guide to the Scriptures, “Holy Ghost”).

From what Joseph and Oliver experienced on this occasion, described in Joseph Smith—History 1:74, complete the following principle: **The Holy Ghost helps us understand the \_\_\_\_\_ and \_\_\_\_\_ of the scriptures.**



**5.** In your scripture study journal, write your thoughts about the following questions:

- a. Why do you think we need the Holy Ghost to help us understand the scriptures?
- b. When have you felt the Holy Ghost help you understand the “true meaning and intention” of the scriptures?
- c. What can you do to invite the help of the Holy Ghost as you study the scriptures?
- d. How can renewing your baptismal covenants by partaking of the sacrament affect your understanding of the scriptures?

To conclude this lesson, read Oliver Cowdery’s description of the events surrounding the restoration of the Aaronic Priesthood, which can be found after the conclusion of Joseph Smith—History. As you read, you may want to mark words or phrases that stand out to you. What can you learn from Oliver’s description?



**6.** Write the following at the bottom of today’s assignments in your scripture study journal:

*I have studied Joseph Smith—History 1:68–75 and Doctrine and Covenants 13 and completed this lesson on (date).*

*Additional questions, thoughts, and insights I would like to share with my teacher:*

## UNIT 4: DAY 4

# Doctrine and Covenants 14–16

## Introduction

In the latter part of May 1829, Joseph Smith and Oliver Cowdery endured threats from mobs while completing the translation of the Book of Mormon. To help them escape the persecution, David Whitmer helped them move from Harmony, Pennsylvania, to the Whitmer home in Fayette, New York. The Whitmer family took great interest in the unfolding events of the Restoration. Joseph Smith described David, John, and Peter Whitmer Jr. as “zealous friends and assistants in the work; and . . . anxious to know their respective duties” (in *History of the Church*, 1:49). The Prophet prayed and received the word of the Lord directed to each of these three brothers.

## Doctrine and Covenants 14

*The Lord calls David Whitmer to assist in the latter-day work*

The following account describes the miraculous events that allowed David Whitmer to help Oliver Cowdery and Joseph Smith escape from their persecutors:

David Whitmer was planting wheat on the family farm in Waterloo, New York, near Fayette, when he was asked to go to Harmony, Pennsylvania, to help Joseph Smith and Oliver Cowdery. He determined to do this after he had completed his farming duties. He was able to harrow his whole field in one day, from the morning to the evening. The next day he was going to fertilize the field, and his sister told him about three men she had seen sowing the plaster the day before in the “forenoon.” Following is Lucy Mack Smith’s account of this miraculous event:

“David went to the field, and found that he had two heavy days’ work before him. . . . He then fastened his horses to the harrow, and instead of dividing the field into what is, by farmers, usually termed lands, drove around the whole of it, continuing thus till noon, when, on stopping for dinner, he looked around, and discovered to his surprise, that he had harrowed in full half the wheat. After dinner he went on as before, and by evening he finished the whole two days’ work.



“His father, on going into the field the same evening, saw what had been done, and he exclaimed, ‘There must be an overruling hand in this, and I think you would better go down to Pennsylvania as soon as your plaster of paris is sown.’

“The next morning, David took a wooden measure under his arm and went out to sow the plaster, which he had left, two days previous, in heaps near his sister’s house, but, on coming to the place, he discovered that it was gone! He then ran to his sister, and inquired of her if she knew what had become of it. Being surprised she said, ‘Why do you ask me? was it not all sown yesterday?’

“‘Not to my knowledge,’ answered David.

“‘I am astonished at that,’ replied his sister, ‘for the children came to me in the forenoon, and begged of me to go out and see the men sow plaster in the field, saying, that they never saw anybody sow plaster so fast in their lives. I accordingly went, and saw three men at work in the field, as the children said, but, supposing that you had hired some help, on account of your hurry, I went immediately into the house, and gave the subject no further attention.’

“David made considerable inquiry in regard to the matter, both among his relatives and neighbors, but was not able to learn who had done it” (*History of Joseph Smith by His Mother*, ed. Preston Nibley [1958], 148–49).

Imagine that you were in David Whitmer’s situation. How would these miracles affect you?



After David Whitmer brought the Prophet and Oliver Cowdery to Fayette, New York, the Lord announced the coming forth of His work in the latter days and promised blessings to all those who take part in it (see D&C 14:1–5). Read Doctrine and Covenants 14:6–7, looking for what the Lord directed David to do and the gift he would receive as a result. What gift did the Lord promise him? What was David required to do to receive this blessing?



**1.** In your scripture study journal, write your thoughts about the following questions:

- Eternal life means living forever as families in God’s presence and becoming like Him. How does this definition help you understand why eternal life “is the greatest of all the gifts of God”?
- How can the promise of eternal life inspire you to keep God’s commandments and endure to the end?

In Doctrine and Covenants 14:7, the Lord taught an important principle that applies to each one of us: **If we keep God’s commandments and endure to the end, we will receive eternal life.** Consider writing this principle in your scriptures or in your scripture study journal.

To better understand this principle, consider what it might mean to endure to the end in the following situations:

- A young man who recently joined the Church feels like he has no friends in his ward.
- A young woman gets a disease that requires continual medical attention and personal care from others.
- A young man or young woman’s parents were recently divorced, and one of the parents is not active in the Church.
- A young man or young woman is continually struggling with a temptation that can lead to addiction.

Read Doctrine and Covenants 14:8 to learn of another blessing the Lord said David Whitmer would receive based on his obedience.

Shortly after this revelation was received, David Whitmer became one of the Three Witnesses of the Book of Mormon. He saw the angel Moroni and the gold plates, and he heard God’s voice testifying of the truthfulness of the record.



**2.** Read Doctrine and Covenants 14:11, where the Lord gave David Whitmer another promise based on his faithfulness. In your scripture study journal, in your own words, write an “if-then” principle you find in this verse. (One way to write this can be found at the end of this lesson.)

## Doctrine and Covenants 15–16

*Jesus Christ teaches John and Peter Whitmer what is of most worth to them*

To study the revelations given to John and Peter Whitmer, invite a family member or friend to read a few verses with you if possible. Read Doctrine and Covenants 15:1 yourself, and then have your family member or friend read Doctrine and Covenants 16:1. Likewise read verses 2–6 of both sections, alternating back and forth between verses in the same manner. Determine what is unusual about these two revelations.

### Using Your Own Words

As you express doctrines and principles in your own words, you develop the ability and confidence to explain the gospel to others.

What is the only difference in the wording of these two revelations?

Since verses 2–6 in these revelations are identical, it seems the Lord could have given one revelation and addressed it to both men. What can we learn from the fact that He took time to speak to both John and Peter individually?

At times the Lord may reveal the same message to different individuals because they may have similar needs, circumstances, or desires. To identify the desire that John and Peter Whitmer had in common, read Doctrine and Covenants 15:3–4 and Doctrine and Covenants 16:3–4 again. What did both John and Peter Whitmer desire?

In these revelations the Lord taught that **our efforts to bring others to Jesus Christ are of great worth to us**. As you help bring people to Jesus Christ, they will also understand that God knows and loves them.

These revelations also teach that **God knows us personally**. He knows what is best for us.



 **3.** In your scripture study journal, write your thoughts about how a priesthood blessing or mission call can show that God knows us personally.

Elder David A. Bednar of the Quorum of the Twelve Apostles gave an example of the truth that God knows us personally:

“Some time ago I spoke with a priesthood leader who was prompted to memorize the names of all of the



youth ages 13 to 21 in his stake. Using snapshots of the young men and women, he created flash cards that he reviewed while traveling on business and at other times. This priesthood leader quickly learned all of the names of the youth.

“One night the priesthood leader had a dream about one of the young men whom he knew only from a picture. In the dream he saw the young man dressed in a white shirt and wearing a missionary name tag. With a companion seated at his side, the young man was teaching a family. The young man held the Book of Mormon in his hand, and he looked as if he were testifying of the truthfulness of the book. The priesthood leader then awoke from his dream.

“At an ensuing priesthood gathering, the leader approached the young man he had seen in his dream and asked to talk with him for a few minutes. After a brief introduction, the leader called the young man by name and said: ‘I am not a dreamer. I have never had a dream about a single member of this stake, except for you. I am going to tell you about my dream, and then I would like you to help me understand what it means.’

“The priesthood leader recounted the dream and asked the young man about its meaning. Choking with emotion, the young man simply replied, ‘It means God knows who I am.’ The remainder of the conversation between this young man and his priesthood leader was most meaningful, and they agreed to meet and counsel together from time to time during the following months” (“The Tender Mercies of the Lord,” *Ensign* or *Liahona*, May 2005, 100).

Ponder (or discuss with the person who read with you) why it can be helpful for us to realize that God knows us personally.

 **4.** Write in your scripture study journal about a situation in which understanding that God knows you personally helped you in some way, or write about how understanding that God knows you personally can influence the decisions you make daily.

 **5.** Write the following at the bottom of today’s assignments in your scripture study journal:

*I have studied Doctrine and Covenants 14–16 and completed this lesson on (date).*

*Additional questions, thoughts, and insights I would like to share with my teacher:*

*Note for assignment 2:* One way you could state a principle found in Doctrine and Covenants 14:11 is: **If we faithfully assist the Lord in His work, then He will bless us spiritually and temporally.**

# Doctrine and Covenants 17

## Introduction

While translating the Book of Mormon, the Prophet Joseph Smith learned that three witnesses would be permitted to see the plates “by the power of God” (see 2 Nephi 27:12–14; Ether 5:2–4). When Oliver Cowdery and David Whitmer learned of this, both of them felt an inspired desire to be witnesses. In a previous revelation (D&C 5), the Lord told Martin Harris that if he was sufficiently humble and obedient he would be permitted to see the plates. Oliver Cowdery, David Whitmer, and Martin Harris asked the Prophet to inquire of the Lord if they would be allowed to have this opportunity. The revelation you will study today, Doctrine and Covenants 17, confirmed that these three men would be permitted to view the plates and other related objects if they exercised sufficient faith.

## Doctrine and Covenants 17

*The Lord tells Oliver Cowdery, David Whitmer, and Martin Harris that if they have sufficient faith they will be allowed to see the plates and other sacred items*

Two places in the Book of Mormon contain prophecy about witnesses who would see and testify of the book or plates containing the record. Read 2 Nephi 27:12–14 and Ether 5:2–4, and think about what it might be like to be a witness of the gold plates. From what you learn in those scriptures, how would three of those witnesses be shown the record?



Oliver Cowdery

David Whitmer

Martin Harris

Through revelation, the Lord told Joseph Smith that Oliver Cowdery, David Whitmer, and Martin Harris would be allowed to see the plates. Read Doctrine and Covenants 17:1. In addition to the plates, what other objects would these witnesses be able to see?

(Footnote 1*h* contains references to what “the miraculous directors” are, including 1 Nephi 16:10, 16, 26 and Alma 37:38–47.)

Think about how these sacred items (such as the sword of Laban and the Liahona) could provide further evidence of the reality of the people and events recorded in the Book of Mormon.

Read Doctrine and Covenants 17:2–3. What did the Lord say the witnesses needed before they could see the plates? \_\_\_\_\_



1. Answer the following question in your scripture study journal: Why do you think these witnesses needed to have faith before they could see the gold plates?

Although we may not receive a witness in the same way the Three Witnesses did, we too can receive a witness of truths we desire to know. Ponder what Doctrine and Covenants 17:1–3 teaches about how we can receive our own witness of gospel truths. Then complete the following principle based on what you learn from these verses: **If we \_\_\_\_\_, we can receive a witness of the truths we desire to know.**



2. In your scripture study journal, describe how you have exercised faith in God to obtain a witness of the Book of Mormon and other gospel truths. Or, if you feel you have yet to obtain this witness, explain how you can exercise faith so you can obtain a testimony of the Book of Mormon.

Joseph Smith’s mother, Lucy Mack Smith, wrote about how Martin Harris was told he could be one of the Three Witnesses. After an evening spent reading from the newly completed Book of Mormon manuscript, “the next morning, after attending to the usual services, namely, reading, singing and praying, Joseph arose from his knees, and approaching Martin Harris with a solemnity that thrills through my veins to this day, when it occurs to my recollection, said, ‘Martin Harris, you have got to humble yourself before God this day, that you may obtain a forgiveness of your sins. If you do, it is the will of God that you should look upon the plates, in company with Oliver Cowdery and David Whitmer’” (*History of Joseph Smith by His Mother*, ed. Preston Nibley [1958], 151–52).

Ponder the following questions:

- Why do you think it is necessary to be humble when we seek God’s forgiveness?
- Why do you think we need to seek God’s forgiveness when we want to receive a witness of truth from Him?

Imagine being chosen to be one of the Three Witnesses who were permitted to see the plates “by the power of God.” What responsibility would you feel after such an experience? The Lord spoke of their responsibility of being witnesses of the plates. Read Doctrine and Covenants 17:3–5, looking for what the Lord commanded the Three Witnesses to do after they had seen the plates.

Consider the responsibility we have when the Lord gives us a witness of divine truths. You may want to mark phrases in verse 3 that teach the following principle: **After we obtain a witness of the truth, then we have a responsibility to testify of it.** Think about how your willingness to testify of the truth is also a demonstration of your faith in Jesus Christ.

 **3.** In your scripture study journal, list a few doctrines and principles of the gospel that you know are true. Share your testimony, feelings, or thoughts about these principles with a parent or sibling.

Soon after the revelation in Doctrine and Covenants 17 was given, the Prophet Joseph Smith, David Whitmer, Oliver Cowdery, and Martin Harris went to the woods near the Whitmer home to “try to obtain, by fervent and humble prayer” the promised witness. Joseph Smith recorded that after two unsuccessful attempts, “Martin Harris proposed that he should withdraw himself from us, believing, as he expressed himself, that his presence was the cause of our not obtaining what we wished for. He accordingly withdrew from us, and we knelt down again, and had not been many minutes engaged in prayer, when presently we beheld a light above us in the air, of exceeding brightness; and behold, an angel stood before us. In his hands he held the plates which we had been praying . . . to have a view of. He turned over the leaves one by one, so that we could see them, and discern the engravings thereon distinctly. . . . We heard a voice from out of the bright light above us, saying, ‘These plates have been revealed by the power of God, and they have been translated by the power of God. The translation of them which you have seen is correct, and I command you to bear record of what you now see and hear.’

“I now left David and Oliver, and went in pursuit of Martin Harris, whom I found at a considerable distance, fervently engaged in prayer. He soon told me, however, that he had not yet prevailed with the Lord, and earnestly requested me to join him in prayer, that he also might realize the same blessings which we had just received. We accordingly joined in prayer, and ultimately obtained our desires, for before we had yet finished, the same vision was opened to our view, at least it was again opened to me, and I once

more beheld and heard the same things; whilst at the same moment, Martin Harris cried out, apparently in an ecstasy of joy, “‘Tis enough; ‘tis enough; mine eyes have beheld; mine eyes have beheld’” (in *History of the Church*, 1:54–55).

Think about being entrusted with some important information that you were not allowed to share with anyone for a long time. How would you feel when you were finally allowed to share it? Think about what it would have been like for Joseph Smith to be the only witness of the Book of Mormon plates for so many years. How would you have felt in his position? How do you think Joseph Smith felt knowing that others could now add their witnesses and testimonies to his?

The following account from Lucy Mack Smith, Joseph Smith’s mother, describes how Joseph felt after the Three Witnesses had seen the plates: “When they returned to the house it was between three and four o’clock p. m. Mrs. Whitmer, Mr. Smith [Joseph Smith Sr.] and myself, were sitting in a bedroom at the time. On coming in, Joseph threw himself down beside me, and exclaimed, ‘Father, mother, you do not know how happy I am: the Lord has now caused the plates to be shown to three more besides myself. They have seen an angel, who has testified to them, and they will have to bear witness to the truth of what I have said, for now they know for themselves, that I do not go about to deceive the people, and I feel as if I was relieved of a burden which was almost too heavy for me to bear, and it rejoices my soul, that I am not any longer to be entirely alone in the world.’ Upon this,



Martin Harris came in: he seemed almost overcome with joy, and testified boldly to what he had both seen and heard. And so did David and Oliver, adding that no tongue could express the joy of their hearts, and the greatness of the things which they had both seen and heard” (*History of Joseph Smith by His Mother*, 152–53).

 **4.** In your scripture study journal, describe what it feels like to have others around you who have also received a witness of what you know is true. How do their testimonies help you?

Elder Loren C. Dunn of the Seventy spoke of the importance of witnesses in the Lord’s work: “The law of witnesses has always been a part of the Lord’s work



on earth. This law states that ‘in the mouth of two or three witnesses shall every word be established’ (2 Cor. 13:1; see also Deut. 17:6; 19:15; Matt. 18:15–16; John 8:12–29). This witness confirms that certain events took place and that God-given doctrine and principles are true” (“Witness,” *Ensign*, Nov. 1995, 28). The Lord used the law of witnesses to confirm the reality of the plates.

A few days after the gold plates were shown to the Three Witnesses by the power of God, the Prophet Joseph Smith was allowed to show the plates to “a few according to the will of God, to bear testimony of his word unto the children of men” (2 Nephi 27:13; see also Ether 5:2). Read “The Testimony of Three Witnesses” and “The Testimony of Eight Witnesses” (found after the introduction to the Book of Mormon). Notice the differences in their experiences and the similarities of their testimonies. Also notice that the Eight Witnesses described the plates as having “the appearance of gold” and the engravings having “the appearance of ancient work.” Since they did not know if the plates were real gold or that the engravings were actual ancient writings, they testified only of what they honestly knew to be true.



**5. Imagine that your testimony of the Book of Mormon could be added to each copy of the Book of Mormon.**

On a blank page in your scripture study journal, create your own personal witness page. Include what you know is true about the Book of Mormon that you want others to know as well.

Doctrine and Covenants 17:6 contains the Savior’s testimony of the Book of Mormon. Mark the witness that He gave to the world in this verse, or write His testimony in your scripture study journal. You may also want to write ***Jesus Christ testified that the Book of Mormon is true*** in your scripture study journal or the margin of your scriptures near verse 6. Ponder how the Lord’s testimony of the Book of Mormon influences your testimony.

After their remarkable experience, each of the Three Witnesses endured severe trials and their faith in God and testimonies of the gospel were challenged. During their struggles, all three left the Church, though Martin Harris and Oliver Cowdery later returned and remained faithful for the remainder of their lives. However, none of the Three Witnesses ever denied their witnesses of the Book of Mormon.

Although we do not know the specific reason why each of the Three Witnesses left the Church after having experienced such a powerful witness, the

Lord’s warning to the Prophet Joseph Smith recorded in Doctrine and Covenants 3:4 helps us understand how such things can happen: “For although a man may have many revelations, and have power to do many mighty works, yet if he boasts in his own strength, and sets at naught the counsels of God, and follows after the dictates of his own will and carnal desires, he must fall and incur the vengeance of a just God upon him.” Each of the Three Witnesses, however, continued to bear faithful witness of the Book of Mormon throughout their lives.

Oliver Cowdery testified: “I wrote with my own pen, the entire Book of Mormon (save a few pages) as it fell from the lips of the Prophet Joseph Smith, and he translated it by the gift and power of God, by the means of the Urim and Thummim, or, as it is called by that book, ‘Holy Interpreters.’ I beheld with my eyes, and handled with my hands, the gold plates from which it was transcribed. . . . That book is *true*. Sidney Rigdon did not write it; Mr. Spaulding did not write it. I wrote it myself, as it fell from the lips of the Prophet. It contains the everlasting gospel. . . . It contains principles of salvation; and if you, my hearers, will walk by its light and obey its precepts, you will be saved with an everlasting salvation in the kingdom of God on high” (in “Last Days of Oliver Cowdery,” *Deseret News*, Apr. 13, 1859, 48).

A newspaper called the *Richmond Democrat* carried the following account of David Whitmer bearing witness of the Book of Mormon a few days before he died: “On Sunday evening, at 5:30 (Jan. 22, 1888), Mr. Whitmer called his family and some friends to his bedside. . . . He then addressed himself to all around his bedside in these words: ‘Now you must all be faithful in Christ. I want to say to you all, the Bible and the record of the Nephites (Book of Mormon) is true, so you can say that you have heard me bear my testimony on my death-bed. All be faithful in Christ, and your reward will be according to your works. God bless you all. My trust is in Christ forever, worlds without end. Amen’” (*Richmond Democrat*, Feb. 2, 1888, quoted in Andrew Jenson, *Latter-day Saint Biographical Encyclopedia*, 4 vols. [1901], 1:270).

Shortly before he died, Martin Harris testified: “Yes, I did see the plates on which the Book of Mormon was written; I did see the angel; I did hear the voice of God; and I do know that Joseph Smith is a Prophet of God, holding the keys of the Holy Priesthood” (“The Last Testimony of Martin Harris,” recorded by

William H. Homer in a statement sworn before J. W. Robinson, Apr. 9, 1927, HDC). (See also *Doctrine and Covenants Student Manual* [Church Educational System manual, 2001], 33.)

Read Doctrine and Covenants 17:7–9, and mark the promises the Lord made to the Three Witnesses if they were faithful in declaring their testimonies. Notice the phrase “righteous purposes” in verse 9. Think about the righteous purposes the Lord desired the Three Witnesses to fulfill by declaring their witness of the gold plates and the Book of Mormon. (You may also want to review Doctrine and Covenants 17:4 as you think about this question.)

 **6.** In your scripture study journal, answer the following question: What might be a righteous purpose for which the Lord could give you a witness of the truths you desire to know?



Remember that we can gain or strengthen a testimony as we share it. President Boyd K. Packer of the Quorum of the Twelve Apostles taught:

“It is not unusual to have a missionary say, ‘How can I bear testimony until I get one? How can I testify that God lives, that Jesus is the Christ, and that the gospel is true? If I do not have such a testimony, would that not be dishonest?’

“Oh, if I could teach you this one principle. A testimony is to be *found* in the *bearing* of it! Somewhere in your quest for spiritual knowledge, there is that ‘leap of faith,’ as the philosophers call it. It is the moment when you have gone to the edge of the light and stepped into the darkness to discover that the way is lighted ahead for just a footstep or two. ‘The spirit of man,’ as the scripture says, indeed ‘is the candle of the Lord.’ (Prov. 20:27.)

“It is one thing to receive a witness from what you have read or what another has said; and that is a necessary beginning. It is quite another to have the Spirit confirm to you in your bosom that what *you* have testified is true. Can you not see that it will be supplied as you share it? As you give that which you have, there is a replacement, with increase! . . .

“To speak out is the test of your faith” (“Candle of the Lord,” *Ensign*, Jan. 1983, 54).

Ponder who you could share your testimony with who might benefit from hearing it. Share your testimony with that person this week.



**7.** Write the following at the bottom of today’s assignments in your scripture study journal:

*I have studied Doctrine and Covenants 17 and completed this lesson on (date).*

*Additional questions, thoughts, and insights I would like to share with my teacher:*

## UNIT 5: DAY 2

# Doctrine and Covenants 18

## Introduction

The revelation in Doctrine and Covenants 18 was given in June 1829, shortly after Peter, James, and John conferred the Melchizedek Priesthood upon Joseph Smith and Oliver Cowdery. Their visitation emphasized the important role of Apostles in the foundation of the Church of Jesus Christ. Doctrine and Covenants 18:1–16 focuses on the calling Oliver Cowdery and David Whitmer received to be servants of Jesus Christ and preach repentance to others. Doctrine and Covenants 18:17–47 teaches the importance of taking upon us the name of Jesus Christ. The Lord also mentioned the forthcoming call of the Twelve Apostles and the desire they would have to take upon themselves the name of the Savior “with full purpose of heart” (D&C 18:27). The Lord gave Oliver Cowdery and David Whitmer the unique responsibility to “search out the Twelve” (D&C 18:37).

## Doctrine and Covenants 18:1–5

### *The Lord teaches how to build up His Church*

Have you ever experienced the disturbance and destruction of an earthquake? On October 17, 1989, at 5:04 p.m., a powerful earthquake (measuring 6.9 on the Richter scale) hit the San Francisco, California, area of the United States. Thousands of buildings were damaged or destroyed. Some of the homes appeared to be fine on the outside, but officials condemned them because the foundations were cracked or not secure. What concerns would you have about living in a house with an insecure foundation?

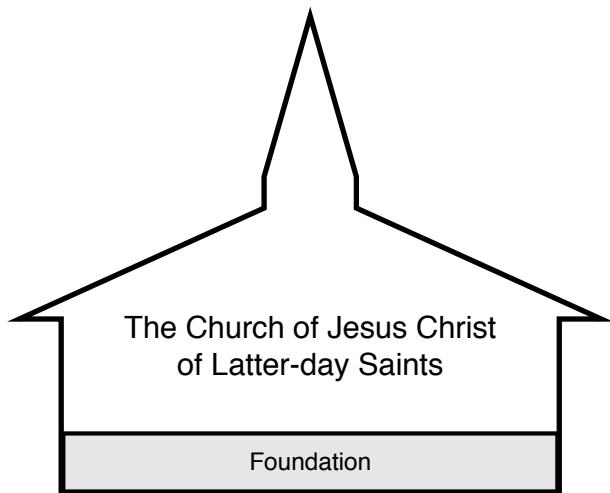

As recorded in Doctrine and Covenants 18, the Lord revealed to Joseph Smith and Oliver Cowdery how to build up His Church on a secure foundation. At the beginning of this revelation, the Lord referred to the things Oliver Cowdery had written, meaning the words of the Book of Mormon Oliver had recorded while acting as a scribe for the Prophet Joseph Smith.

Read Doctrine and Covenants 18:2–5, and identify what was written in the Book of Mormon that the Lord commanded His servants to build the Church upon.

From the Lord’s instructions we learn a central feature of the Lord’s true Church. Complete the following principle based on the revelation given in these verses:  
**The true Church is built upon \_\_\_\_\_.**

The Prophet Joseph Smith taught the following about the foundation and the rock:

“Christ was head of the Church, the chief cornerstone, the spiritual rock upon which the Church was built, and the gates of hell shall not prevail against it [see Matthew 16:18; Ephesians 2:20]. He built up the Kingdom, chose Apostles and ordained them to the Melchizedek Priesthood, giving them power [priesthood keys] to administer in the ordinances of the Gospel” (*Teachings of Presidents of the Church: Joseph Smith* [2007], 139).

“Jesus in His teachings says, ‘Upon this rock I will build my Church, and the gates of hell shall not prevail against it.’ [Matthew 16:18.] What rock? Revelation” (*Teachings: Joseph Smith*, 195).

The Lord gave a specific promise to His servants if they would build up His Church upon the secure foundation of His gospel. Read Doctrine and Covenants 18:5, and identify the Lord’s promise.

## Doctrine and Covenants 18:6–16

*Oliver Cowdery and David Whitmer are called to preach repentance*

How would you describe the spiritual and moral climate of the world we currently live in? Read Doctrine and Covenants 18:6, and notice how the Lord described the world. Identify the Lord’s solution to the increasing iniquity in the world, recorded in Doctrine and Covenants 18:9.

Think of an item in your home that you feel is valuable. Do you know approximately how much money that item is worth? One way to establish an object’s value is by determining the price someone is willing to pay for it. A person might claim that a particular object is worth a certain amount of money, but that price is accurate only if another person is willing to pay that amount for the object.

What is the worth of a soul? Doctrine and Covenants 18:10 teaches the value of a person in God’s eyes. Read this verse, looking for what the Lord declared we are worth.



**1.** In your scripture study journal, write why you think you are of such great worth to Heavenly Father and Jesus Christ.

President Dieter F. Uchtdorf of the First Presidency explained our worth to our Heavenly Father: “God sees you not only as a mortal being on a small planet who lives for a brief season—He sees you as His child. He sees you as the being you are capable and designed to become. He wants you to know that you matter to Him” (“You Matter to Him,” *Ensign or Liahona*, Nov. 2011, 22).

Each soul is important to the Lord, and Church leaders often are directed by the Spirit to minister to one particular individual. For example, President Thomas S. Monson followed the promptings of the Spirit and changed the message he had prepared in order to speak to one young girl during a general conference:



“In the balcony to my left I see a beautiful girl of perhaps ten years. Sweet little one, I do not know your name or whence you have come. This, however, I do know: the innocence of your smile and the tender expression of your eyes have persuaded me to place aside for a future time the message I had prepared for this occasion. Today, I am impressed to speak to you.”

President Monson then shared an experience that strengthened his understanding of the great love that Jesus Christ has for children. He talked about 10-year-old Christal Methvin who, with her family, lived in the Shreveport Louisiana Stake. Christal had been diagnosed with cancer, which had spread to her lungs. “The Methvin family did not despair, but rather planned a flight to Salt Lake City. Christal could receive a blessing from one of the General Authorities. The Methvins knew none of the Brethren personally, so opening before Christal a picture of all the General Authorities, a chance selection was made. By sheer coincidence, my name was selected.

“Christal never made the flight to Salt Lake City. Her condition deteriorated. The end drew nigh. But her faith did not waver. To her parents, she said, ‘Isn’t stake conference approaching? Isn’t a General Authority assigned? And why not Brother Monson? If I can’t go to him, the Lord can send him to me.’

“Meanwhile in Salt Lake City, with no knowledge of the events transpiring in Shreveport, a most unusual situation developed. For the weekend of the Shreveport Louisiana Stake Conference, I had been assigned to El Paso, Texas. President Ezra Taft Benson called me to his office and explained that one of the other Brethren had done some preparatory work regarding the stake division in El Paso. He asked if I would mind were another to be assigned to El Paso and I assigned elsewhere. Of course there was no problem—anywhere would be fine with me. Then President Benson said, ‘Brother Monson, I feel impressed to have you visit the Shreveport Louisiana Stake.’ The assignment was accepted. The day came. I arrived in Shreveport.

“That Saturday afternoon was filled with meetings. . . . Rather apologetically, Stake President Charles F. Cagle asked if my schedule would permit me time to provide a blessing to a ten-year-old girl afflicted with cancer. Her name: Christal Methvin. I responded that, if possible, I would do so, and then inquired if she would be at the conference, or was she in a Shreveport hospital? Knowing the time was tightly scheduled, President Cagle almost whispered that Christal was confined to her home—*more than eighty miles from Shreveport!*

“I examined the schedule of meetings for that evening and the next morning—even my return flight. There simply was no available time. An alternative suggestion came to mind. Could we not remember the little one in our public prayers at conference? Surely the Lord would understand. On this basis, we proceeded with the scheduled meetings.

“When the word was communicated to the Methvin family, there was understanding but a trace of disappointment as well. Hadn’t the Lord heard their prayers? Hadn’t he provided that Brother Monson would come to Shreveport? Again the family prayed, asking for a final favor—that their precious Christal would realize her desire.

“At the very moment the Methvin family knelt in prayer, the clock in the stake center showed the time to be 7:45. The leadership meeting had been inspirational. I was sorting my notes, preparing to step to the pulpit, when I heard a voice speak to my spirit. The message was brief, the words familiar: ‘Suffer the little children to come unto me, and forbid them not: for of such is the kingdom of God.’ (Mark 10:14.) My notes became a blur. My thoughts turned to a tiny girl in need of a blessing. The decision was made. The meeting schedule was altered. After all, people are more important than meetings. . . .

“I shall ever remember and never forget that early-morning journey to a heaven the Methvin family calls home. . . .

“The family surrounded Christal’s bedside. I gazed down at a child who was too ill to rise—almost too weak to speak. Her illness had now rendered her sightless. So strong was the spirit that I fell to my knees, took her frail hand in mine, and said simply, ‘Christal, I am here.’ She parted her lips and whispered, ‘Brother Monson, I just knew you would come.’ I looked around the room. No one was standing. Each was on bended knee. A blessing was given. A faint smile crossed Christal’s face. Her whispered ‘thank you’ provided an appropriate benediction. . . .

“Four days later, on Thursday, as Church members in Shreveport joined their faith with the Methvin family and Christal’s name was remembered in a special prayer to a kind and loving Heavenly Father, the pure spirit of Christal Methvin left its disease-ravaged body and entered the paradise of God. . . .

“To you, my little friend in the upper balcony, and to believers everywhere, I bear witness that Jesus of Nazareth does love little children, that he listens to your prayers and responds to them” (“The Faith of a Child,” *Ensign*, Nov. 1975, 20–22).

Read Doctrine and Covenants 18:11–12, looking for the price our Savior, Jesus Christ, paid to redeem us. (The phrase “all men” refers to everyone—all men, women, and children.) (Doctrine and Covenants 18:10–11 is a scripture mastery passage. You may want to mark it in a distinctive way so you can find it more easily.)



Because the worth of each soul is so great, how do you think Heavenly Father and Jesus Christ feel when someone repents and accepts the Savior’s sacrifice? Read Doctrine and Covenants 18:13, and identify the Lord’s response. Ponder why you think we bring great joy to the Lord when we repent.

From Doctrine and Covenants 18:14 we learn that the Lord called Oliver Cowdery and David Whitmer to “cry repentance unto this people.” Elder Neil L. Andersen of the Quorum of the Twelve Apostles explained: “Crying repentance simply means helping people return to God” (“Preparing for Your Spiritual Destiny” [Jan. 10, 2010], 7, speeches.byu.edu).

 **2.** In your scripture study journal, list some ways a young person can help someone to repent or prepare to return to God.

### Come unto Christ

To “come unto Christ” means to have faith in Him, to keep His commandments, to make covenants with God, and to repent when we make mistakes (see Moroni 10:32–34).

Read Doctrine and Covenants 18:15–16, looking for what individuals experience when they help someone come unto Jesus Christ. (Doctrine and Covenants 18:15–16 is a scripture mastery passage. You may want to mark this passage in a distinctive way to help

you find it more easily.) Based on the Lord’s promise in these verses, complete the following principle: **If we help others to repent and come unto the Lord, our joy \_\_\_\_\_.**

 **3.** In your scripture study journal, write about an experience where either you or someone you know experienced joy from helping someone to repent or to grow closer to the Lord. Also, write down one thing you will do to assist in the work of saving souls. Consider specific individuals you might help.

### Scripture Mastery—Doctrine and Covenants 18:10–11

Write the words in Doctrine and Covenants 18:10–11 on a card or small piece of paper. Carry this paper with you, and refer to it periodically throughout the day to help you remember your worth and the worth of others in the sight of God.

 **4.** Write the following phrase in your scripture study journal, writing your own name in the blanks: *The worth of \_\_\_\_\_ is so great that Jesus Christ suffered*

*and died so \_\_\_\_\_ can repent and return to Heavenly Father.* Then answer the following questions:

- How could knowing this truth influence how you view yourself?
- How could remembering the price Jesus Christ paid for the souls of others affect how you treat them?

### Scripture Mastery—Doctrine and Covenants 18:15–16

Ask a family member or friend to help you memorize Doctrine and Covenants 18:15–16. Have one person begin with the first line of the scripture mastery passage, as shown below. The other person should then try to repeat the first line from memory and then add the next line. Repeat this process, alternating from person to person, saying the previous lines and adding a line of the passage until it is completed. You may want to repeat the process until you have gone through the passage several times.

“And if it so be that you should labor all your days”

“in crying repentance unto this people,”

“and bring, save it be one soul unto me,”

“how great shall be your joy with him”

“in the kingdom of my Father!”

“And now, if your joy will be great with one soul”

“that you have brought unto me”

“into the kingdom of my Father,”

“how great will be your joy”

“if you should bring many souls unto me!”

 **5.** In your scripture study journal, write as much as you can of what you memorized of this scripture mastery passage.

### Doctrine and Covenants 18:17–25

*Jesus Christ teaches Oliver Cowdery and David Whitmer concerning the power of His name*

Think about your surname (last name) for a moment. Have you ever considered the blessings and responsibilities that come with having your name and belonging to your family? Some of these privileges might include love and acceptance, a place to live, security, and people to care for you. Your responsibilities might include treating family members with respect, doing household chores, and bringing honor to the family name.

Even if you have a less-than-ideal family life and feel your family name is not important, you took upon yourself the name of Jesus Christ when you were baptized. Read Doctrine and Covenants 18:17–25, and identify the privileges and responsibilities that come with taking upon yourself His name. Write your answers in the following chart:

Privileges	Responsibilities

According to Doctrine and Covenants 18:23, why is it important for us to take upon ourselves the name of Jesus Christ? \_\_\_\_\_

 **6.** In your scripture study journal, write down a few ways you can let others know that you have taken the name of Jesus Christ upon yourself.

## Doctrine and Covenants 18:26–47

*The Lord reveals the calling and mission of the Twelve Apostles*

In his first general conference as a newly called Apostle, Elder Jeffrey R. Holland said:



“Obviously my greatest thrill and the most joyful of all realizations is that I have the opportunity, as Nephi phrased it, to ‘talk of Christ, . . . rejoice in Christ, . . . preach of Christ, [and] prophesy of Christ’ (2 Ne. 25:26) wherever I may be and with whomever I may find myself until the last breath of my life is gone. Surely there could be no higher purpose or greater privilege than that of ‘special [witness] of the name of Christ in all the world’ (D&C 107:23).

“. . . Beyond my words and teachings and spoken witness, my life must be part of that testimony of Jesus. My very being should reflect the divinity of this work. I could not bear it if anything I might ever say or do would in any way diminish your faith in Christ, your love for this church, or the esteem in which you hold the holy apostleship.

“I do promise you—as I have promised the Lord and these my brethren—that I will strive to live worthy of this trust and serve to the full measure of my ability” (“Miracles of the Restoration,” *Ensign*, Nov. 1994, 31).

The Lord referred to the calling and mission of the Twelve Apostles in Doctrine and Covenants 18:26–32, 37–47.

 **7.** According to Doctrine and Covenants 18:26–29, the Twelve Apostles are called to preach and administer the gospel to the entire world. Read verses 30–32; then, in your scripture study journal, record what else the Lord said the Twelve Apostles were to do.

Why are some voices easier to recognize than others? Do you ever find it difficult to recognize the voice of the Lord and know when He is speaking to you?

We can hear the voice of the Lord through His servants. In Doctrine and Covenants 18, the Lord explained an additional way we can hear and become familiar with His voice. Read Doctrine and Covenants 18:34–36, 47, looking for this important way in which the Lord communicates with us. In Doctrine and Covenants 18:34 the phrase “these words” refers to the revelations the Lord had given that are now found in the Doctrine and Covenants. According to these verses, what would you say to someone who wants to know how we can hear the Lord speaking to us?

Write this principle in your scriptures or your scripture study journal: **We can hear the voice of Jesus Christ as we read the scriptures by the power of the Spirit.**



We can hear the voice of the Lord in ways that are not audible to our ears. Through the Holy Ghost we can receive feelings and messages to our mind and heart (see D&C 8:2–3). Elder M. Russell Ballard of the Quorum of the Twelve Apostles taught, “When we read and study the revelations, the Spirit can confirm in our hearts the truth of what we are learning; in this way, the voice of the Lord speaks to each one of us” (“Marvelous Are the Revelations of the Lord,” *Ensign*, May 1998, 32).

Think of an experience when you felt the Lord inspire you as you read or pondered the scriptures. Ponder the following questions:

- How could knowing that the Holy Ghost can help us hear the Savior’s voice as we read His words affect the way you think about the scriptures?
- How might that truth guide you as you choose the time, place, or environment in which you read the scriptures?



8. Write the following at the bottom of today's assignments in your scripture study journal:

*I have studied Doctrine and Covenants 18 and completed this lesson on (date).*

*Additional questions, thoughts, and insights I would like to share with my teacher:*

## UNIT 5: DAY 3

# Doctrine and Covenants 19:1–22

### Introduction

In June 1829, Joseph Smith hired the printer Egbert B. Grandin to print 5,000 copies of the Book of Mormon at a cost of \$3,000. Using his farm as collateral, Martin Harris personally guaranteed to pay the cost of printing if sales of the book did not cover the cost. Before the publication was complete, some townspeople held a meeting and passed a resolution not to purchase the Book of Mormon. Concerned about these threats, Grandin stopped printing to avoid not being paid for the work. The possibility that the Book of Mormon would not sell also put Martin Harris in danger of losing his farm.

The revelation found in Doctrine and Covenants 19 was given for Martin Harris during this time. President Joseph Fielding Smith described this revelation as “one of the great revelations given in this dispensation; there are few of greater import than this. The doctrine of the atonement of the Lord, as directly applied to the individual, and his exposition of ‘Eternal Punishment,’ as here set forth, give to the members of the Church light which was not previously known” (*Church History and Modern Revelation*, 2 vols. [1953], 1:85).

### Doctrine and Covenants 19:1–3

*The Savior declares that He accomplished the will of the Father*

Read Doctrine and Covenants 19:1–3, looking for what the Savior said about who He is and what He did. Mark words or phrases that teach that **Jesus Christ fulfilled the will of His Father** and that **Jesus Christ will judge us according to our works**.



1. In your scripture study journal, describe how knowing these truths about the Savior might have helped Martin Harris feel peace and given him strength to do the Lord's will.

### Doctrine and Covenants 19:4–12

*Jesus Christ explains eternal and endless punishment*

The Lord explained some truths that can help us understand His atoning sacrifice better. Read Doctrine and Covenants 19:4, looking for words that complete the following doctrinal statement: **Every person must \_\_\_\_\_ or \_\_\_\_\_.**

You may want to mark this phrase in your scriptures.

Read Doctrine and Covenants 19:5. How did the Savior describe the suffering of those who do not repent and will, therefore, receive His judgments? How does knowing this truth provide an added reason for us to repent of our sins?

Scan Doctrine and Covenants 19:6–7, and look for phrases that are sometimes used to describe the condition of those who do not repent. Mark the phrases “endless torment” and “eternal damnation.” What do you think of when you read these two phrases?

Search Doctrine and Covenants 19:8–12 for information to help you understand why these phrases do not refer to the length of time people will suffer for their sins.

Did you notice that “Endless” is a name for God? This means that “endless punishment” or “eternal punishment” is “God’s punishment.” What do you think “God’s punishment” means?



Elder James E. Talmage of the Quorum of the Twelve Apostles explained: “To hell there is an exit as well as an entrance. Hell is no place to which a vindictive judge sends prisoners to suffer and to be punished principally for his glory; but it is a place prepared for the teaching, the disciplining of those who failed to learn here upon the earth what they should have learned. True, we read of everlasting punishment, unending suffering, eternal damnation. That is a direful expression; but in his mercy the Lord has made plain what those words mean. ‘Eternal punishment,’ he says, is God’s punishment, for he is eternal; and that condition or state or possibility will ever exist for the sinner who deserves and really needs such condemnation; but this does not mean that the individual sufferer or sinner is to be eternally and everlastingly made to endure and suffer. No man

will be kept in hell longer than is necessary to bring him to a fitness for something better. When he reaches that stage the prison doors will open and there will be rejoicing among the hosts who welcome him into a better state. The Lord has not abated in the least what he has said in earlier dispensations concerning the operation of his law and his gospel, but he has made clear unto us his goodness and mercy through it all, for it is his glory and his work to bring about the immortality and eternal life of man” (in Conference Report, Apr. 1930, 97.)



President Joseph Fielding Smith gave this insight: “The same punishment always follows the same offense, according to the laws of God who is eternal and endless, hence it is called endless punishment, and eternal punishment, because it is the punishment which God has fixed according to unchangeable law. A man may partake of endless torment, and when he has paid the penalty for his transgression, he is released, but the punishment remains and awaits the next culprit, and so on forever” (*Doctrines of Salvation*, comp. Bruce R. McConkie, 3 vols. [1954–56], 2:228).



President J. Reuben Clark of the First Presidency provided additional insight by teaching about God’s true nature. As you read his explanation, think about how understanding the nature of God helps us understand about God’s punishment.

“I cannot subscribe to the modern doctrine that God does not punish, because I cannot throw away all of the scriptures there are in order to reach that conclusion[, but] I have a feeling that when the Lord comes to give us our reward . . . and our punishment . . . that he will give that punishment which is the very least that our transgression will justify. I believe that he will bring into his justice all of the infinite love and blessing and mercy and kindness and understanding which he has. . . .

“And on the other hand, I believe that when it comes to making the rewards for our good conduct, he will give us the maximum that it is possible to give, having in mind the offense which we have committed” (“*As Ye Sow . . .*,” Brigham Young University Speeches of the Year [May 3, 1955], 6–7).



## Doctrine and Covenants 19:13–22

### *The Savior speaks of His suffering for sin*

The Savior wants our lives to be blessed and improved through His atoning sacrifice. Read Doctrine and Covenants 19:13–17, and complete this statement:

**Those who choose not to repent will \_\_\_\_\_**

Elder Neal A. Maxwell of the Quorum of the Twelve Apostles reminded us that we have a choice to make: “We will end up either choosing Christ’s manner of living or His manner of suffering! It is either ‘suffer even as I’ (D&C 19:16–17), or overcome ‘even as [He] . . . overcame’ (Revelation 3:21)” (“Overcome . . . Even As I Also Overcame,” *Ensign*, May 1987, 72).

Ponder your own choices. Are they leading you to a more Christlike life, or are they leading you to a future of suffering for your own sins?

Most accounts of Jesus Christ’s suffering are given by someone other than Himself (see Matthew 26:36–39; Luke 22:39–44). Doctrine and Covenants 19 contains the Savior’s personal account of His suffering.





2. Read Doctrine and Covenants 19:15, 18–19, and answer the following questions in your scripture study journal:

- How did the Savior describe the suffering He experienced in Gethsemane?
- How do you feel about the Savior suffering the penalty for your sins?
- How might knowing about the Savior’s suffering have helped encourage Martin Harris to repent of his sins, as the Lord instructed him to do in this revelation?



3. Read Doctrine and Covenants 19:20, and answer the following questions in your scripture study journal:

- Why do you think the withdrawal of the Spirit would lead to suffering?
- Why might it be helpful to remember times when we had to suffer the consequences of our sins?

Think back to times when you have suffered because of your sins and felt the need for repentance. As you ponder those times, recall when you felt the Spirit’s companionship and when you felt the Spirit withdraw. What did you do to once again enjoy the companionship of the Spirit?



4. Use Doctrine and Covenants 19:13–16, 20 to answer the following question in your scripture study journal:

How is the Lord’s commandment to repent evidence of His love for us?

Sometime during the next week, share your testimony with a family member or friend about one of the doctrines or principles you learned while studying Doctrine and Covenants 19:1–22. Consider volunteering to share your experience with your teacher the next time you meet.

### Explaining, Sharing, and Testifying

Explaining doctrines and principles, sharing insights and relevant experiences, and testifying of divine truth can clarify your understanding of gospel doctrines and principles and improve your ability to teach the gospel to others. As you explain, share, and testify, the Holy Ghost will lead you to a deeper testimony of the things you are teaching.



### Scripture Mastery—Doctrine and Covenants 19:16–19

Work on memorizing Doctrine and Covenants 19:16–19 by writing the scripture mastery passage word for word on a piece of paper. Using your paper, read the passage aloud several times. Then cover (or erase) a few words or phrases on your paper. Continue to recite

the scripture mastery passage, reciting the covered portions from memory. Repeat this process until you feel comfortable reciting the passage in its entirety.



5. In your scripture study journal, write as much as you can of what you memorized of this scripture mastery passage.



6. Write the following at the bottom of today’s assignments in your scripture study journal:

*I have studied Doctrine and Covenants 19:1–22 and completed this lesson on (date).*

*Additional questions, thoughts, and insights I would like to share with my teacher:*

## UNIT 5: DAY 4

# Doctrine and Covenants 19:23–41

## Introduction

In the introduction to the last lesson, you learned that in order to guarantee E. B. Grandin’s payment for printing the Book of Mormon, Martin Harris signed a mortgage agreement on his farm. During the printing, some local citizens passed a resolution to not purchase the Book of Mormon after publication. Afraid that he would not be paid, the printer stopped the production of the Book of Mormon. The possibility that people would not buy the copies of the Book of Mormon put Martin Harris in danger of losing his farm. In the second part of this revelation for Martin Harris, Doctrine and Covenants 19:23–41, the Lord exhorted Martin to impart of his property freely to the printing of the Book of Mormon. Martin eventually sold 151 acres of his farm to cover the printing costs.

## Doctrine and Covenants 19:23–24

*The Savior testifies that peace comes by learning of Him*

When have you had to do something difficult that you knew was right but you were unsure or nervous about how it would turn out? (For example, you may have felt the need to stay away from some friends because they were a bad influence on you.) What helped you have the faith to do what you knew was right even though it was hard?



1. Answer the following questions in your scripture study journal:

- What are some difficult things you have been asked to do or may sometime be asked to do because you are a member of the Church? Why were they hard or why would they be hard for you to do?
- Would your feelings and response change depending on who asked you to do the difficult thing? Why or why not?

Read the section heading for Doctrine and Covenants 19, and mark who gave the commandment in this revelation to Martin Harris. If you were in Martin’s position, how might knowing that this commandment came from God help you? \_\_\_\_\_

Martin Harris was afraid of losing his farm because of problems that arose during the printing of the Book of Mormon. The Lord responded to Martin’s concern by revealing some things he needed to do and some things he needed to know. Read Doctrine and Covenants 19:23, and mark the Savior’s promise to Martin Harris. (Doctrine and Covenants 19:23 is a scripture mastery passage.) You may want to write the following principle in your scripture study journal: **If we learn of Christ, listen to His words, and walk in the meekness of His Spirit, then we will have peace.**



2. Answer the following question in your scripture study journal: When have you felt the peace promised in this principle as you have done such things as studying the scriptures, listening to talks in general conference and other Church meetings, and pondering the blessings of the gospel?

Read Doctrine and Covenants 19:24, looking for what Martin Harris learned about Jesus Christ. Ponder how learning this could help you feel peace when you are asked to do something difficult for the Lord.

### Scripture Mastery—Doctrine and Covenants 19:23



3. To help you memorize this scripture mastery passage, write the letters A–D in your scripture study journal. Then read Doctrine and Covenants 19:23 as many times as you can in 2 minutes. When the time is up, close your scriptures and, next to letters A–C, list the three things we must do. Then, next to the letter D, write what the Lord promised we will obtain if we do those three things.

## Doctrine and Covenants 19:25–35

### *The Lord commands Martin Harris to sell his property for the printing of the Book of Mormon*

After promising Martin Harris peace conditional upon learning of the Savior and listening to His words, the Lord gave him additional commandments and counsel. Read Doctrine and Covenants 19:26, looking for what the Lord commanded Martin Harris to do. (Martin did sell 151 acres of his farm, which made the printing of the Book of Mormon possible.)



Search Doctrine and Covenants 19:25–35, looking for the commandments and counsel the Lord gave Martin Harris. As you read, look for and consider marking the phrases “I command” and “thou shalt.”

The Lord cared for Martin Harris and gave him specific commandments for his individual circumstances. We do not have sufficient information to understand why Martin Harris was given certain commandments. However, the Lord did make clear what would happen if Martin were to disregard those commandments. Read Doctrine and Covenants 19:33, looking for what the Lord said would happen if Martin were to “slight these counsels.” In this context, the word *slight* means to disregard something because it is seen as insignificant or of little value. You might want to write this definition in your scriptures near the word *slight*.



4. Think of some of the commandments and counsel you have received from the Lord through the words of apostles and prophets, priesthood blessings (including your patriarchal blessing if you have received one), and priesthood leaders. In your scripture study journal, write about why it is important to follow this guidance.



Elder Russell M. Nelson of the Quorum of the Twelve Apostles gave the following counsel: “Keep *all* the commandments of God, knowing that they are given to bless His children and bring them joy. [You] will encounter people who pick which

commandments they will keep and ignore others that they choose to break. I call this the cafeteria approach to obedience. This practice of picking and choosing will not work. It will lead to misery. To prepare to meet God, one keeps *all* of His commandments. It takes faith to obey them, and keeping His commandments will strengthen that faith” (“Face the Future with Faith,” *Ensign* or *Liahona*, May 2011, 34).

Consider whether you have a tendency to slight, or disregard, any of the commandments the Lord has given you and whether there is a particular commandment you could obey with greater dedication.

## Doctrine and Covenants 19:36–41

### *The Lord counsels Martin Harris concerning his ministry*

Just like Martin Harris, we all have to decide whether or not we will submit our will to the will of the Father, even when what He asks is difficult. President Thomas S. Monson shared the following account of a young man who had to decide whether he would submit his will to the will of the Father. Read the first part of this story and compare this young man’s experience with that of Martin Harris.

“Jose Garcia from Old Mexico [was] born in poverty but nurtured in faith, Jose prepared for a mission call. I was present the day his recommendation was received. There appeared the statement: ‘Brother Garcia will serve at great sacrifice to his family, for he is the means of much of the family support. He has but one possession—a treasured stamp collection—which he is willing to sell, if necessary, to help finance his mission.’

“President Kimball listened attentively as this statement was read to him, and then he responded: ‘Have him sell his stamp collection. Such sacrifice will be to him a blessing’” (“Profiles of Faith,” *Ensign*, Nov. 1978, 56).



**5.** Answer the following question in your scripture study journal: How would difficult decisions, like that Jose needed to make, be easier if we have already experienced the peace that results from obedience to the Lord’s commandments?

Read Doctrine and Covenants 19:36–41, looking for words or phrases that teach the following principle:

**If we do the will of the Lord, He will give us blessings that are of greater value than the treasures of the earth.**

What blessings of greater value than earthly treasures do you think Jose would receive by serving a mission? Read the conclusion of the story, and look for an additional blessing that Jose would receive for applying this principle:

“Then, with a twinkle in his eye and a smile on his face, this loving prophet [President Spencer W. Kimball] said, ‘Each month at Church headquarters we receive thousands of letters from all parts of the world. See that we save these stamps and provide them to Jose at the conclusion of his mission. He will have, without cost, the finest stamp collection of any young man in Mexico’” (“Profiles of Faith,” 56).

Ponder how the doctrines you have learned from this lesson could help strengthen your willingness to submit your will to God.

Martin Harris obeyed the command to sell his property for the printing of the Book of Mormon. Because of Martin’s choice, millions of lives have been and will continue to be blessed. Ponder what you can do to better submit your will to the will of Heavenly Father.



**6.** Write the following at the bottom of today’s assignments in your scripture study journal:

*I have studied Doctrine and Covenants 19:23–41 and completed this lesson on (date).*

*Additional questions, thoughts, and insights I would like to share with my teacher:*

## UNIT 6: DAY 1

# Doctrine and Covenants 20:1–36

## Introduction

“The Church of Christ in these last days [was] organized and established agreeable to the laws of [the United States of America]” on April 6, 1830 (D&C 20:1).

Among the early members of the Church, the revelation recorded in Doctrine and Covenants 20 was known as the “Articles and Covenants” of the Church because it reveals details regarding beliefs, offices, ordinances, and procedures of the newly restored Church. Along with Doctrine and Covenants 21–22, this section is often referred to as the “constitution” of the restored Church. Because of its length and content, Doctrine and Covenants 20 is divided into three lessons.

## Doctrine and Covenants 20:1–4

### *God commands that the Church be established*

Think about the last meeting you attended where testimonies were shared. If a friend who is not a member of the Church had attended the meeting with you and asked what a testimony is, how would you have explained it?



Consider the following definition of a testimony from Elder Dallin H. Oaks of the Quorum of the Twelve Apostles: “A testimony of the gospel is a personal witness borne to our souls by the Holy Ghost that certain facts of eternal significance are true and that we know them to be true” (“Testimony,” *Ensign* or *Liahona*, May 2008, 26).

Doctrine and Covenants 20 was read out loud at some of the early Church conferences and served as a reminder to the members of the Church of many important truths of the gospel of Jesus Christ. Read Doctrine and Covenants 20:1–2. Then complete the following principle by filling in the blanks: **Joseph Smith was \_\_\_\_\_ of God and commanded to organize \_\_\_\_\_.**

 **1.** Ponder your own testimony or feelings of the divine calling of Joseph Smith and the truthfulness of the church he was commanded to organize. In your scripture study journal, write about one or more experiences you have had that helped you receive a personal witness or progress toward receiving a personal witness of Joseph Smith’s role as prophet in restoring the Lord’s Church to the earth.

Notice that in Doctrine and Covenants 20:1, the Lord gave April 6, 1830, as the day His Church was organized.

## Doctrine and Covenants 20:5–16

### *A brief history of the events of the Restoration*

Doctrine and Covenants 20:5–6 refers to the first visit of the angel Moroni to Joseph Smith. Read Doctrine and Covenants 20:7–8, and identify what Moroni gave to Joseph Smith.

The Book of Mormon was published on March 26, 1830. The Church was organized within two weeks of its printing, on April 6, 1830. Why do you think it was important that the Book of Mormon be completed before the Church was organized? \_\_\_\_\_

\_\_\_\_\_

\_\_\_\_\_

Read Doctrine and Covenants 20:9–12, and mark phrases that tell how the Book of Mormon blesses the world.

 **2.** In your scripture study journal, complete the following phrases using what you learned in Doctrine and Covenants 20:9–12:

- The Book of Mormon proves to the world that angels still . . .
- The Book of Mormon proves to the world that the holy scriptures are . . .
- The Book of Mormon proves to the world that God does call and . . .
- The Book of Mormon shows to the world that God is . . .

These statements help us understand that **the Book of Mormon is evidence that God has restored the gospel in our day.** How could knowing this principle affect your desire to share the Book of Mormon with someone?

 **3.** Read Doctrine and Covenants 20:14–15, and mark what the Lord promised to those who receive the Book of Mormon and live by its teachings. Then answer the following questions in your scripture study journal:

- What blessing does the Lord promise to those who receive the Book of Mormon “in faith”?
- What are some ways a person could receive the Book of Mormon in faith?
- How can the Book of Mormon lead a person to “work righteousness”?

To help you consider how you have received the Book of Mormon in your life, circle the phrases in the following chart that best describe your experience with the Book of Mormon now:

Frequency	Quality
I read it every day.	I try my best to apply what I learn to my life.
I read it most days.	I sometimes apply what I learn to my life.
I read it occasionally, when I have time.	I usually don’t pay close attention to what I’m reading.
I never read it.	

What could you do to better receive the Book of Mormon “in faith” in your life?



## Doctrine and Covenants 20:17–36

*Important truths about the Godhead and the plan of salvation are taught*

What are the basic truths of the plan of salvation? What would you say if someone asked you to briefly explain the plan of salvation? Using only Doctrine and Covenants 20:17–29, you could give someone a brief explanation of the plan of salvation.

Read Doctrine and Covenants 20:17, 29–31, 35, and mark the phrase that is repeated near the beginning of each verse. Doctrine and Covenants 20:17–36 contains several important things the Lord’s Church declares to the world that we know to be true. Among these are truths concerning Heavenly Father, Jesus Christ, and the Holy Ghost and the things we must do to be saved in the kingdom of God.

 **4.** Read the scriptures referenced below, and then answer the questions in your scripture study journal:

- a. Doctrine and Covenants 20:17–19. What do we know about Heavenly Father?
- b. Doctrine and Covenants 20:21–25. What do we know about Jesus Christ?
- c. Doctrine and Covenants 20:25–26. What do we know about the infinite nature of the Atonement? (see also Mosiah 4:7).
- d. Doctrine and Covenants 20:26–28. What do we know about the Holy Ghost?

“We know” is an expression that complements Elder Oaks’s statement that “a testimony of the gospel is a personal witness borne to our souls by the Holy Ghost that certain facts of eternal significance are true and that we know them to be true” (“Testimony,” 26).

Several of the answers you wrote down in your scripture study journal might convey these truths: **God lives and is infinite, eternal, and unchanging** (verse 17). **We are created in the image and likeness of God** (verse 18). **God gave His Only Begotten Son to be crucified and rise again so that all who believe, are baptized, and endure in faith may be saved, including those who lived before the Savior was born** (verses 21–25). **The Holy Ghost testifies of the Father and the Son** (verse 27). **The Father, the Son, and the Holy Ghost work together to prepare us for eternal life** (verses 17–28).

 **5.** Select one of the preceding doctrines that is important to you and that you know or believe to be true. Imagine you had the opportunity to write a one-paragraph article in a major magazine or newspaper declaring what you know or believe to be true concerning that doctrine. In your scripture study journal, write which of these doctrines you would choose and what you would share and testify of concerning that truth.

See if you can unscramble the following words: tpneer, citusjfiniota, cantanotciifs, veol, reesv, dehe, ypar. These words emphasize the responsibility we have to show that we accept Heavenly Father and Jesus Christ. Read Doctrine and Covenants 20:29–34 to find the unscrambled words and complete the following statements:

- “All men must \_\_\_\_\_ and believe on the name of Jesus Christ.”
- \_\_\_\_\_ means to be forgiven and declared not guilty.
- \_\_\_\_\_ means to become holy, purified from the effects of sin, and Christlike.
- The Savior’s grace will help all those who \_\_\_\_\_ and \_\_\_\_\_ God.
- We need to take \_\_\_\_\_ and \_\_\_\_\_ always to withstand temptation.

What do these verses teach we must do to be saved in the kingdom of God?

Review the doctrines and principles highlighted in bold print throughout this lesson. Consider which of these truths you have personally come to know are true. As you review them, it may be helpful to place a check mark next to those truths you know are true.

 **6.** Write the following at the bottom of today’s assignments in your scripture study journal:

*I have studied Doctrine and Covenants 20:1–36 and completed this lesson on (date).*

*Additional questions, thoughts, and insights I would like to share with my teacher:*

**UNIT 6: DAY 2**

# Doctrine and Covenants 20:38–67

## Introduction

The organization of the Church on April 6, 1830, provided the means for priesthood ordinances to be administered to Heavenly Father’s children throughout the world in the latter days. Previous to the organization of the Church, the Lord began revealing the duties of offices in the priesthood to the Prophet Joseph Smith as early as the summer of 1829. Doctrine and Covenants 20 sets forth many of these duties and instructs priesthood holders in administering ordinances and watching over and ministering to the members of the Church.

## Doctrine and Covenants 20:38–59

*The duties of priesthood offices are set forth*

How would you answer if someone asked, “Who is the minister of your church?” As you study Doctrine and Covenants 20:38–67, think about how you would answer this question.

 **1.** Copy the following titles and references into your scripture study journal. Then read these scriptures, and list the duties of the priesthood offices under the appropriate heading in your journal. It may help you to know that the term “elder” in these verses refers to all Melchizedek Priesthood holders.

<i>Elders (D&amp;C 20:38–45)</i>	<i>Priests (D&amp;C 20:46–52)</i>	<i>Teachers and Deacons (D&amp;C 20:53–59)</i>

After you’ve written the duties under the appropriate headings, underline the differences you notice between the duties of an elder, a priest, a teacher, and a deacon. Circle the similarities.

Now that you have studied a little about priesthood duties, in the following chart, draw lines from the priesthood office to the duties those priesthood holders have the authority to perform:

Elder	Authority to bestow the gift of the Holy Ghost
Priest	Authority to administer (bless) the sacrament
Teacher	Authority to ordain a deacon
Deacon	Authority to teach

Answers to this matching activity are found at the end of this lesson. Notice that **the higher offices of the priesthood include the duties and authority of the lesser offices.**

 **2.** In your scripture study journal, write a principle that summarizes the responsibility of all priesthood holders.

Compare your principle with the following principle: **All priesthood holders have the responsibility to administer ordinances and to watch over members of the Church and minister to them.** You may want to write this truth in the margin of your scriptures near Doctrine and Covenants 20:38–59.



To help you understand more about the responsibility of all priesthood holders to watch over and minister to members of the Church, read Doctrine and Covenants 20:53–54, 59, and identify ways the Lord directed

priesthood holders to minister to and strengthen members of the Church. You may want to mark what you find. What are some ways that an Aaronic Priesthood holder can “watch over the church . . . and be with and strengthen them”? \_\_\_\_\_

The duties of Aaronic Priesthood holders go beyond administering ordinances. Ponder the following scenarios, and consider the ways the priesthood holders are performing their duty to invite others to come unto Christ and the ways they are not:

- After an Aaronic Priesthood holder helps in administering the sacrament in sacrament meeting, he goes to Sunday School and treats the teacher and other class members rudely.
- A young priesthood holder returns from home teaching and begins sharing sensitive or personal information about those he home taught.
- A group of priesthood holders meets for a service project and begins teasing and making fun of a fellow quorum member.

 **3. Answer the following question in your scripture study journal: Why is it important for priesthood holders to know that their duties include more than simply administering ordinances?**

You might want to write the following statement by Elder Richard G. Scott of the Quorum of the Twelve Apostles in the margin of your scriptures or in your scripture study journal: “The purpose of priesthood authority is to give, to serve, to lift, to inspire” (“Honor the Priesthood and Use It Well,” *Ensign* or *Liahona*, Nov. 2008, 46).

Think about when you have seen young men in your ward or branch honor their priesthood by watching over, serving, lifting, inspiring, or strengthening others. If you are a priesthood holder, consider writing a goal that will help you faithfully administer the ordinances and watch over and strengthen the Church.



## Doctrine and Covenants 20:60–67

*Guidelines on priesthood ordinations are given*

Have you experienced or seen a priesthood ordination? Think about the feelings you had as you were ordained or witnessed someone else being ordained.



Read Doctrine and Covenants 20:60, and identify the power the person performing the ordination should use in addition to the priesthood. According to this verse, what power should direct a priesthood holder as he exercises the priesthood? \_\_\_\_\_

How does a priesthood holder ensure that he performs his duties with this power? President Boyd K. Packer of the Quorum of the Twelve Apostles explained where a priesthood holder’s power comes from:



“Your authority comes through your ordination; your power comes through obedience and worthiness.

“Power in the priesthood comes from doing your duty in ordinary things: attending meetings, accepting assignments, reading the scriptures, keeping the Word of Wisdom.

“President Woodruff said: ‘I traveled thousands of miles and preached the Gospel as a Priest, and, as I have said to congregations before, the Lord sustained me and made manifest His power in the defense of my life as much while I held that office as He has done while I have held the office of an Apostle. The Lord sustains any man that holds a portion of the Priesthood, whether he is a Priest, an Elder, a Seventy, or an Apostle, if he magnifies his calling and does his duty’ ” (“The Unseen Power,” *New Era*, May 2007, 7; see also “The Aaronic Priesthood,” *Ensign*, Nov. 1981, 32–33).

If you are a young man, prayerfully consider what the Lord would have you do to invite the power of the Holy Ghost to accompany you as you perform your current and future priesthood duties. If you are a young woman, consider how you might help the young men in their efforts to obtain the Spirit in their lives and in their priesthood service.

Read Doctrine and Covenants 20:65. From what you learn in this verse, why do we raise our arms in Church to show a sustaining vote? The commandment for the Church to publicly offer a sustaining vote came from the Lord.

What does it mean to raise your arm and show a sustaining vote of another? Elder Loren C. Dunn, who was a member of the Seventy, explained the responsibilities that accompany the sustaining process:

“When we sustain officers, we are given the opportunity of sustaining those whom the Lord has already called by revelation. . . .

“The Lord, then, gives us the opportunity to sustain the action of a divine calling and in effect express ourselves if for any reason we may feel otherwise.

“To sustain is to make the action binding on ourselves and to commit ourselves to support those people whom we have sustained. When a person goes through the sacred act of raising his arm to the square, he should remember, with soberness, that which he has done and commence to act in harmony with his sustaining vote both in public and in private” (“We Are Called of God,” *Ensign*, July 1972, 43).

Have you ever been in a sacrament meeting when the congregation sustained a young man to be ordained to an office in the Aaronic Priesthood? Did the congregation raise their hands? How could a young man’s experience of seeing others sustain his ordination help him fulfill his responsibilities?



 **4.** In your scripture study journal, write a few sentences explaining why you are thankful for priesthood authority. Share what you have written with one of your parents or Church leaders, a sibling, or a friend. Ask that person to share with you his or her feelings about the meaning of the priesthood.

 **5.** Write the following at the bottom of today’s assignments in your scripture study journal:

*I have studied Doctrine and Covenants 20:38–67 and completed this lesson on (date).*

*Additional questions, thoughts, and insights I would like to share with my teacher:*

Answers to the matching activity:  
Elder: Authority to bestow the gift of the Holy Ghost  
Elder and priest: Authority to administer (bless) the sacrament  
Elder and priest: Authority to ordain a deacon  
Elder, priest, teacher, and deacon: Authority to teach

## UNIT 6: DAY 3

# Doctrine and Covenants 20:37, 68–84

## Introduction

The organization of the Church on April 6, 1830, made it possible for priesthood ordinances to be administered to Heavenly Father’s children throughout the world in the latter days. Previous to this long-awaited day, the Lord began revealing to the Prophet Joseph Smith the requirements and manner of baptism, what is expected of members of His Church, and the details of administering the sacrament.

## Doctrine and Covenants 20:37, 68–74

*The requirements and manner of baptism are set forth*

What would you say to a nonmember friend who asked, “What do I have to do to be baptized into your church?”

Read Doctrine and Covenants 20:37, and look for the requirements the Lord gave for those who desire to become members of the Church. You might want to mark each requirement you discover in the passage.

It might be helpful for you to know that to show forth a broken heart and a contrite spirit means to be humble and receptive to the will of God. It also means to feel deep sorrow for sin and a sincere desire to repent.





Elder D. Todd Christofferson of the Quorum of the Twelve Apostles explained: “In ancient times when people wanted to worship the Lord and seek His blessings, they often brought a gift. For example, when they went to the temple, they

brought a sacrifice to place on the altar. After His Atonement and Resurrection, the Savior said He would no longer accept burnt offerings of animals. The gift or sacrifice He will accept now is ‘a broken heart and a contrite spirit.’ [3 Nephi 9:20.] As you seek the blessing of conversion, you can offer the Lord the gift of your broken, or repentant, heart and your contrite, or obedient, spirit. In reality, it is the gift of yourself—what you are and what you are becoming” (“When Thou Art Converted,” *Ensign* or *Liahona*, May 2004, 12).

Why do you think these traits are required before a person gets baptized?

From what you learn in Doctrine and Covenants 20:37, complete the following principle: **When we are baptized we witness or demonstrate that** \_\_\_\_\_

Ponder how you are doing in living according to your baptismal covenants.

What would you say to your nonmember friend if he or she asked this additional question: “How are people baptized in your church?”

Read Doctrine and Covenants 20:72–74, and mark the manner of baptism described by the Lord. From these verses we learn that **baptism must be done by immersion and must be performed by one holding proper authority** (see also 3 Nephi 11:21–27).

How would you answer if your friend asked a third question: “What is required of people *after* they have been baptized and become members of your church?”

Read Doctrine and Covenants 20:68–69, and identify expectations the Lord has for each of us after we have been baptized. You may want to mark these expectations in your scriptures.

In Doctrine and Covenants 20:68 the Lord tells us that new members are to be taught by elders after baptism and before confirmation. In our day, the practice of teaching missionary lessons to investigators before baptism allows people to receive the gift of the Holy Ghost soon after their baptism.

From Doctrine and Covenants 20:69 we learn how we can manifest or show our worthiness after we are baptized. Using the Lord’s direction to us in that verse, complete the following principle: **After baptism, we show the Lord our worthiness through** \_\_\_\_\_



1. Answer the following questions in your scripture study journal:

- a. Why is it important that you remain worthy after you are baptized?
- b. What do you think it means to manifest or show “a godly walk and conversation”?



2. Read the section of *For the Strength of Youth* entitled “Language” ([2011], 20–21), and identify ways a young person might manifest “a godly walk and conversation.” Write in your scripture study journal about experiences when you have seen others do those things. How do you think their actions and attitudes affected the people around them?

Ponder how you will manifest “a godly walk and conversation” in the coming days.

## Doctrine and Covenants 20:75–79

### *The Lord gives instructions on administering the sacrament*

Have you ever had a friend who was not a member of the Church attend sacrament meeting with you? If so, how did you explain the ordinance of the sacrament? If you haven’t had this opportunity, what would you say to a friend to help him or her understand the sacrament?

Read Doctrine and Covenants 20:75, and identify what the Lord directed all Church members to do often.

In a later revelation the Lord explained, “It mattereth not what ye shall eat or what ye shall drink when ye partake of the sacrament, if it so be that ye do it with an eye single to my glory—remembering unto the Father my body which was laid down for you, and my blood which was shed for the remission of your sins” (D&C 27:2). Today we use water for the sacrament, “in remembrance of the blood of [Jesus Christ], which was shed for [us]” (D&C 20:79), instead of wine.



Why do you think we are directed to partake of the sacrament together often? Elder Melvin J. Ballard of the Quorum of the Twelve Apostles spoke about one particular blessing that comes from partaking of the sacrament weekly:

“We want every Latter-day Saint to come to the sacrament table because it is the place for self-investigation, for self-inspection, where we

may learn to rectify our course and to make right our own lives, bringing ourselves into harmony with the teachings of the Church and with our brethren and sisters. . . .

“ . . . The one thing that would make for the safety of every man and woman would be to appear at the sacrament table every Sabbath day. We would not get very far away in one week—not so far away that, by the process of self-investigation, we could not rectify the wrongs we may have done. . . . The road to the sacrament table is the path of safety for Latter-day Saints” (in Bryant S. Hinckley, *Sermons and Missionary Services of Melvin Joseph Ballard* [1949], 150–51).



Ponder why partaking of the sacrament weekly would be a protection to you.

 **3.** To learn why the sacrament is a path of safety for you, write the following two headings in your scripture study journal:

<i>When we partake of the sacrament, we witness that:</i>	<i>When we are faithful to the promises we make during the sacrament, the Lord promises that:</i>
---	---

Read Doctrine and Covenants 20:77–79, looking for what we witness or promise as we partake of the sacrament. Write what you find under the “When we partake of the sacrament . . .” heading in your journal. Then read the verses again, looking for what the Lord promises. Write what you find under the “When we are faithful . . .” heading in your journal.

Review the requirements of baptism you identified in Doctrine and Covenants 20:37. What similarities do you see in the covenant made at baptism and the promises made during the sacrament?

When you partake of the sacrament, you renew the covenant you made when you were baptized and confirmed.

 **4.** Answer the following questions in your scripture study journal:

- a. How can you show your willingness to take upon yourself the name of Jesus Christ?
- b. What are some things you can do to remember the Savior throughout the week? (see also Mosiah 18:8–10).
- c. How does partaking of the sacrament help you manifest “a godly walk and conversation” (D&C 20:69)?

Read the following statement about keeping and renewing our baptismal covenant: “You receive great blessings when you keep the baptismal covenant. As you renew it, the Lord renews the promised remission of your sins. Cleansed from sin, you are able to ‘always have his Spirit to be with [you]’ (D&C 20:77). The Spirit’s constant companionship is one of the greatest gifts you can receive in mortality. The Spirit will guide you in the paths of righteousness and peace, leading you to eternal life with your Father in Heaven and Jesus Christ” (*True to the Faith: A Gospel Reference* [2004], 148).

 **5.** In your scripture study journal, answer the following question: How can understanding the blessing of having the companionship of the Holy Ghost encourage us to honor our baptismal covenant?



Elder Dallin H. Oaks of the Quorum of the Twelve Apostles taught that we may enjoy the blessing of the ministering of angels as we renew our baptismal covenants by worthily partaking of the sacrament:

“Vital steps pertaining to the remission of sins are performed through the saving ordinance of baptism and the renewing ordinance of the sacrament. . . .

“ . . . These ordinances of the Aaronic Priesthood are also vital to the ministering of angels. . . .

“ . . . Angelic messages can be delivered by a voice or merely by thoughts or feelings communicated to the mind. . . .

“ . . . Most angelic communications are felt or heard rather than seen. . . .

“In general, the blessings of the spiritual companionship and communication are only available to those who are clean. . . . Through the Aaronic Priesthood ordinances of baptism and the sacrament, we are cleansed of our sins and promised that if we keep our covenants we will always have His Spirit to be with us. I believe that promise not only refers to the Holy Ghost but also to the ministering of angels, for ‘angels speak by the power of the Holy Ghost; wherefore, they speak the words of Christ’ (2 Nephi 32:3). So it is that those who hold the Aaronic Priesthood open the door for all Church members who worthily partake of the sacrament to enjoy the companionship of the Spirit of the Lord and the ministering of angels” (“The Aaronic Priesthood and the Sacrament,” *Ensign*, Nov. 1998, 38–39).

Ponder how you will prepare yourself to partake of the sacrament this week.

## Doctrine and Covenants 20:80–84

*Church membership records are to be kept accurately*

Doctrine and Covenants 20:81–84 contains the Lord’s instruction that elders in the early Church were to record the names of people who had joined the Church. They were told to bring these lists to Church conferences so they could be kept in a book. The names of those who had fallen away from the Church were removed. In addition, Church members moving from one location to another were to take a certificate of their membership with them to give to their new priesthood leader. In our day, Church leaders continue to keep accurate membership records, and the methods of doing so are more efficient.



**6.** Write the following at the bottom of today’s assignments in your scripture study journal:

*I have studied Doctrine and Covenants 20:37, 68–84 and completed this lesson on (date).*

*Additional questions, thoughts, and insights I would like to share with my teacher:*

## UNIT 6: DAY 4

# Doctrine and Covenants 21–23

## Introduction

The Church of Jesus Christ of Latter-day Saints was officially organized on April 6, 1830. Nearly 60 people attended the first worship service. The meeting consisted of prayers, sustainings, ordinations, the administration of the sacrament, and confirmations. During this meeting the Prophet Joseph Smith received the revelation now recorded in Doctrine and Covenants 21. A few days later the Lord clarified that baptism must be performed by those with proper priesthood authority (see D&C 22). He also gave personal counsel to five men who desired to know their duty (see D&C 23).

## Doctrine and Covenants 21

*The Lord designates Joseph Smith as the first prophet and seer in the restored Church of Jesus Christ*

Listen to or read the words to the hymn “We Thank Thee, O God, for a Prophet” (*Hymns*, no. 19). What are some reasons you feel thankful to God for a prophet? As you study today’s lesson, look for truths that can increase your gratitude for prophets.

Read Doctrine and Covenants 21:1, looking for the different titles by which Joseph Smith would be known. You may want to mark these in your scriptures or write them in your scripture study journal.



Elder John A. Widtsoe of the Quorum of the Twelve Apostles taught about the broad meaning of the title “prophet” and how it includes other titles:

“A prophet is a teacher. That is the essential meaning of the word. He teaches the body of truth, the gospel, revealed by the Lord to man; and under inspiration explains it to the understanding of the people. . . .

“In the sense that a prophet is a man who receives revelations from the Lord, the titles ‘seer and revelator’ merely amplify the larger and inclusive meaning of the title ‘prophet.’ . . .

“A seer is one who sees with spiritual eyes. He perceives the meaning of that which seems obscure to others; therefore he is an interpreter and clarifier of eternal truth. He foresees the future from the past and the present. This he does by the power of the Lord operating through him directly, or indirectly with the aid of divine instruments such as the Urim and Thummim. In short, he is one who sees, who walks in the Lord’s light with open eyes. [See Mosiah 8:15–17.]

“A revelator makes known, with the Lord’s help, something before unknown. It may be new or forgotten truth, or a new or forgotten application of known truth to man’s need. . . .

“In summary: A prophet is a teacher of known truth; a seer is a perceiver of hidden truth, a revelator is a bearer of new truth. In the widest sense, the one most commonly used, the title, prophet, includes the other titles and makes of the prophet, a teacher, perceiver, and bearer of truth” (*Evidences and Reconciliations*, arr. G. Homer Durham, 3 vols. in 1 [1960], 257–58).

In the Guide to the Scriptures, we learn that a prophet is “a person who has been called by and speaks for God. As a messenger of God, a prophet receives commandments, prophecies, and revelations from God. His responsibility is to make known God’s will and true character to mankind and to show the meaning of his dealings with them. A prophet denounces sin and foretells its consequences. He is a preacher of righteousness. On occasion, prophets may be inspired to foretell the future for the benefit of mankind. His primary responsibility, however, is to bear witness of Christ” (“Prophet,” scriptures.lds.org).

 **1.** Answer the following question in your scripture study journal: How do the titles given to Joseph Smith in Doctrine and Covenants 21:1 help you to understand the importance of his role and the various responsibilities he held in the restoration of the fulness of the gospel and the Church of Jesus Christ on the earth?

Read Doctrine and Covenants 21:2–3, looking for words or phrases indicating that **God inspired Joseph Smith to restore the Church of Jesus Christ**. You may want to mark these words or phrases in your scriptures.

 **2.** In your scripture study journal, explain why you think it is important to know that Joseph Smith was called by God to restore and lead the Church of Jesus Christ.

Read Doctrine and Covenants 21:4–5, and identify an important message the Lord revealed on the day the Church was organized.

 **3.** Answer the following question in your scripture study journal: Why may it sometimes require “patience and faith” to heed the words of a prophet?

President Wilford Woodruff gave assurance that we can always have faith in the Lord’s prophet: “The Lord will never permit me or any other man who stands as President of the Church to lead you astray. It is not in the programme. It is not in the mind of God. If I were to attempt that, the Lord would remove me out of my place” (*Teachings of Presidents of the Church: Wilford Woodruff* [2004], 199).



President Joseph F. Smith gave similar testimony: “If [the President of the Church] should become unfaithful, God would remove him out of his place. I testify in the name of Israel’s God that He will not suffer the head of the Church, him whom He has chosen to stand at the head, to transgress His Laws and apostatize; the moment he should take a course that would in time lead to it, God would take him away. Why? Because to suffer a wicked man to occupy that position, would be to allow, as it were, the fountain to become corrupted, which is something He will never permit” (*Teachings of Presidents of the Church: Joseph F. Smith* [1998], 227).

Read Doctrine and Covenants 21:6, and number in your scriptures the three blessings extended to those who receive the prophet’s word in patience and faith.

How would you summarize the promises given to those who heed the words of the prophet? (The following is one way to state the principle: **If we heed the words of the prophet, we will be protected against the adversary.**)

### Scripture Lists

Often the scriptures include lists of warnings, challenges, and blessings. When you find a list, you may want to number each element.

 **4.** In your scripture study journal, write about a time when you or someone you know was blessed for heeding the counsel and words of the living prophets. This could include following counsel given in general conferences and the *For the Strength of Youth* pamphlet.





President James E. Faust of the First Presidency spoke about the importance of sustaining the living prophet: “I do not believe members of this Church can be in full harmony with the Savior without sustaining His living prophet on the earth, the President of the Church. If we do not sustain the living prophet, whoever he may be, we die spiritually. Ironically, some have died spiritually by exclusively following prophets who have long been dead. Others equivocate in their support of living prophets, trying to lift themselves up by putting down the living prophets, however subtly” (“Continuing Revelation,” *Ensign*, Aug. 1996, 5).

Ponder what you must do to claim the blessings promised in Doctrine and Covenants 21:6.

## Doctrine and Covenants 22

*The Lord reveals that baptism must be performed by proper authority*

Some individuals who desired to join the Church in April 1830 had been baptized in other churches and wondered why they needed to be baptized again (see the section introduction to D&C 22). The Prophet Joseph Smith inquired of the Lord about the necessity of their being rebaptized. In His response, the Lord spoke about an important purpose for the Restoration of the gospel and the Church.

Read Doctrine and Covenants 22. What did the Lord say about why baptism by the proper authority is necessary?

In Doctrine and Covenants 22:1, the Lord spoke about “a new and an everlasting covenant.” In the following explanation, mark any words that may help you understand the meaning of this phrase:

The new and everlasting covenant is “the fulness of the gospel of Jesus Christ (D&C 66:2). It is new every time it is revealed anew following a period of apostasy. It is everlasting in the sense that it is God’s covenant and has been enjoyed in every gospel dispensation where people have been willing to receive it. The new and everlasting covenant was revealed again to men on earth by Jesus Christ through the Prophet Joseph Smith. It contains sacred ordinances administered by priesthood authority—such as baptism and temple marriage—that provide for man’s salvation, immortality, and eternal life” (Guide to the Scriptures, “New and Everlasting Covenant,” scriptures.lds.org).

When we understand these truths about the new and everlasting covenant, it is clear that **baptism must be performed by one having authority from God.**

Read Doctrine and Covenants 22:2–4, and identify phrases indicating that the Lord does not accept baptisms performed without the proper priesthood authority. It may be helpful to know that in verse 2 the Lord referred to the ordinance of baptism as entering “in at the strait gate” (see 2 Nephi 31:17).



**5.** The Church of Jesus Christ of Latter-day Saints has the priesthood authority necessary to perform essential ordinances such as baptism. Answer the following question in your scripture study journal: How have you been blessed by your membership in the restored Church of Jesus Christ?

## Doctrine and Covenants 23

*Five disciples are called to strengthen the Church*

Mark the following names in Doctrine and Covenants 23: Oliver, Hyrum, Samuel, Joseph, and Joseph Knight. Read the section introduction to learn what these men desired of the Lord.

The Lord first addressed Oliver Cowdery. Oliver was of great help to the Prophet Joseph Smith during the initial events of the Restoration, including the coming forth of the Book of Mormon and the organization of the Church. He had many gifts and righteous desires. He was called to be the second elder of the Church (see D&C 20:3) and was appointed, along with David Whitmer, to assist in selecting the Twelve Apostles. Unfortunately, Oliver allowed many of these early privileges to lead to pride, and he left the Church for a time. He eventually recognized his mistakes and was rebaptized.



**6.** Read Doctrine and Covenants 23:1–2, and look for a warning the Lord gave to Oliver Cowdery. Then answer the following questions in your scripture study journal:

- How can pride lead to temptation?
- In your opinion, what are some ways we can avoid feelings of pride that would lead us to temptation?

Read Doctrine and Covenants 23:3–5, looking for similarities in the instructions the Lord gave to Hyrum Smith, Samuel Smith, and Joseph Smith Sr.

The call to exhortation referred to the responsibility to teach the gospel to others. Notice how Hyrum, Samuel, and Joseph Smith Sr. each fulfilled this responsibility as you read the following information about them:

Hyrum Smith assisted in the publication of the Book of Mormon by working directly with the printer. He was baptized in June 1829, shortly after the priesthood had been restored. He served as president of the first branch of the Church in Colesville, New York. Known for his

humbleness and loyalty, Hyrum was faithful to the Lord and the Church throughout his life. He died as a martyr along with his brother Joseph in Carthage, Illinois.

Samuel Smith, a younger brother of the Prophet Joseph, was baptized in May 1829, shortly after the restoration of the Aaronic Priesthood. He is often credited with being the Church's first missionary. In June 1830 he left on a mission and placed a copy of the Book of Mormon that would eventually lead to the conversion of Brigham Young and many of his family members. Samuel was loyal to his family and the Church throughout his life.

Joseph Smith Sr., the Prophet's father, joined the Church the day it was organized. The following summer he and his son Don Carlos went on a mission to extended family in New York. He became a high priest and eventually the first patriarch of the Church. At his funeral he was described as "a man faithful to his God and to the Church in every situation and under all circumstances through which he was called to pass" (Robert B. Thompson, in *History of the Church*, 4:192).

The last person the Lord addressed in Doctrine and Covenants 23 is Joseph Knight Sr. He was a close friend of Joseph Smith Jr. and had shown him great kindness. He provided the Prophet with supplies, such as paper and food, during the translation of the Book of Mormon. At the time Doctrine and Covenants 23 was received, Joseph Knight Sr. had not been baptized. He had felt a desire to be baptized with others on the day the Church was organized, but refrained because he wanted to study the Book of Mormon further. However, he later wrote, "I should [have] felt better if I had gone forward" to be baptized (see Larry Porter, "The Joseph Knight Family," *Ensign*, Oct. 1978, 40; spelling and capitalization standardized).

Study the Lord's counsel to Joseph Knight Sr. in Doctrine and Covenants 23:6–7, looking for what the Lord commanded him to do. The phrase "take up your cross" in this context means to do something that is difficult for you.

 **7.** Answer the following questions in your scripture study journal:

- a. Why might the Lord sometimes direct us to do things we are not comfortable doing?
- b. What evidence do you see in Doctrine and Covenants 23:7 that the Lord desired to bless Joseph Knight Sr.?

A short time after this revelation was received, Joseph Knight Sr. chose to be baptized. He remained devoted to the Church throughout his life, defending the Prophet Joseph Smith privately and publicly. The Prophet later described Joseph Knight Sr. as "faithful and true, and even-handed and exemplary, and virtuous and kind, never deviating to the right hand or to the left" (*Teachings of Presidents of the Church: Joseph Smith* [2007], 462).

From Doctrine and Covenants 23, we learn that **as we desire to serve the Lord, we can receive personal guidance from Him**. We also learn that **the Lord will bless us as we follow the guidance He gives us**. Ponder the guidance you have received from the Lord through the Holy Ghost, the words of living prophets, and the scriptures. Make a plan to act on the guidance you have received.

 **8.** Write the following at the bottom of today's assignments in your scripture study journal:

*I have studied Doctrine and Covenants 21–23 and completed this lesson on (date).*

*Additional questions, thoughts, and insights I would like to share with my teacher:*

## UNIT 7: DAY 1

# Doctrine and Covenants 24–26

## Introduction

Persecution against the Prophet Joseph Smith and Church members had become intense by the summer of 1830. During this trying time the Lord strengthened and instructed Joseph Smith, Emma Smith, and other Church leaders through the revelations contained in Doctrine and Covenants 24–26.

## Doctrine and Covenants 24

*Joseph Smith and Oliver Cowdery receive counsel regarding their callings*

Think about one of the most difficult or frustrating days or weeks you have ever had. How did you deal with the difficulties you experienced?

The Prophet Joseph Smith experienced many difficult periods in his life. One such period was the summer of 1830. In June 1830, Joseph Smith and a few colleagues went to Colesville, New York, to visit people who were interested in being baptized. A stream was dammed to prepare for baptisms the next day (Sunday), but a hostile mob destroyed the dam during the night.

Early Monday morning, the dam was rebuilt and 13 people were baptized, including Emma Smith. By the time the baptisms were completed, however, a mob of nearly 50 men had gathered, insulting and threatening to harm the Saints.

That evening the Saints met to confirm those who had been baptized earlier that day, but before the confirmations could be performed, Joseph was arrested on charges of “being a disorderly person, of setting the country in an uproar by preaching the Book of Mormon” (Joseph Smith, in *History of the Church*, 1:88).

En route to his trial, Joseph escaped a mob with the help of the sympathetic constable. After standing trial and being acquitted of the charges, Joseph was immediately arrested again in a different county. That night Joseph was ridiculed and abused by “a number of men, who used every means to abuse, ridicule and insult” him (Joseph Smith, in *History of the Church*, 1:91). The next morning Joseph stood trial, and he was again acquitted of the charges and escaped another mob as he traveled home.

Joseph Smith and Oliver Cowdery made another attempt to unite with the recently baptized members in Colesville, but a mob gathered shortly after they arrived. Joseph and Oliver were forced to flee and barely escaped as the mob pursued them throughout the night.

Joseph said of this trying time, “Notwithstanding all the rage of our enemies, we had much consolation, and many things occurred to strengthen our faith and cheer our hearts” (in *History of the Church*, 1:101; for Joseph Smith’s account of these events in Colesville, see *History of the Church*, 1:86–97, 101).

Read the section heading of Doctrine and Covenants 24, looking for the purposes of the revelations contained in Doctrine and Covenants 24–26.



**1.** Complete both of the following exercises in your scripture study journal:

- Make two columns in your scripture study journal. Label the first column with the heading *Strengthen and Encourage*; label the second column with the heading *Instruct*. Study Doctrine and Covenants 24:1–12, and list phrases that could

strengthen and encourage or instruct Joseph and Oliver in the appropriate column.

- Select one phrase that is meaningful to you from one of the columns. Write two to three sentences explaining how that specific encouragement or instruction from the Lord might help someone going through a difficult experience.

One significant statement of encouragement and instruction from the Lord is found in Doctrine and Covenants 24:8. In your own words, write a principle taught in this verse: \_\_\_\_\_

An affliction is a cause or condition of pain, distress, or suffering. What do you think it means to “be patient in afflictions” and “endure them”? Being patient and enduring our afflictions is not always easy, but the Lord promises that He is with us throughout our afflictions.



**2.** Answer the following questions in your scripture study journal:

- When have you seen someone exercise patience and remain faithful while enduring afflictions?
- What did the person say or what did you see that showed the Lord was with this person?
- How can having faith that the Lord will be with you in times of trial help you have the courage and the strength to do hard things?

In Doctrine and Covenants 24:13–19 the Lord gave additional instruction to the Prophet Joseph Smith and Oliver Cowdery regarding how to fulfill their callings and what would happen to those who rejected and opposed them.

## Doctrine and Covenants 25

### *Emma Smith receives counsel regarding her family and Church duties*

As previously mentioned, Emma Smith was part of the group that was baptized in Colesville, New York, in June 1830, but due to mob persecution she was unable to be confirmed until early August (see *History of the Church*, 1:106, 108). Sometime between Emma’s baptism

### *Putting Your Name into the Scriptures*

Brigham Young once asked: “Do you read the Scriptures . . . as though you stood in the place of the men who wrote them? . . . It is your privilege to do so, that you may be as familiar with the spirit and meaning of the written word of God as you are with your daily walk and conversation” (*Teachings of Presidents of the Church: Brigham Young* [1997], 119).

and confirmation, the Prophet Joseph received the revelation in Doctrine and Covenants 25. In this revelation the Lord gave comfort and instruction for Emma, who would experience trials and make great sacrifices throughout her life.



Read Doctrine and Covenants 25. Then think about the comfort and counsel given to Emma in this revelation as you read the following details about her life:

Emma Hale Smith was raised in a prosperous home but, after marrying, often lived in very poor conditions. She acted as scribe while Joseph translated the gold plates during the early days of translation. Although she often saw the plates lying on the table, covered by a linen cloth, she never uncovered them to look at them.

Joseph and Emma's first three children died shortly after their birth. Throughout her life she would endure the deaths of five of her biological children and an adopted child. In addition, she and her husband would go through relentless persecution. Throughout their marriage Joseph and Emma were forced to leave their homes because of the threat of mobs. Emma's house

would be broken into; she would often have to move out of her own home and live with others, relying on their kindness for a temporary place to live; and eventually her beloved Joseph would be taken from her and murdered.

 **3.** The Lord told Emma Smith to "make a selection of sacred hymns . . . to be had in my church" (D&C 25:11). Review Doctrine and Covenants 25:12, and answer the following questions in your scripture study journal:

- a. What do you think the phrase "the song of the heart" means?
- b. How can "the song of the righteous" be like a prayer?
- c. Read the following statement:

"Music can enrich your life. It can edify and inspire you and help you draw closer to Heavenly Father. Music has a profound effect on your mind, spirit, and behavior.

"Choose carefully the music you listen to. Pay attention to how you feel when you are listening. Some music can carry evil and destructive messages. Do not listen to music that encourages immorality or glorifies violence through its lyrics, beat, or intensity. Do not listen to music that uses vulgar or offensive language or promotes evil practices. Such music can dull your spiritual sensitivity" (*For the Strength of Youth* [pamphlet, 2011], 22).

What can you do to surround yourself with worthy music?

 **4.** According to Doctrine and Covenants 25:16, the counsel and promises given to Emma Smith in this revelation also apply to each of us. Complete the following assignments in your scripture study journal:

- a. From what you read in Doctrine and Covenants 25, write at least four principles you learned from the counsel given to Emma. (For example, **if we keep God's commandments continually, we will receive a crown of righteousness** [verse 15], which is symbolic of receiving celestial glory in the kingdom of God.)
- b. Choose one of the principles you listed that you feel is applicable to you and write how you can apply this principle in your life now.

The Lord said that Emma Smith was "an elect lady" (D&C 25:3). The Prophet Joseph Smith later taught that "elect meant to be elected to a certain work" (in *History of the Church*, 4:552). Review Doctrine and Covenants 25, looking for what Emma Smith was elected (chosen, or called) to do at this time and what she would be "ordained" (given authority) to do (D&C 25:7).



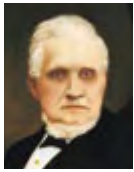

Nearly 12 years later, President John Taylor, acting under the direction of the Prophet Joseph Smith, set apart Emma to serve as the general Relief Society president of the Church. Recalling that experience, President Taylor said: “At that meeting the Prophet called Sister Emma to be an elect lady. That means that she was called to a certain work; and that was in fulfillment of a certain revelation [D&C 25] concerning her. She was elected to preside over the Relief Society, and she was ordained to expound the Scriptures. In compliance with [Brother] Joseph’s request I set her apart. . . . Sister Emma was elected to expound the Scriptures, and to preside over the Relief Society” (“Discourse by President John Taylor,” *Deseret News*, Mar. 9, 1881, 83).

Joseph Smith’s mother, Lucy Mack Smith, gave the following tribute to her daughter-in-law Emma: “I have never seen a woman in my life, who would endure every species of fatigue and hardship, from month to month, and from year to year, with that unflinching courage, zeal, and patience, which she has ever done; for I know that which she has had to endure—she has been tossed upon the ocean of uncertainty—she has breasted the storms of persecution, and buffeted the rage of men and devils, which would have borne down almost any other woman” (*History of Joseph Smith by His Mother*, ed. Preston Nibley [1958], 190–91).

 **5.** In your scripture study journal, write a short note of gratitude and admiration about a woman you know who has some of the qualities attributed to Emma Smith in Doctrine and Covenants 25 and Lucy Mack Smith’s statement. Consider giving a copy of your note to that woman.

### Scripture Mastery—D&C 25:13

Doctrine and Covenants 25:13 is a scripture mastery passage. You may want to mark it in a distinctive way so you can locate it easily later. The phrase “cleave unto the covenants” means to follow closely or cling to the covenants we have made with God. You may want to write this definition in the margin near that verse.

 **6.** In your scripture study journal, explain what Doctrine and Covenants 25:13 means to you.

To help you remember the Lord’s admonition to cleave unto the covenants we have made, write the words of Doctrine and Covenants 25:13 on a small piece of paper or card. Carry the paper with you for a few days, think about the words, and try to memorize them. You may want to recite and explain the meaning of this verse to a friend or family member once you have it memorized.

## Doctrine and Covenants 26

### *The Lord instructs Joseph Smith, Oliver Cowdery, and John Whitmer*

In Doctrine and Covenants 26:1 the Lord instructed Joseph Smith, Oliver Cowdery, and John Whitmer regarding the spiritual and physical labors they were to perform. The Lord then taught them an important principle about governing the Church.

Imagine that a friend of another faith is with you in a meeting when many Church officers are sustained in their callings (such as a ward or branch conference or a stake conference). Think about how you would explain the practice of sustaining the various Church officers to your friend.

Read Doctrine and Covenants 26:2, and look for a phrase relating to the practice of sustaining. You might want to mark the principle **all things are to be done by common consent in the Church**.

What do you think “common consent” means?

“Common consent” refers to the practice of Church members sustaining those called to serve in the Church, as well as sustaining other Church decisions requiring support of the membership. This is usually shown by raising the right hand.

There is a difference between sustaining by expressing common consent and voting. In the Lord’s kingdom, the Lord inspires His appointed leaders, who then make decisions by the authority He entrusts to them. The leaders then seek the Lord’s confirmation of their decisions. The raising of the right hand is not a way for members to cast a vote; it is a way to signify their consent (or opposition) to a decision that has already been made.

# Doctrine and Covenants 27

## Introduction

Emma Smith and 12 others, including Newel Knight and his wife, Sally, were baptized on June 28, 1830, in Colesville, New York. However, they were not confirmed then because a local mob disrupted the service and the Prophet Joseph Smith was arrested “on the charge of being a disorderly person, of setting the country in an uproar by preaching the Book of Mormon, etc.” (see *History of the Church*, 1:87–88). Joseph was cleared of all charges, but mobs still kept him away from Colesville until August 1830, when he was finally able to confirm most of the new converts. Joseph Smith then returned to his home in Harmony, Pennsylvania.

Early in August 1830, Newel Knight and his wife traveled to Harmony to visit Joseph and Emma Smith. Because Sally Knight and Emma had not yet been confirmed, it was decided that they would be confirmed and that those gathered would partake of the sacrament together. On his way to obtain some wine for the sacrament, the Prophet Joseph was met by a heavenly messenger and received the revelation in Doctrine and Covenants 27 (see *History of the Church*, 1:106).

## Doctrine and Covenants 27:1–4

### *The Lord gives instructions concerning the emblems of the sacrament*

What would you think if you saw potato peelings being used for the sacrament?



President Ezra Taft Benson visited war-torn Europe immediately following World War II. At that time food was scarce, and many people struggled just to survive. The scarcity of food made it necessary for Church members to adapt what they used as part of the sacrament. President Benson recalled: “I cannot forget the French Saints who, unable to obtain bread, used potato peelings for the emblems of the sacrament” (“Prepare for the Days of Tribulation,” *Ensign*, Nov. 1980, 33–34).



In addition to expressing their consent, or approval, when raising their right hand, members also signify their willingness to support the person or the action being presented. President Gordon B. Hinckley taught: “The procedure of sustaining is much more than a ritualistic raising of the hand. It is a commitment to uphold, to support, to assist those who have been selected” (“This Work Is Concerned with People,” *Ensign*, May 1995, 51).

Consider what you can do to better fulfill your commitment to support someone who has been called and sustained to serve you in your ward or branch.



**7.** Write the following at the bottom of today's assignments in your scripture study journal:

*I have studied Doctrine and Covenants 24–26 and completed this lesson on (date).*

*Additional questions, thoughts, and insights I would like to share with my teacher:*



1. Read Doctrine and Covenants 27:1–2, and identify what the angel told Joseph Smith about the emblems of the sacrament. In your scripture study journal, answer the following questions:

- a. Why do you think it was acceptable in the circumstance of the French Saints to use something other than bread as emblems of the sacrament?
- b. According to Doctrine and Covenants 27:2, what should be our focus as we partake of the sacrament?

Complete the following principle by filling in the blanks: **As we partake of the \_\_\_\_\_, we are to \_\_\_\_\_ the atoning sacrifice of Jesus Christ.**



2. Answer the following questions in your scripture study journal:

- a. What do you think partaking of the sacrament “with an eye single to [God’s] glory” means?
- b. How can you more fully remember the Savior’s Atonement as you partake of the sacrament?

In Doctrine and Covenants 27:3–4 the Lord warned Joseph Smith not to use wine or strong drink (any drink with intoxicating qualities) for the sacrament if it was purchased from their enemies. Only wine that was made by the Saints could be used (this was more than two years before the Word of Wisdom [D&C 89] would be revealed). Today, water is used in the sacrament instead of wine.

## Doctrine and Covenants 27:5–14

*The Lord will partake of the sacrament again on the earth*

Ponder how your experience taking the sacrament might be different if you were doing so in the presence of the Savior.

When the Savior introduced the ordinance of the sacrament to His Apostles at the Last Supper, He prophesied of a time when He would return to the earth and partake of the sacrament again with His disciples (see Matthew 26:26–29).

Throughout history the Lord has given priesthood authority to righteous men to help administer the ordinances of His gospel. He has also given priesthood keys to priesthood leaders so they can direct, control, and govern the use of His priesthood on earth.



3. In Doctrine and Covenants 27:5–12 we learn about some of those who will attend this sacrament meeting with Jesus Christ. Read these verses, and in your scripture study journal, make a list of the individuals who will attend this meeting and, if mentioned, what keys or responsibility they have.

Read Doctrine and Covenants 27:13, and identify what keys the Lord gave to the Prophet Joseph Smith. You may want to mark the phrase “dispensation of the gospel for the last times; and for the fulness of times.” From this verse we learn that **the dispensation of the fulness of times brings together all gospel keys, ordinances, and truths of past dispensations.**

A dispensation is a period of time when the Lord reveals His gospel doctrines, ordinances, and priesthood. It is a period “in which the Lord has at least one authorized servant on the earth who bears the holy priesthood and the keys, and who has a divine commission to dispense the gospel to the inhabitants of the earth. When this occurs, the gospel is revealed anew, so that people of that dispensation do not have to depend basically on past dispensations of knowledge of the plan of salvation” (Bible Dictionary, “Dispensations”).

Our dispensation is the final dispensation. It is often called “the dispensation of the fulness of times” because all of the priesthood keys that the Lord has revealed for the blessing of His children have been restored (see Ephesians 1:10). The Prophet Joseph Smith is the head, or leader, of this gospel dispensation, just like Adam, Enoch, Noah, and Moses were heads of other gospel dispensations.

Read Doctrine and Covenants 27:14, and identify who else will be present at the sacrament meeting with the Savior.

Who do you think the Savior meant by “all those whom my Father hath given me out of the world”?



Elder Bruce R. McConkie stated: “Every faithful person in the whole history of the world, every person who has so lived as to merit eternal life in the kingdom of the Father will be in attendance and will partake, with the Lord, of the sacrament” (*The Promised Messiah: The First Coming of Christ* [1978], 595).



4. Write your name under the list of those whose names you have already written in your scripture study journal. Then answer the following question: How do you feel, knowing that you could be in attendance at this sacrament meeting with the Lord?

## Doctrine and Covenants 27:15–18

*The Lord commands His people to put on the whole armor of God*

Doctrine and Covenants 27:15–18 contains counsel that will help us be worthy to qualify for the Lord’s blessings, including the blessing of attending the sacrament meeting mentioned in verses 4–14.

What would you want to wear if you knew you were going into battle?

 **5.** Read Doctrine and Covenants 27:15, and answer the following questions in your scripture study journal:

- a. What did the Lord counsel us to do to prepare for our spiritual battles?
- b. The Lord promised that **if we take upon ourselves the whole armor of God, we will be able to withstand the evil day.** What do you think “the evil day” refers to? What do you think it means “to stand” at that time?

Study Doctrine and Covenants 27:15–18, and label each piece of armor in the accompanying diagram with words or phrases from those verses.



 **6.** Answer the following questions in your scripture study journal:

- a. Why do you think the Lord invites us to put on the *whole* armor of God?
- b. How can the attributes associated with each piece of armor protect us against temptation and evil?
- c. In what ways have you felt protection in your life as you have sought to put on the armor of God?

Ponder what you could do to more fully put on the whole armor of God by considering what areas in your life you need to improve.

 **7.** Write the following at the bottom of today’s assignments in your scripture study journal:

*I have studied Doctrine and Covenants 27 and completed this lesson on (date).*

*Additional questions, thoughts, and insights I would like to share with my teacher:*

### UNIT 7: DAY 3

# Doctrine and Covenants 28

## Introduction

Between April and September of 1830, some Church members misunderstood the principles that govern revelation in the Church. These misunderstandings produced challenges for the Prophet Joseph Smith. In the revelation contained in Doctrine and Covenants 28, the Lord revealed truths that provided solutions to these challenges.

## Doctrine and Covenants 28:1–7

*The Lord explains that revelation to govern His Church is given through His appointed prophet*

There are many examples in the world of things that are merely imitations of things that are authentic, real, and better. When might it be harmful to mistake an imitation for something that is real?





Spiritual imitations are a significant danger. Elder Dallin H. Oaks of the Quorum of the Twelve Apostles warned: “The devil is the father of lies, and he is ever anxious to frustrate the work of God by his clever imitations” (“Two Lines of Communication,” *Ensign* or *Liahona*, Nov. 2010, 84).

Read the section introduction to Doctrine and Covenants 28 in your scriptures. As you read, look for an imitation Satan used to deceive some early members of the Church. You may want to mark what you find.

Because of the seeming similarities between Hiram Page’s claims of receiving revelation through a stone and the way they thought God revealed truth to the Prophet Joseph Smith, Church members, including Oliver Cowdery, may have been more likely to believe in the false revelations Satan conveyed to Hiram Page. As you study the Lord’s words to Oliver in Doctrine and Covenants 28, look for important truths that can help prevent you from being misled by Satan’s imitations or counterfeits.

Read Doctrine and Covenants 28:1–5. One important truth we learn is that **the President of the Church is the only person who can receive revelation for the whole Church.** You may want to write this principle in the margin of your scriptures near these verses.



**1.** In your scripture study journal, answer the following questions:

- a. How can knowing this principle help Church members avoid being deceived?
- b. What were the differences between Oliver Cowdery’s responsibilities as second elder in the Church and Joseph Smith’s responsibilities as President of the Church?

Not long before the Lord gave the revelation in Doctrine and Covenants 28, something happened that illustrates how Oliver Cowdery did not yet fully understand the differences between his responsibilities in the Church and the role of Joseph Smith as the prophet and President of the Church.

While living in Harmony, Pennsylvania, Joseph Smith received a letter from Oliver Cowdery, who was in Fayette, New York. The Prophet recorded:



“He wrote to inform me that he had discovered an error in one of the commandments [in the revelation that is now found in section 20 of the Doctrine and Covenants], and added: ‘I command you in the name of God to erase those words, that no priestcraft be amongst us!’

“I immediately wrote to him in reply, in which I asked him by what authority he took upon him to command me to alter or erase, to add to or diminish from, a revelation or commandment from Almighty God.

“A few days afterwards I visited him and Mr. Whitmer’s family, when I found the family in general opinion concerning the words . . . , and it was not without both labor and perseverance that I could prevail with any of them to reason calmly on the subject. However, . . . finally, . . . I succeeded in bringing not only the Whitmer family, but also Oliver Cowdery to acknowledge that they had been in error” (in *History of the Church*, 1:105).

Read Doctrine and Covenants 28:6–7, and identify the Lord’s direction to Oliver Cowdery. Verse 6 helps us understand that **in the Church of Jesus Christ, individual members do not receive revelation to direct someone who presides over them.**

The Prophet Joseph Smith taught: “It is contrary to the economy of God for any member of the Church, or any one, to receive instructions for those in authority, higher than themselves; therefore you will see the impropriety of giving heed to them; but if any person have a vision or a visitation from a heavenly messenger, it must be for his own benefit and instruction; for the fundamental principles, government, and doctrine of the Church are vested in the keys of the kingdom” (*Teachings of Presidents of the Church: Joseph Smith* [2007], 197–98).



**2.** Answer the following question in your scripture study journal: How can understanding and following the principles governing receiving revelation in the Church help us support and sustain our Church leaders?

## Doctrine and Covenants 28:8–10

*The Lord calls Oliver Cowdery to preach the gospel to the Lamanites*

Look at the roles and callings listed below, and circle those that you think individuals have the right to receive revelation to help them in their responsibilities.

Parent	General Authority	Home or visiting teacher	Bishop or branch president
Sunday School teacher	Missionary	Mia Maid or teachers quorum president	Relief Society president

We can learn who has the right to receive revelation to help them in their responsibilities from what the Lord told Oliver Cowdery in Doctrine and Covenants 28:8–10. Read these verses, and identify what the Lord called Oliver to do.

In the Book of Mormon, the term *Lamanites* refers to a specific group of people, some of whom were descendants of Laman, the eldest son of Lehi. The term *Lamanites* in Doctrine and Covenants 28:8 refers to the Native Americans living on the western border of the United States, some of whom may have been descendants of that Book of Mormon people.

Mark the promise and counsel the Lord gave Oliver in Doctrine and Covenants 28:8 that would help us know who has the right to receive revelation to help them in their responsibilities.

The Lord told Oliver Cowdery that he could receive revelation to help him in his missionary labors. Doctrine and Covenants 28:8 helps us understand that **we may receive revelation for our own benefit and to help us in the callings and assignments we are given.**

You could have circled each of the roles and callings listed at the beginning of this section because each of those individuals has the right to receive revelation for their respective responsibilities. For whom do you think it would be helpful for these individuals to receive revelation? How could receiving revelation for those they have responsibilities for help them?

Think about how revelation may help you in your personal life or in a Church calling or assignment you have.



President Boyd K. Packer of the Quorum of the Twelve Apostles warned that personal revelation does not qualify a person to receive revelation to direct someone who presides over him or her and gave counsel about personal revelation:

“Revelation comes in an orderly way in the Church. We are entitled to personal revelation. However, unless we are set apart to some presiding office, we will not receive revelations concerning what others should do.

“Revelation in the Church comes to those who have been properly called, sustained, ordained, or set apart. . . .

“An unusual spiritual experience should not be regarded as a personal call to direct others. It is my conviction that experiences of a special, sacred nature are individual and should be kept to oneself.

“Few things disturb the channels of revelation quite so effectively as those who are misled and think themselves to be chosen to instruct others when they are not chosen” (“Revelation in a Changing World,” *Ensign*, Nov. 1989, 14–15).

## Doctrine and Covenants 28:11–16

*The Lord directs Oliver Cowdery to correct Hiram Page and help settle the Church*

Review the section heading to Doctrine and Covenants 28. Then read the Lord’s instructions to Oliver Cowdery in Doctrine and Covenants 28:11–14. What was Oliver commanded to do to help resolve the problem with Hiram Page?

From Doctrine and Covenants 28:11–14 we learn that **Church leaders have the responsibility to correct those who are leading others astray.** Notice the phrase “thou shalt take thy brother, Hiram Page, between him and thee alone” (D&C 28:11). This teaches that correction should be done privately and carefully.

Doctrine and Covenants 28:13 also teaches that **in the Church of Jesus Christ, all things must be done in order.**

Read Doctrine and Covenants 28:15–16 to learn the Lord’s concluding counsel to Oliver Cowdery. Soon after the Prophet Joseph Smith received the revelation in Doctrine and Covenants 28, a conference was convened. Joseph Smith wrote, “The subject of the stone previously mentioned was discussed, and after considerable investigation, Brother [Hiram] Page, as well as the whole Church who were present,

renounced the said stone, and all things connected therewith, much to our mutual satisfaction and happiness” (in *History of the Church*, 1:115).

 **3.** To help you apply the principles and doctrines taught in Doctrine and Covenants 28, read each of the following scenarios, and then, in your scripture study journal, write one of the bolded truths from today’s lesson that you feel best applies. The first one is answered for you as an example.

**a.** You are preparing to speak in sacrament meeting and have found many scriptures, quotations, and stories you could include in your talk. You aren’t sure which ones to use or what you should say.

Principle: **We may receive revelation for our own benefit and to help us in the callings and assignments we are given.**

**b.** You receive an email message that claims to have information about the Second Coming of Jesus Christ. However, the information is not in harmony with the teachings of the living prophet.

**c.** A friend is upset with her bishop, who has just called a new president of the Young Women in her ward. Your friend feels a different sister should have been called.

**d.** Your older sister has been dating a member of the Church. He told her that, as a priesthood holder, he received revelation that she should marry him. However, she has prayed about this decision and has not received a clear answer but has felt unsettled and pressured.

 **4.** Write the following at the bottom of today’s assignments in your scripture study journal:

*I have studied Doctrine and Covenants 28 and completed this lesson on (date).*

*Additional questions, thoughts, and insights I would like to share with my teacher:*

## UNIT 7: DAY 4

# Doctrine and Covenants 29:1–30

### Introduction

Shortly before a Church conference on September 26, 1830, the Lord gave the revelation found in Doctrine and Covenants 29 “in the presence of six elders” (D&C 29, section heading). The instructions in this revelation apply to all those who are called to declare the gospel.

## Doctrine and Covenants 29:1–5

*The Lord testifies of His Atonement and His desire to gather His people*

Have you ever wondered whether God would love, protect, and forgive you? Read Doctrine and Covenants 29:1–5, looking for how the Savior loves, protects, and forgives.

According to Doctrine and Covenants 29:2, what did the Savior compare Himself to?

When a hen senses danger, she will call to her chicks. They will come to her, and she will gather them under her outstretched wings to protect them. She will sacrifice herself to save her chicks.



Consider what the chicks must do in order to be safely gathered under the protection of the mother hen. What could happen to the chicks if they did not do what they needed to do? How is Jesus Christ like a hen gathering and protecting her chicks?

Review Doctrine and Covenants 29:2, and think about what we need to do to be gathered to Jesus Christ for safety. Mark words or phrases in verses 1–2 that teach this truth: **Jesus Christ will gather us in His arms of mercy if we hearken to His voice, are humble, and call on His name in prayer.** (Remember that the word *hearken* means to listen attentively and obey.)

 **1.** In your scripture study journal, answer the following questions:

- a.** What are you doing to hearken to the Lord’s voice now in your life? What more could you be doing?
- b.** When have you felt closer to the Savior by hearkening to His voice or through prayer?



Doctrine and Covenants 29:5 begins with the phrase “lift up your hearts and be glad.” (You may want to mark this phrase in your scriptures.) Why did the Lord say they should be glad? What we can learn from Doctrine and Covenants 29:1–5 about why we can lift up our hearts and be glad?

One principle we can learn is that **because Jesus Christ atoned for our sins and is our Advocate with the Father, we can lift up our hearts and be glad.** You might want to write this truth in the margin of your scriptures next to verse 5.

 **2.** In your scripture study journal, write about how the Atonement of Jesus Christ has brought happiness and joy to your life or the life of someone you know.

## Doctrine and Covenants 29:6–13

*Jesus Christ will gather His elect in preparation for His Second Coming*

After we have received a testimony of the Atonement of Jesus Christ, we have a responsibility to share the news of it with others. Read Doctrine and Covenants 29:7–8, looking for whom the Lord wanted these elders to gather through their preaching of the gospel. What did the Lord say about His elect in verse 7?

 **3.** Answer the following question in your scripture study journal: From what you have learned about the Lord’s elect, what are you doing in your life to be one of the elect of God?

In Doctrine and Covenants 29:10–13 the Savior taught that He will “reveal [Himself] from heaven with power and great glory” (verse 11), or in other words, He will come from heaven to earth again, and He will reign

in righteousness for 1,000 years. When He comes again, with His Apostles standing at His “right hand” (verse 12), He will judge the people of the earth, and the righteous who have died will be resurrected.

## Doctrine and Covenants 29:14–21

*The Lord describes the signs that will precede the Second Coming*

Although no person on earth knows the exact time of the Second Coming, the Lord has told us of signs that will occur before the Second Coming so the righteous can be prepared. Read Doctrine and Covenants 29:14–21, and mark some of the events that will happen before the Second Coming.

 **4.** In your scripture study journal, describe how knowing the signs of the Second Coming can help us stay faithful.

Remembering the analogy of the hen calling her chicks will help you understand the Savior’s message in these verses. Reread Doctrine and Covenants 29:17, and identify what will happen to those who do not respond when the Savior calls.

In Doctrine and Covenants 29:17 we learn the principle that **if we do not repent, the Savior’s atoning blood will not cleanse us.**

Ponder if there is anything in your life that you need to repent of and what you must do to be cleansed.

## Doctrine and Covenants 29:22–30

*The Millennium and the Final Judgment*

After teaching about the Second Coming, the Lord taught the Saints about what would happen after the Millennium. The Millennium is the 1,000-year period of peace that will begin when Christ returns to reign personally on the earth. Read Doctrine and Covenants 29:22–30, and identify what will happen after the Millennium. (It may help you to know that Michael, the archangel mentioned in verse 26, is Adam [see D&C 107:54].)

Consider how knowing these truths could have helped early missionaries better fulfill their callings to preach the gospel and gather the elect.

Read Doctrine and Covenants 29:27 again, looking for the blessing given to those who are gathered to the Savior. You might want to mark words or phrases that teach this principle: **Those who have lived righteously and come unto Jesus Christ will receive eternal life.**



 **5.** Consider where you stand in your efforts to come unto Jesus Christ. What can you do today to draw nearer to Him? Write your plan in your scripture study journal.

 **6.** Write the following at the bottom of today's assignments in your scripture study journal:

*I have studied Doctrine and Covenants 29:1–30 and completed this lesson on (date).*

*Additional questions, thoughts, and insights I would like to share with my teacher:*

## UNIT 8: DAY 1

# Doctrine and Covenants 29:31–50

### Introduction

Shortly before a Church conference on September 26, 1830, the Lord gave the revelation found in Doctrine and Covenants 29 “in the presence of six elders” (D&C 29, section heading). When you studied Doctrine and Covenants 29:1–30 during an earlier lesson, you learned about the gathering of the Lord’s elect and the building up of Zion. This lesson focuses on the nature of the Fall of Adam as revealed in Doctrine and Covenants 29:31–50.

### Doctrine and Covenants 29:31–35

*The Savior explains that all things are spiritual to Him*

Ponder how you would respond in the following situations:

**Situation 1:** Imagine one of your friends is participating in inappropriate behavior that you know is harmful to him. On one occasion you try to encourage your friend to stop this behavior, but he tells you his choices aren’t a big deal because nothing bad has happened to him. What principles of the gospel could help your friend understand the importance of his choices?

**Situation 2:** Imagine one of your friends comes to you and says she is feeling a little discouraged. She tells you she doesn’t know if keeping the commandments is worth the effort. She explains that even though she has tried to do what God has commanded, she doesn’t see

her circumstances as being any better than those of her peers who choose to sin. What principles of the gospel could help your friend continue to be obedient?

As you study the last part of Doctrine and Covenants 29, look for doctrines and principles that could be used to help individuals in these situations.

In 1830 the Church of Jesus Christ was restored and organized once again on the earth, and the fulness of the gospel was being revealed to the members of the Church through the Prophet Joseph Smith. In the revelation recorded in Doctrine and Covenants 29, the Lord helped the early Saints understand more about the Fall of Adam and revealed some of the purposes of His commandments.

Doctrine and Covenants 29:31–33 teaches that God created all things spiritually. One meaning of this is that they could exist in His presence and were not subject to death. He prepared a way for His creations to become temporal, meaning they would be separated from His presence and subject to death. God also made a way for His creations to overcome death and return to His presence. This is all part of His plan to give His children the opportunity to become like Him.

Read Doctrine and Covenants 29:34–35, looking for how the Lord views the commandments He gives to us. Mark this truth in your scriptures: **All of God’s commandments are spiritual.** Each commandment God gives has a spiritual purpose and is intended to help us return to His presence.

 **1.** As an example of the doctrine that all of God’s commandments are spiritual, consider the Word of Wisdom. In your scripture study journal, answer the following questions:

- How might obedience to the Word of Wisdom affect us physically?
- How might obedience to the Word of Wisdom affect us spiritually?

There may be physical consequences resulting from not obeying the Word of Wisdom, but the greatest consequences are spiritual in nature, especially to members of the Church who have covenanted to obey that commandment. Because all commandments from God are spiritual, including the Word of Wisdom, obedience brings spiritual blessings into our lives. On the other hand, disobedience to God’s commandments keeps us from receiving or causes us to lose spiritual blessings.



Ponder how knowing that God’s commandments are all spiritual could help the individuals in the situations you read about at the beginning of this lesson.

### Doctrine and Covenants 29:36–41

#### *Adam’s Fall brought about spiritual death*

While God gives us commandments to bless us spiritually, notice in Doctrine and Covenants 29:35 that He allows us to be agents unto ourselves. This means God gives all of His children agency and allows them to choose if they will obey His commandments.

 **2.** Draw the following chart in your scripture study journal. Then read Doctrine and Covenants 29:36–41, and fill in the choices and consequences of the people or groups of people:

	<i>Choices</i>	<i>Consequences</i>
<i>The devil</i>	⇒	⇒
<i>“A third part of the hosts of heaven”</i>	⇒	⇒
<i>Adam</i>	⇒	⇒

Consider writing the following principle in your scriptures: **God has given us the gift of agency to make choices and receive the consequences of those choices.**

Before Adam ate the forbidden fruit, he lived on the earth in the Garden of Eden and could dwell in God’s presence. After he ate the fruit, he remained on the earth but could no longer remain in God’s presence. Because Adam yielded to temptation and ate the forbidden fruit, all of us are in a temporal condition (subject to death) and separated from the presence of God. According to Doctrine and Covenants 29:41, what is this separation called?

 **3.** In your scripture study journal, draw the following diagram:

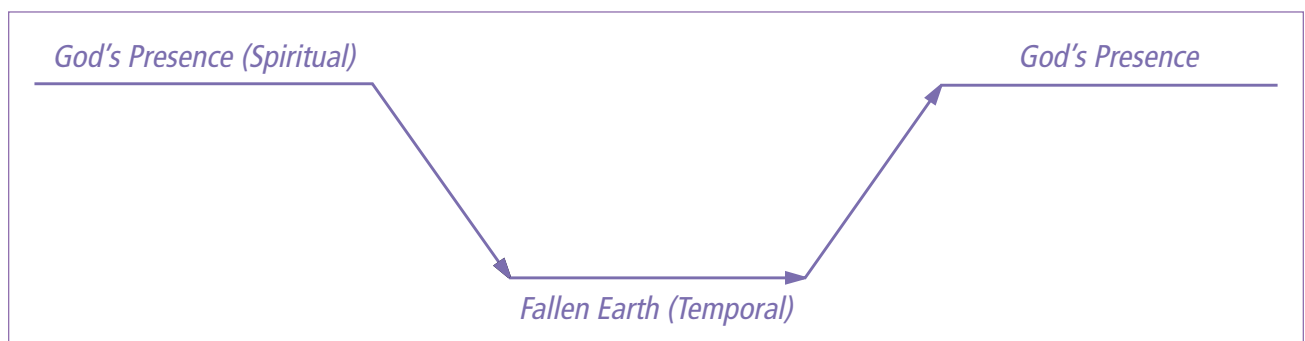

On the diagram, under the phrase “Fallen Earth (Temporal),” write: *Spiritual death is being cast out from God’s presence.* Then answer the following question: Why do you think it is necessary for us to be separated from God’s presence for a time?

Read the following statement about the Fall and why we must be separated from God for a time: “The Fall is an integral part of Heavenly Father’s plan of salvation (see 2 Nephi 2:15–16; 9:6). It has a twofold direction—downward yet forward. In addition to introducing physical and spiritual death, it gave us the opportunity to be born on the earth and to learn and progress” (*True to the Faith: A Gospel Reference* [2004], 57; see also 2 Nephi 2:25).



Elder Bruce R. McConkie of the Quorum of the Twelve Apostles taught the following about the Fall:

“The most important events that ever have or will occur in all eternity . . . are the Creation, the Fall, and the Atonement.

“Before we can even begin to understand the temporal creation of all things, we must know how and in what manner these three eternal verities—the Creation, the Fall, and the Atonement—are inseparably woven together to form one plan of salvation. No one of them stands alone; each of them ties into the other two; and without a knowledge of all of them, it is not possible to know the truth about any one of them. . . .

“. . . Be it remembered, the Atonement came because of the Fall. Christ paid the ransom for Adam’s transgression. If there had been no Fall, there would be no Atonement with its consequent immortality and eternal life. Thus, just as surely as salvation comes because of the Atonement, so also salvation comes because of the Fall.

“Mortality and procreation and death all had their beginnings with the Fall” (“Christ and the Creation,” *Ensign*, June 1982, 9).

## Doctrine and Covenants 29:42–50

*The Atonement of Jesus Christ redeems us from spiritual death*

Ponder the following question: Who will return to God’s presence?

To understand the Lord’s teachings in Doctrine and Covenants 29, it is important to know that all people will return to God’s presence after they are resurrected. This is because the Atonement of Jesus Christ redeems all mankind from the physical and spiritual effects of the Fall (see Helaman 14:15–18).

 4. In your scripture study journal, on the right side of the diagram, under the phrase “God’s Presence,” write: *Through the Atonement, all mankind will be redeemed from physical and spiritual death caused by the Fall of Adam.* Then answer the following question: If all of us will eventually be brought back into God’s presence, why do you think it matters whether or not we make good choices here on earth?



Through His Atonement, Jesus Christ offers forgiveness and eternal life to all those who exercise faith in Him and repent of their sins. Read Doctrine and Covenants 29:42–43, and look for what we must do to be worthy to remain in God’s presence. Ponder what things you might need to repent of so you can qualify to remain in God’s presence someday.

Although all mankind will be resurrected and will be redeemed from spiritual death and brought back into God’s presence to be judged, not everyone will remain there.

 5. In your scripture study journal, on the right side of the diagram, draw a dotted line with an arrow pointing away from the presence of God. Then read Doctrine and Covenants 29:44–45, and answer the following questions:

- a. What choices cause people to be unworthy to remain in God’s presence?
- b. What are the consequences of their choices?

 6. In your scripture study journal, next to the dotted line on the diagram, write: *Those who do not exercise faith or repent cannot remain eternally in God’s presence.*

The following shows how your diagram should look in your scripture study journal:

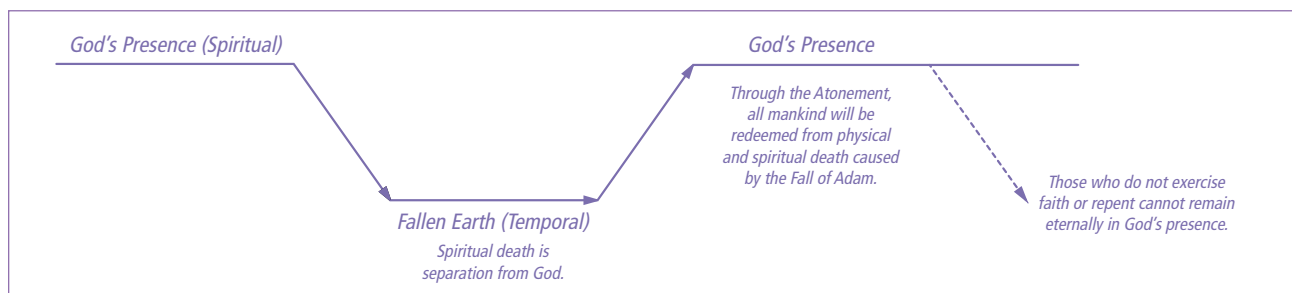

 **7.** Review the two situations described at the beginning of this lesson. Then answer the following questions in your scripture study journal:

- a. What did you learn today that could help the friend in situation 1?
- b. What did you learn today that could help the friend in situation 2?

Read Doctrine and Covenants 29:49, and think about the Lord’s expectations for you. Make a goal to continue to apply the Atonement of Jesus Christ in your life by repenting of your sins and preparing yourself to live in God’s presence once again.

 **8.** Write the following at the bottom of today’s assignments in your scripture study journal:

*I have studied Doctrine and Covenants 29:31–50 and completed this lesson on (date).*

*Additional questions, thoughts, and insights I would like to share with my teacher:*

the Lord called Parley P. Pratt and Ziba Peterson to take part in a mission to the Lamanites. As you study these sections, notice the counsel and promises the Lord gave to these missionaries.

### Doctrine and Covenants 30

*The Lord calls David Whitmer, Peter Whitmer Jr., and John Whitmer to preach the gospel*

Imagine what it would be like to receive a call to serve the Lord as a full-time missionary. Write some of the feelings you think you might experience in receiving such a call: \_\_\_\_\_

The Lord called three of the Whitmer brothers, David, Peter Jr., and John, to preach the gospel and gave specific counsel to each one.

Read the verses from Doctrine and Covenants 30 in the first column of the following chart, and then find a principle in the second column that is taught in those verses. Write the letter of the statement on the line next to the name and scripture reference. The correct answers are listed at the end of this lesson.

## UNIT 8: DAY 2

# Doctrine and Covenants 30–32

### Introduction

In the revelation recorded in Doctrine and Covenants 30, the Lord gave instructions to David Whitmer, Peter Whitmer Jr., and John Whitmer. Thomas B. Marsh received a call to preach, as recorded in Doctrine and Covenants 31. In the revelation recorded in Doctrine and Covenants 32,

<p>___ 1. David (verses 1–4)</p> <p>___ 2. Peter (verses 5–8)</p> <p>___ 3. John (verses 9–11)</p>	<p>a. <b>We should serve the Lord with all our soul because He will be with us.</b></p> <p>b. <b>Rather than fear men, we should rely on the Lord for strength.</b></p> <p>c. <b>We are to sustain and support those whom the Lord has called to direct His work.</b></p>
--	---





1. Choose one of the bolded principles in the preceding chart. In your scripture study journal, write about a situation you might face in which this principle would be especially helpful.

## Doctrine and Covenants 31:1–8

*The Lord calls Thomas B. Marsh to preach the gospel and help establish the Church*

Think about your family and the feelings you have for them. Is there anyone in your family who is not a member of the Church or not keeping his or her covenants with the Lord? If so, what are your hopes for this person? In Doctrine and Covenants 31 we read a revelation directed to a recent convert, Thomas B. Marsh. Part of it was about his family. Thomas was married and had three young children at the time this revelation was given. Read Doctrine and Covenants 31:1–2, looking for the promises the Lord gave to Thomas concerning his family.

We learn from these verses that **through our faithfulness, our family members may be blessed to believe and know the truth**. Consider how this principle may be helpful for you if you have family members who are not members of the Church or are not keeping their covenants.



2. In your scripture study journal, answer the following questions:

- a. What are some ways individuals may be blessed through the faithfulness of their family members?
- b. What examples of this have you seen?

Read Doctrine and Covenants 31:3–4, and identify what the Lord called Thomas B. Marsh to do.

It may not have been easy for Thomas to leave his family to preach the gospel, just as it may not be easy for missionaries today. Read the following statement, and mark the promises President Gordon B. Hinckley made to those who serve the Lord as missionaries: “You will bless the lives of those you teach, and their posterity after them. You will bless your own life. You will bless the lives of your family, who will sustain you and pray for you” (“Of Missions, Temples, and Stewardship,” *Ensign*, Nov. 1995, 52).

Read Doctrine and Covenants 31:5–8, and identify the blessings that would come to those whom Thomas B. Marsh would teach as a missionary. Also look for blessings that would come to Thomas and his family. You may want to mark what you find.

## Doctrine and Covenants 31:9–13

*Jesus Christ gives personal counsel to Thomas B. Marsh*

In Doctrine and Covenants 31:9–13, the Lord gave counsel to help Thomas B. Marsh on his mission and in his personal life.



3. In your scripture study journal, identify one item of counsel the Lord gave to Thomas B. Marsh that you feel is important for you to follow in your life, and then answer the following question: Why do you think this counsel is important for you, and how can you benefit from following it?

Read Doctrine and Covenants 31:13 again, and identify the promise given to Thomas B. Marsh if he would be faithful in obeying the counsel the Lord had given him.

Using the words *if* and *then*, write the promise in the form of a principle statement.

If \_\_\_\_\_,  
then \_\_\_\_\_.



4. Make two columns in your scripture study journal. Label one column *Righteous Habits* and the other column *Righteous Choices*. List practices you have adopted or need to adopt and choices you have made or need to make now and in the future that will help you “be faithful unto the end” (D&C 31:13).

## Doctrine and Covenants 32

*The Lord calls Parley P. Pratt and Ziba Peterson to join the mission to the Lamanites*

The revelations you have studied in Doctrine and Covenants 30–31 and those you will study in Doctrine and Covenants 32–34 are about mission calls, missionary work, and preparations to teach the restored gospel of Jesus Christ. In October 2012, President Thomas S. Monson announced a change in age of missionary service based on the obedience, faithfulness, and maturity of the rising generation:



“I am pleased to announce that effective immediately all worthy and able young men who have graduated from high school or its equivalent, regardless of where they live, will have the option of being recommended for missionary service beginning at the age of 18, instead of age 19. I am not suggesting that all young men will—or should—serve at this earlier age. Rather, based on individual circumstances as well as upon a determination by priesthood leaders, this option is now available.

“As we have prayerfully pondered the age at which young men may begin their missionary service, we have also given consideration to the age at which a young woman might serve. Today I am pleased to announce that able, worthy young women who have the desire to serve may be recommended for missionary service beginning at age 19, instead of age 21.

“We affirm that missionary work is a priesthood duty—and we encourage all young men who are worthy and who are physically able and mentally capable to respond to the call to serve. Many young women also serve, but they are not under the same mandate to serve as are the young men. We assure the young sisters of the Church, however, that they make a valuable contribution as missionaries, and we welcome their service” (“Welcome to Conference,” *Ensign* or *Liahona*, Nov. 2012, 4–5).

As you continue to study these revelations about missionary work, think about similarities and differences in the preparation and work of the early missionaries and of missionaries throughout the world now.

Locate Fayette, New York, and Independence, Missouri, on the accompanying map (see also Church history map 6, “The Westward Movement of the Church,” in your scriptures or LDS.org). How far apart do you think these locations are from each other? \_\_\_\_\_

The Lord called Oliver Cowdery and Peter Whitmer Jr. to travel from New York to Missouri to preach the gospel to the Lamanites on the western border of Missouri (see D&C 28:8; 30:5). This mission to the Lamanites generated great excitement among the elders of the Church, and some desired to know if additional elders might be sent to accompany Oliver and Peter on this mission. The revelation in Doctrine and Covenants 32 is the Lord’s answer.

Parley P. Pratt was baptized in September 1830, only one month before this revelation was given. He had learned about the Book of Mormon while traveling in New York during the summer of 1830. He later wrote of his response after he obtained a copy of the book:





"I opened it with eagerness, and read its title page. I then read the testimony of several witnesses in relation to the manner of its being found and translated. After this I commenced its contents by course. I read all day; eating was a burden, I had no desire for food; sleep was a burden when the night came, for I preferred reading to sleep.

"As I read, the spirit of the Lord was upon me, and I knew and comprehended that the book was true, as plainly and manifestly as a man comprehends and knows that he exists" (*Autobiography of Parley Parker Pratt*, ed. Parley P. Pratt [1938], 37).

Parley traveled to Palmyra, New York, where he learned more about the Restoration of the gospel from Hyrum Smith. Soon, Hyrum and Parley journeyed to Fayette, where Parley joined the Church and was ordained an elder by Oliver Cowdery.

Little is known about the conversion of Ziba Peterson other than he was baptized by Oliver Cowdery in April 1830 and ordained an elder in June.

Read Doctrine and Covenants 32:1–5 to learn what the Lord called Parley and Ziba to do, as well as what the Lord promised them.



**5.** Answer the following questions in your scripture study journal:

- How is the promise in Doctrine and Covenants 32:3 similar to the promises the Lord gave to John Whitmer in Doctrine and Covenants 30:11 and to Thomas B. Marsh in Doctrine and Covenants 31:13?
- What do these promises teach you about the Lord's feelings for those who serve Him as missionaries?



During the winter of 1830–31, Oliver Cowdery, Peter Whitmer Jr., Parley P. Pratt, and Ziba Peterson traveled from Fayette, New York, to Independence, Missouri, a distance of nearly 1,500 miles (about 2,400 kilometers), much of the way on foot. They endured deep snow, intense cold, strong winds, and exhaustion, living primarily on frozen corn bread and raw pork.

In spite of these hardships, the missionaries succeeded in introducing the gospel to Native American tribes in New York, Ohio, and Missouri. They also preached the

gospel in Kirtland, Ohio, to a congregation of people who were looking for a restoration of New Testament Christianity. Many of those people joined the Church. One of those converts from Ohio, Frederick G. Williams, accompanied the missionaries on the remainder of their journey to Missouri. The Lord fulfilled His promise that He would be with these missionaries and that nothing would prevail against them.



**6.** Write the following at the bottom of today's assignments in your scripture study journal:

*I have studied Doctrine and Covenants 30–32 and completed this lesson on (date).*

*Additional questions, thoughts, and insights I would like to share with my teacher:*

Answers to the matching activity for Doctrine and Covenants 30: (1) b, (2) c, (3) a.

## UNIT 8: DAY 3

# Doctrine and Covenants 33–34

## Introduction

In the revelation recorded in Doctrine and Covenants 33 the Lord called Ezra Thayre and Northrop Sweet to proclaim the gospel of Jesus Christ. The Lord also gave these men instructions for teaching the gospel. As recorded in Doctrine and Covenants 34, the Lord commended Orson Pratt for his faith and also commanded him to preach the gospel.

## Doctrine and Covenants 33:1–6

*The Lord calls Ezra Thayre and Northrop Sweet to proclaim His gospel*

God communicates with His children in many different ways. What is an example of how He has communicated with you or with someone you know?

One way the Lord may communicate with us is through dreams and visions. Read the following account of a vision experienced by Ezra Thayre. Consider how his vision relates to a roll of paper, an ear, and a trumpet. Also, think about what the meaning of this vision might be.

“A man came and brought me a roll of paper and presented it to me, and also a trumpet and told me to blow it. I told him that I never blew any in my life. He said you can blow it, try it. I put it in my mouth and blowed on it, and it made the most beautiful sound that I ever heard” (“Testimony of Brother E. Thayre,” *The True Latter Day Saints’ Herald*, Oct. 1862, 82).

Ezra Thayre lived in Palmyra, New York, and had come to know members of the Smith family through work they had done for him at various times. In October 1830, Ezra Thayre and another resident of Palmyra, Northrop Sweet, were baptized into the Church. Shortly after Ezra and Northrop were baptized, the Prophet Joseph Smith received a revelation addressed to these two men, which is now Doctrine and Covenants 33. Many years later Ezra explained, “The roll of paper was the revelation on me and Northrop Sweet” (“Testimony of Brother E. Thayre,” 82).

### Understanding Symbols in the Scriptures

The Lord and His prophets often use symbols to help teach gospel truths. The scriptures are full of symbols and images that carry great meaning. As you study the scriptures, look for symbols. When you find them, pause to think about what they may represent.



**1.** In your scripture study journal, answer the following questions:

- a. What do you think it means to declare the gospel “as with the sound of a trump” (D&C 32:2)?
- b. In Ezra Thayre’s vision, when he played the trumpet, it produced the most beautiful sound he had ever heard. From what you learned in Doctrine and Covenants 33:2, why do you think the sound was so beautiful?

In Doctrine and Covenants 33:3, the Lord used additional symbols to teach Ezra and Northrop about their calling as missionaries. Read this verse, and think about the symbols it contains. In the following activity, draw a line to match each symbol with its meaning.

Read Doctrine and Covenants 33:1–2, and look for words and phrases that relate to a roll of paper, an ear, and a trumpet.

Consider what it means to “open . . . your ears and hearken to the voice of the Lord your God” (D&C 32:1). Ponder how you can show the Lord your ears are open to hearing His voice.

Symbol	Meaning
The field or vineyard	Members of the Church of Jesus Christ who serve to build up God’s kingdom on earth
The laborers	The world
The eleventh hour	The final dispensation of the gospel and the last time the Lord will set up His kingdom on earth before His Second Coming (see Bible Dictionary, “Dispensations”)

Read Doctrine and Covenants 33:4, looking for how the Lord described the condition of the world in 1830. What challenges do you see in the Lord’s vineyard today?

Ponder what the Lord has done or is doing to help you live in this corrupt world. Read Doctrine and Covenants 33:5–6. What did the Lord say He has done to help us?



**2.** In your scripture study journal, draw a picture that illustrates one way God has helped people avoid the corruption of the world.

You may want to mark words or phrases from Doctrine and Covenants 33:5–6 that teach the following truth:

**The Lord has established His Church and is gathering His elect in the last days.**



**3.** To help you further understand this truth and its importance, answer the following questions in your scripture study journal:

- a. According to Doctrine and Covenants 33:6, who are the elect?
- b. Considering the corruptness of the world, why would it be important for the Lord’s elect to gather together?
- c. How has the Church helped you avoid the corruptness of the world?



## Doctrine and Covenants 33:7–18

*The Lord gives Ezra Thayre and Northrop Sweet instructions for teaching the gospel*

Read Doctrine and Covenants 33:7–10 to learn what the Lord taught Ezra Thayre and Northrop Sweet they were to do with their mouths. Next to the following picture, write a principle based on what you learned from these verses. The principle could begin: **If we open our mouths to declare the gospel, the Lord will . . .**



-  **4.** Think of a time when you felt like you should have spoken up about the gospel but did not. In your scripture study journal, answer the following questions:
- What are some situations in which you might be reluctant to open your mouth about the gospel?
  - When have you shared the gospel and felt inspired to know what to say? Or when have you seen others share the gospel and felt they were inspired in what they said?

Doctrine and Covenants 33:10–15 contains the Lord’s instructions to Ezra and Northrop to preach the first principles and ordinances of the gospel (faith in Jesus Christ, repentance, baptism, and the gift of the Holy Ghost). Study Doctrine and Covenants 33:16–18 to learn what additional counsel the Lord gave Ezra and Northrop that would help them know what to say as missionaries. You may want to mark what you find. The counsel in verse 17 to have “your lamps trimmed and burning, and oil with you” means to be spiritually prepared and ready at all times for the Second Coming of Jesus Christ.

-  **5.** In your scripture study journal, write one item of counsel given in Doctrine and Covenants 33:16–18, and explain how it could help you be ready to open your mouth and share the gospel with others at any time.

## Doctrine and Covenants 34

*The Lord commends Orson Pratt for his faith and calls him to preach the gospel*

Doctrine and Covenants 34 gives an example of someone who was blessed when another person opened his mouth to share the gospel. Read the section introduction to this revelation in your scriptures to learn who opened his mouth to share the gospel with Orson Pratt.

Orson Pratt was 19 years old when he was baptized by his older brother Parley. Read Doctrine and Covenants 34:1, and notice how the Lord addressed Orson.

Now study Doctrine and Covenants 34:2–3, looking for the reason why the Lord referred to Orson as His son.

You may have noticed in verse 3 that all who believe in Jesus Christ become His sons. This is symbolic of the new life we receive as we accept the Savior’s gospel. We learn from Doctrine and Covenants 25:1 that this promise applies equally to females, who become daughters of Jesus Christ as they accept His gospel.

As you read the following information Orson Pratt wrote about his early life, mark what he did to show he believed in the Lord:



“From the age of ten to nineteen I saw much of the world, and was tossed about without any permanent abiding place; but through the grace of God, I was kept from many of the evils to which young people are exposed; the early impressions of morality and religion, instilled into my mind by my parents, always remained with me; and I often felt a great anxiety to be prepared for a future state; but never commenced, in real earnest, to seek after the Lord, until the autumn of 1829. I then began to pray very fervently, repenting of every sin. In the silent shades of night, while others were slumbering upon their pillows, I often retired to some secret place in the lonely fields or solitary wilderness, and bowed before the Lord, and prayed for hours with a broken heart and contrite spirit; this was my comfort and delight. The greatest desire of my heart was for the Lord to manifest His will concerning me. I continued to pray in this fervent manner until September, 1830, at which time two Elders of the Church of Jesus Christ of Latter-day Saints, came into the neighborhood, one of which was my brother Parley. They held several meetings which I attended.

“Being convinced of the divine authenticity of the doctrine they taught, I was baptized September 19, 1830. This was my birthday, being nineteen years old.

I was the only person in the [area] who received and obeyed the message” (in *The Orson Pratt Journals*, comp. Elden J. Watson [1975], 8–9).

Read Doctrine and Covenants 34:4–6 to see what the Lord called Orson Pratt to do to be even more blessed. Consider why we receive greater blessings when we teach the gospel to others.

The Lord spoke to Orson about some of the signs that would occur before His Second Coming (see D&C 34:7–9). He then concluded this revelation by encouraging Orson in his calling to preach the gospel. Read Doctrine and Covenants 34:10–12, looking for the following truths: **Those who diligently teach the gospel will do so by the power of the Holy Ghost. If we are faithful, the Lord will be with us.**

How might the Lord’s promise in Doctrine and Covenants 34:11 comfort and strengthen someone during a time of discouragement?

 **6.** In your scripture study journal, describe why you think it is essential to have the power of the Holy Ghost to help you as you teach the gospel to others.

 **7.** Write the following at the bottom of today’s assignments in your scripture study journal:

*I have studied Doctrine and Covenants 33–34 and completed this lesson on (date).*

*Additional questions, thoughts, and insights I would like to share with my teacher:*

## UNIT 8: DAY 4

# Doctrine and Covenants 35

### Introduction

Within six months of the Church’s organization, four missionaries, including Parley P. Pratt, journeyed west to preach to the Native Americans. On their way to the western borders of Missouri, they stopped in the area around Kirtland, Ohio, where Parley had lived for a time. They shared their message with Elder Pratt’s friend, a prominent minister named Sidney Rigdon. In a short time, more than 100 people, including Sidney Rigdon and many members of his congregation, had been baptized, more than doubling the Church’s total membership. Sidney and his wife, Phoebe, knew that

joining the Church would be a great sacrifice for them. He knew that his livelihood as a minister and his reputation in the community would suffer, but he was determined to follow the truth.

After the elders left Kirtland to continue their journey, Sidney Rigdon and a friend, Edward Partridge, went to New York to meet the Prophet Joseph Smith. Soon after their arrival, the Prophet received the revelation recorded in Doctrine and Covenants 35. In it, the Lord gave Sidney Rigdon specific responsibilities within the newly restored Church.

## Doctrine and Covenants 35:1–12

*The Lord tells Sidney Rigdon he has been prepared for a greater work*

 **1.** In your scripture study journal, answer the following question: What have you experienced that helps you know that God is aware of you?

The revelation recorded in Doctrine and Covenants 35 shows that the Lord knew Sidney Rigdon, and He spoke to Sidney about his role in assisting the Prophet Joseph Smith. Read Doctrine and Covenants 35:1–3, looking for evidence that the Lord was aware of Sidney Rigdon. You may want to mark what you find.

Read Doctrine and Covenants 35:3 again, replacing Sidney’s name with your own. What do the Lord’s words teach about His awareness of us? \_\_\_\_\_



Elder Neal A. Maxwell of the Quorum of the Twelve Apostles testified of God’s awareness of each of us: “I testify to you that God has known you individually . . . for a long, long time (see D&C 93:23). He has loved you for a long, long time. . . . He

knows your names and all your heartaches and your joys!” (“Remember How Merciful the Lord Hath Been,” *Ensign*, May 2004, 46).

One principle we can learn from Doctrine and Covenants 35:3 is that **the Lord knows us and has a work for each of us to do**. Have you ever wondered what specific work the Lord has for you to do during your life?

Before he learned about the restored Church of Jesus Christ, Sidney Rigdon had been doing a good work as a minister of another church. After joining the Lord’s restored Church, he was able to perform “a greater work” (D&C 35:3) for the Lord’s kingdom. People of other faiths can do many good things. It is our responsibility to share with them the fulness of

the gospel of Jesus Christ so they can do “a greater work.” Similarly, we can have confidence that the Lord is aware of us and that as we strive to follow Him, He will help us accomplish the work we are meant to do.



As a forerunner to Jesus Christ, John the Baptist prepared many people’s hearts for His coming. Read Doctrine and Covenants 35:4–6, and look for how Sidney Rigdon was like John the Baptist. You might want to mark what you find.

While Sidney Rigdon had been like John the Baptist in some ways, he was different from John the Baptist because when Sidney had baptized people in his former congregation, he had not had authority from God to do so (see D&C 35:5–6).

Read Doctrine and Covenants 35:7–11, and look for what can occur in the lives of those who believe and exercise faith in God in the last days.

 **2.** Answer the following questions in your scripture study journal:

**a.** What can we learn from Doctrine and Covenants 35:7–11 about what the Lord promised to show those who follow Him in faith? (The word *Gentiles* in verse 7 refers to those without the fulness of the gospel. The word *Babylon* in verse 11 refers to the world.)

**b.** Why do you think miracles are so closely linked to faith in Jesus Christ? (Consider that miracles can be as subtle as a change of heart or forgiveness of sin and they come according to the Lord’s will.)

## Doctrine and Covenants 35:13–19

*The Lord promises to help the humble do His work*

Imagine that you were putting together a sports team (think of a sport you are familiar with). In the space provided, describe the strengths and skills you would want your players to have. \_\_\_\_\_

Read Doctrine and Covenants 35:13, looking for whom the Lord selects to accomplish His work. Notice the characteristics of those the Lord chooses to assist Him that are unusual by the world’s standards. “The weak things of the world” refers to the Lord’s servants. The



word *thresh* or *thresh* in this verse refers to threshing, which is the practice of separating grain from its stalk and sheath. In this verse it refers to separating and gathering the people who are ready to receive the gospel from those who are not. One way this is done is by missionaries contacting people and preparing them to make and keep sacred covenants.

Based on Doctrine and Covenants 35:13, we learn that **God calls upon those who are weak to accomplish His work through the power of His Spirit.**

 **3.** Answer the following question in your scripture study journal: Why do you think the Lord refers to His servants as “weak,” “unlearned,” and “despised”?

Read Doctrine and Covenants 35:14–15, looking for the Lord’s promises to those who assist in His work. You might want to mark what you find. You could also personalize these verses by reading them again and inserting your name.

### Personalizing the Scripture Text

Inserting your name in the scripture text can help the truths of the passage be more meaningful to you. Reading the scriptures as though they were written to you can be a helpful way to “hear the voice of the Lord Jesus Christ, speaking to [you]” (Explanatory Introduction to the Doctrine and Covenants).





4. In your scripture study journal, answer two or all of the following questions:

- How could knowing that God uses the weak things of the world to accomplish His work through the power of His Spirit help a young person who felt nervous about serving a mission?
- How could this knowledge help a young woman who was asked to teach a Church class and felt inadequate?
- How could this knowledge help all of us when we feel prompted to share the gospel with someone?



President Thomas S. Monson encouraged those who may feel weak or inadequate to assist in the Lord's work: "Some of you may be shy by nature or consider yourselves inadequate to respond affirmatively to a calling. Remember that

this work is not yours and mine alone. It is the Lord's work, and when we are on the Lord's errand, we are entitled to the Lord's help. Remember that the Lord will shape the back to bear the burden placed upon it" ("To Learn, to Do, to Be," *Ensign* or *Liahona*, Nov. 2008, 62).

The Prophet Joseph Smith would be considered by some to be weak in formal education and some other abilities. Sidney Rigdon, in comparison, was well educated and gifted in a number of ways. Read Doctrine and Covenants 35:17–19, and look for the Lord's counsel to Sidney Rigdon regarding the Prophet Joseph.



5. Answer the following questions in your scripture study journal:

- Why would the counsel in Doctrine and Covenants 35:17–19 be important for an educated minister like Sidney Rigdon to understand?
- How would it be helpful for us to remember this counsel with regard to our current Church leaders?

### Doctrine and Covenants 35:20–27

*Sidney Rigdon is commanded to write for Joseph Smith, to preach the gospel, and to keep his covenants*

Do you have any specific callings or duties in the Church? Read Doctrine and Covenants 35:20–24, and look for the specific duties Sidney Rigdon was called to perform.

The Lord called Sidney to fill the role of scribe as the Prophet Joseph Smith continued his translation of the Bible. This translation was not from one language to another. The Prophet made inspired corrections and revisions to the Bible over a 16-year period. We call these revisions the Joseph Smith Translation. Many of these corrections can be found in the footnotes and appendix of the LDS edition of the Holy Bible. The Book of Moses and Joseph Smith—Matthew in the Pearl of Great Price are also part of the Joseph Smith Translation.

Notice in Doctrine and Covenants 35:23 that the Lord told Sidney Rigdon that besides writing for Joseph Smith, he should also preach the gospel, using his knowledge of the scriptures to support the Prophet's words.

In Doctrine and Covenants 35:24, what blessings did the Lord promise Sidney Rigdon if he kept his covenants? One principle we can learn from this verse is that **as we keep the commandments and honor our covenants, the Lord will help us accomplish His work.**



6. Look back at the three principles identified in this lesson. In your scripture study journal, answer the following questions:

- How do the three principles identified in this lesson relate to each other?
- When have you felt or witnessed the Lord's help given to you or someone you know while doing the Lord's work?

To conclude, read Doctrine and Covenants 35:26–27. From what you learned during your study of Doctrine and Covenants 35 today, why do you think Sidney Rigdon had reason to lift up his heart and be glad? What reasons do you have to lift up your heart and be glad?



7. Write the following at the bottom of today's assignments in your scripture study journal:

*I have studied Doctrine and Covenants 35 and completed this lesson on (date).*

*Additional questions, thoughts, and insights I would like to share with my teacher:*



# Doctrine and Covenants 36–37

## Introduction

In December 1830, Sidney Rigdon traveled from Ohio to New York with Edward Partridge to meet with the Prophet Joseph Smith. Although Sidney had recently been baptized, Edward was not yet convinced of the truthfulness of the restored gospel. After meeting the Prophet and speaking with those who knew him, Edward asked the Prophet to baptize him. In early December 1830, before Edward Partridge was baptized, Joseph Smith received the revelation in Doctrine and Covenants 36. In the revelation the Lord called and commanded Edward Partridge to preach the gospel.

During the last six months of 1830, persecution against the Church was intensifying. In December of 1830 Joseph received the revelation in Doctrine and Covenants 37, in which the Lord commanded the Saints to leave New York and gather to Ohio.

## Doctrine and Covenants 36:1–3

*The Lord forgives Edward Partridge of his sins and calls him to preach the gospel*

Think about several items that missionaries take with them to help them accomplish their work.



Some things that missionaries need before they can effectively preach the gospel cannot be put into a suitcase. As you study Doctrine and Covenants 36, look for some of the things that a missionary needs and must do before he or she is prepared to serve a mission.

In Doctrine and Covenants 36, the Lord called Edward Partridge to serve a mission. Read Doctrine and Covenants 36:1, looking for what the Lord told Edward Partridge before calling him to preach the gospel.



1. In your scripture study journal, write why you think it is important for all who are called to preach the gospel to repent and be forgiven of their sins. Consider how being cleansed from sin would help Edward Partridge to preach the gospel “as with the voice of a trump” (D&C 36:1).



Read the following statement from Elder Jeffrey R. Holland of the Quorum of the Twelve Apostles, and mark the words or phrases that help you understand why it is important for those who are called to preach the gospel to be clean:

“In this battle between good and evil, you cannot play for the adversary whenever temptation comes along and then expect to suit up for the Savior at temple and mission time as if nothing has happened. That, my young friends, you cannot do. God will not be mocked.

“. . . In almost all athletic contests of which I know, there are lines drawn on the floor or the field within which every participant must stay in order to compete. Well, the Lord has drawn lines of worthiness for those called to labor with Him in this work. No missionary can be unrepentant of sexual transgression or profane language or pornographic indulgence and then expect to challenge others to repent of those very things! You can’t do that. The Spirit will not be with you, and the words will choke in your throat as you speak them. You cannot travel down what Lehi called ‘forbidden paths’ [1 Nephi 8:28] and expect to guide others to the ‘strait and narrow’ [2 Nephi 31:18] one—it can’t be done” (“We Are all Enlisted,” *Ensign* or *Liahona*, Nov. 2011, 45).

Consider what it would be like for you to share the gospel with others while personally knowing that you have not lived the truths that you are teaching. Now, consider what it would be like to share the gospel with others having the confidence that comes from being cleansed of any wrongdoing through the Atonement of Jesus Christ.

Elder Holland talked about what you can do now to be clean for missionary service: “Whoever you are and whatever you have done, you can be forgiven. Every one of you . . . can leave behind any transgression with which you may struggle. It is the miracle of forgiveness; it is the miracle of the Atonement of the Lord Jesus Christ. But you cannot do it without an active commitment to the gospel, and you cannot do it without repentance where it is needed. I am asking

you . . . to be active and be clean. If required, I am asking you to *get* active and *get* clean” (“We Are all Enlisted,” 45).

Ponder what you need to do now to become clean or to remain clean.

Read Doctrine and Covenants 36:2–3, looking for what the Lord promised to give Edward Partridge before he would be sent to preach the gospel.



President Harold B. Lee explained the meaning of the phrase “I will lay my hand upon you by the hand of my servant” found in verse 2: “The Lord here is saying that when one of His authorized servants puts his hands by authority upon the

head of one to be blessed, it is as though He Himself was putting His hand on with them to perform that ordinance. So we begin to see how He manifests His power among men through His servants to whom He has committed the keys of authority” (*Be Secure in the Gospel of Jesus Christ*, Brigham Young University Speeches of the Year [Feb. 11, 1958], 6).

It might also be helpful to know that the phrase “teach you the peaceable things of the kingdom” in verse 2 refers to the inspiration and guidance we receive from the Holy Ghost as we live the gospel.

Notice in verse 3 what the Lord told him to do with what the Holy Ghost had taught him.



**2.** Answer the following question in your scripture study journal: Why do you think it is essential for missionaries to have the Holy Ghost as their companion? After answering this question, you may also want to write about a time when the Holy Ghost taught you something about “the peaceable things of the kingdom” (D&C 36:2).

## Doctrine and Covenants 36:4–8

*The Lord gives a commandment regarding those who are called to preach the gospel*

Read Doctrine and Covenants 36:4–5, 7. Notice that in these verses, the Lord is speaking to “the elders of [His] church” (D&C 36:7). As you read, look for a responsibility the Lord gave to priesthood holders.

Based on what you read in these verses, complete the following principle concerning the responsibility of all priesthood holders today: **Priesthood holders are called to** \_\_\_\_\_.



President Thomas S. Monson commented on this principle: “I repeat what prophets have long taught—that every worthy, able young man should prepare to serve a mission. Missionary service is a priesthood duty—an obligation the Lord expects of us who have been given so very much” (“As We Meet Together Again,” *Ensign* or *Liahona*, Nov. 2010, 5–6).

Bishops and branch presidents work with young men and young women to determine their worthiness and ability to serve the Lord as full-time missionaries. Some young men may be excused from full-time missionary service because of health concerns or disabilities. However, in such cases they are to maintain their worthiness and prepare themselves to serve the Lord in other ways.

Review Doctrine and Covenants 36:5, 7 to see what priesthood holders need to do before they are ordained and sent forth to preach the gospel.



**3.** Answer the following question in your scripture study journal: How can a young man show the Lord that he embraces the commandment to preach the gospel?

# Doctrine and Covenants 38

Although full-time missionary service is a priesthood duty, young women may also serve. President Thomas S. Monson said: “A word to you young sisters: while you do not have the same priesthood responsibility as do the young men to serve as full-time missionaries, you also make a valuable contribution as missionaries, and we welcome your service” (“As We Meet Together Again,” 6).

Read Doctrine and Covenants 36:6, looking for the message the Lord commands His missionaries to teach. The phrase “garments spotted with the flesh” refers to clothing that is contaminated by disease. In ancient Israel, such clothing was burned to prevent the disease from spreading. In verse 6, the Lord is comparing disease to sin and commands us to avoid anything associated with sin.

How does the message in Doctrine and Covenants 36:6 that missionaries are to proclaim repentance relate to Elder Holland’s statements about how missionaries are to prepare at the beginning of this lesson? \_\_\_\_\_

Read Doctrine and Covenants 36:8, looking for what the Lord told Edward Partridge at the end of this revelation.

## Doctrine and Covenants 37

*The Lord commands His Church to gather in Ohio*

During the months leading up to the time when Edward Partridge traveled to meet Joseph Smith, persecution of the Saints was increasing in New York. Near the end of December 1830, a few weeks after Sidney Rigdon and Edward Partridge arrived in New York, the Prophet Joseph Smith received a revelation in which the Lord commanded the Saints to go to Ohio.

Read Doctrine and Covenants 37:1–4, looking for what preparations the Lord wanted the Prophet to make before he went to Ohio. Notice in verse 2 why the Lord told Joseph Smith to go and strengthen the members in Colesville, New York.

What principles about prayer can we learn from these verses?

 **4.** In your scripture journal, write a principle you learn from Doctrine and Covenants 37:2 about prayer. Also, explain what you will do to act on this principle.

 **5.** Write the following at the bottom of today’s assignments in your scripture study journal:

*I have studied Doctrine and Covenants 36–37 and completed this lesson on (date).*

*Additional questions, thoughts, and insights I would like to share with my teacher:*

## Introduction

In December 1830 the Lord commanded the Church members to gather in Ohio (see D&C 37). On January 2, 1831, the Saints from the various branches in New York met for the third conference of the Church. During the conference the revelation in Doctrine and Covenants 38 was received, in which the Lord encouraged the Saints and helped them understand His commandment to go to Ohio.

## Doctrine and Covenants 38:1–7

*Jesus Christ tells His Saints that He is in their midst*

Have you ever noticed that some commandments may be easy for you to obey and other commandments may be more difficult? List some of the commandments that you feel are easy for you to obey: \_\_\_\_\_

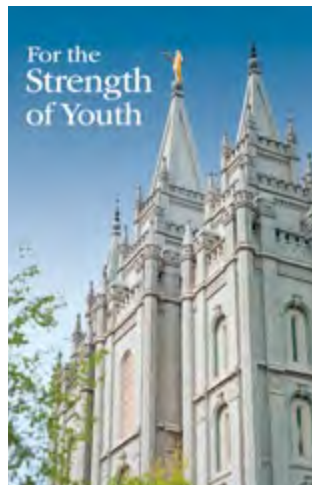

Now, ponder which commandments may be more difficult for you to obey and why.

During a conference of the Church in January 1831, some of the Saints in New York asked about the commandment to move to Ohio. Consider why it might have been difficult for some of these Church members to obey this commandment.

Some of the Saints in New York were reluctant to leave their prosperous farms and comfortable circumstances for the uncertainties of a new place. In addition, some faced the prospect of losing money in selling their property, if they were able to sell their property at all.

In response to the Saints’ concerns, Joseph Smith prayed to learn more about the commandment to gather to Ohio, and he received the revelation in Doctrine and Covenants 38. As you study this revelation, you will learn truths that can help you



willingly obey all of the Lord's commandments, even those that are more difficult for you to obey.

Read Doctrine and Covenants 38:1–3, looking for principles you can learn about Jesus Christ. (You may want to mark in the scriptures or note in your scripture study journal what you learn.)

One important doctrine we learn from verse 2 is that **Jesus Christ knows all things**. Think of how understanding this doctrine might have helped those Saints who struggled to obey the commandment to leave New York and move to Ohio.

 **1.** In your scripture study journal, write a few sentences about how this principle might also help you in times when you struggle to obey certain commandments the Lord has given.

Before receiving this revelation, the Prophet Joseph Smith had been working on the inspired translation of the Bible and received what is now contained in Moses 6–7 in the Pearl of Great Price. These chapters give an account of a prophet named Enoch and his people, who were called Zion because of their righteousness.

Read Doctrine and Covenants 38:4, looking for what the Lord did for Enoch and his people. It may be helpful for you to know that when the Lord said “mine own bosom,” He was referring to His presence.

At the end of verse 4, what did the Savior say He had done for those who believed on His name? \_\_\_\_\_

Ponder how knowing that Jesus Christ pleads to Heavenly Father in behalf of those who believe in Him helps someone who is struggling to keep trying.

Read Doctrine and Covenants 38:5–7, looking for what Jesus Christ said about where He is.

 **2.** Answer the following question in your scripture study journal: How can believing the principles taught in Doctrine and Covenants 38:7 help bring you comfort as well as courage?

## Doctrine and Covenants 38:8–12

### *The Lord describes who will abide His Second Coming*

As the Savior was helping the Saints in New York understand the importance of gathering to Ohio, He spoke of His Second Coming.



Read Doctrine and Covenants 38:8–10, looking for what the Savior revealed about His Second Coming. It may be helpful for you to know that those who “abide the day” (D&C 38:8) of the Second Coming are those who, rather than being destroyed, will be able to remain on the earth with the Savior when He comes. Ponder how the Lord’s words in verses 8–10 can help you understand the importance of being purified and clean before the Second Coming.

Read Doctrine and Covenants 38:11–12 to learn about some of the conditions that will exist on the earth before the Second Coming. The imagery of angels waiting to “reap down the earth” is a reference to the Savior’s parable of the wheat and the tares (see Matthew 13:24–30; D&C 86:1–7) in which the wheat (those who are righteous) is gathered before the tares (those who are wicked) are gathered and burned.

Ponder what you can do to better prepare yourself to “abide the day” of the Second Coming of Jesus Christ and not be found among the tares.



## Doctrine and Covenants 38:13–33

*Jesus Christ explains why He commanded the members of His Church to gather to Ohio*

Think about a time you felt that you were in danger, either physically or spiritually. What warnings helped you know you were in danger?

The Lord warned the Saints about dangers they would face if they remained in New York. Look at the last phrase of Doctrine and Covenants 38:12. What did the Lord teach about the enemy of the Saints?

Read Doctrine and Covenants 38:13, 28–29, looking for the intentions of the combined enemy. From these verses we learn that **the Lord can warn us of danger**. Such warnings can come through promptings of the Holy Ghost or through the teachings of the Lord’s servants, including talks given in general conferences.

 **3.** When have you or someone you know been warned by the Lord of a spiritual or physical danger? In your scripture study journal, write about a warning you or a family member or friend received from the Lord and what you did (or wished you had done) or what the family member or friend did in response to that warning.

Read Doctrine and Covenants 38:14–15, 30, looking for what the Lord told the Saints to do. From what you learn at the end of verse 30, complete the following principle: **If we are \_\_\_\_\_, then \_\_\_\_\_.**

 **4.** Answer the following questions in your scripture study journal:

- Why do you think preparation gives us confidence in the face of opposition or danger?
- What can you do to be prepared against the adversary’s efforts to harm you?

Remember that some of the Saints in New York questioned why they were commanded to go to Ohio. Read Doctrine and Covenants 38:16, 31–33, and identify how the Saints would be blessed if they obeyed this commandment.

 **5.** Answer the following questions in your scripture study journal:

- How might the commandment to move from New York have been for the Saints’ physical salvation?
- How could the commandment to gather to Ohio have been for their spiritual salvation?

From Doctrine and Covenants 38:16, 31–33, we learn that **the Lord not only warns us of danger, but He also gives us commandments for our protection**.

 **6.** In your scripture study journal, write a few sentences explaining how keeping the commandments can protect us both physically and spiritually.

## Doctrine and Covenants 38:34–42

*The Church is given commandments regarding the gathering to Ohio*

Doctrine and Covenants 38:34–42 contains commandments and counsel that would help the Saints in their transition to life in Ohio. For many of the Saints, their only source of livelihood was their farms. With so many members of the Church putting their land up for sale at the same time, the supply of land suddenly became abundant. With so many choices available, buyers could purchase the Saints’ farms for much less than the usual price.

Read Doctrine and Covenants 38:37, 39, looking for the Lord’s counsel to the Saints regarding their farms and riches. Consider how having faith in the Lord’s eternal promises can help us obey His commandments even when they require a sacrifice on our part.

Many of the Saints in New York were obedient to the Lord’s command and made great sacrifices to gather to Ohio.

 **7.** At the beginning of today’s lesson, you were asked to think about some commandments that may be more difficult for you to obey than others. In your scripture study journal, write about how understanding the principles you learned in this lesson can help you have the faith and confidence you need to obey those commandments.

 **8.** Write the following at the bottom of today’s assignments in your scripture study journal:

*I have studied Doctrine and Covenants 38 and completed this lesson on (date).*

*Additional questions, thoughts, and insights I would like to share with my teacher:*

# Doctrine and Covenants 39–40

## Introduction

In January of 1831, a Protestant minister named James Covell (often spelled Covill in Church history records) met with Joseph Smith in Fayette, New York, and “covenanted with the Lord that he would obey any command that the Lord would give to him through . . . His servant [the Prophet Joseph Smith]” (Joseph Smith, in *History of the Church*, 1:143). Joseph then received the revelation recorded in Doctrine and Covenants 39.

In the revelation, the Lord directed James Covell to be baptized and to preach the fulness of the gospel in Ohio. However, the day after the revelation was dictated, James departed from Fayette without explanation. The Lord then gave a revelation to Joseph Smith and Sidney Rigdon, explaining why James had not obeyed the commandment given to him. That revelation is recorded in Doctrine and Covenants 40. (See *Documents, Volume 1: July 1828–June 1831*, vol. 1 of the Documents series of *The Joseph Smith Papers* [2013], 233–37).

## Doctrine and Covenants 39:1–12

*Jesus Christ invites James Covell to receive His gospel and be baptized*

Imagine that you have been given a wonderful gift by a parent or another loved one. Can you think of any reasons why you would choose not to receive the gift?

Read Doctrine and Covenants 39:1–3, looking for a gift Heavenly Father gave His children that some chose not to receive. The Lord uses the phrase “mine own” to refer to the people He ministered unto in mortality, during “the meridian of time.”



The gift these people chose not to receive was Jesus Christ. When we choose to receive the gift of Jesus Christ and His Atonement, we receive many additional blessings and gifts. Read Doctrine and Covenants 39:4,

and identify a gift the Savior said He gives to those who receive Him.

From this verse we learn that **if we receive Jesus Christ, He will give us power to become His children**. Consider marking the words that teach this principle in verse 4.

Read the following statement from President Joseph Fielding Smith to help you better understand what it means to become the sons and daughters of Jesus Christ:

“The Savior becomes our Father, in the sense in which this term is used in the scriptures, because he offers us life, eternal life, through the atonement which he made for us. . . .

“So, we become the children, sons and daughters of Jesus Christ, through our covenants of obedience to him. Because of his divine authority and sacrifice on the cross, we become spiritually begotten sons and daughters, and he is our Father” (*Doctrines of Salvation*, comp. Bruce R. McConkie, 3 vols. [1954–56], 1:29).

### Writing Principles

Writing down the doctrines and principles you identify, or marking them in your scriptures, can help you clarify these truths in your mind. Doing so can also help you understand the focus of the scripture block you are studying.

 **1.** According to what President Smith taught, write in your own words in your scripture study journal how we can become children of Jesus Christ.

As you have already learned, we must choose to receive Jesus Christ before we receive power to become His sons and daughters. Read Doctrine and Covenants 39:5–6, looking for what we must do to receive Him and His power to become His sons and daughters.

Summarize, in your own words, what we must do to become sons and daughters of Jesus Christ: \_\_\_\_\_

As you learned in the introduction to this lesson, the revelation in Doctrine and Covenants 39 was addressed to a Protestant minister named James Covell soon after he had learned about the restored gospel of Jesus Christ and had covenanted to obey any commandment he received through the Prophet Joseph Smith.

 **2.** In your scripture study journal, write how you think the teachings in Doctrine and Covenants 39:1–6 applied to James Covell. Also write your thoughts on how these verses apply to you.

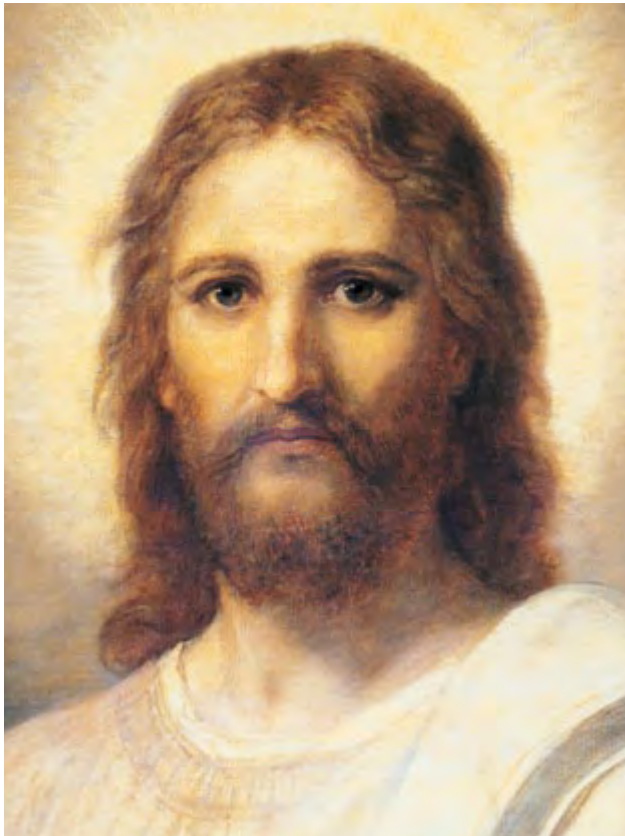

Read Doctrine and Covenants 39:7–9. What did the Lord say about the condition of James Covell’s heart at the time the revelation was given? (You may want to mark the word *now* in verse 8.) What reasons did the Lord give for why James had rejected Him in the past? If you had been in James’s position, how might you have felt after hearing these words? Why?

 3. Copy the following chart in your scripture study journal:

If you will . . .	Then . . .

Read Doctrine and Covenants 39:10–12. As you read, look for what the Lord instructed James Covell to do. Write these instructions under the heading “If you will . . .” on the chart. In addition, look for what the Lord promised James Covell he would receive if he obeyed the Lord. Write these promised blessings under the heading “Then . . .” on the chart.

Consider the blessings the Lord offered James Covell. Although James had been a minister for about 40 years, the Lord offered him the fulness of the gospel, which included responsibilities and blessings he did

not have before, such as the gift of the Holy Ghost and ordination to the priesthood.

Notice the word *if* in Doctrine and Covenants 39:10–11. You may want to mark this word in your scriptures. Ponder the significance of the word *if* in these verses and what the Lord was telling James Covell that he would need to do in order to receive the promised blessings.

From these verses we can learn that **the Lord’s promised blessings are conditional upon our hearkening to His voice.** You may want to write this truth in your scriptures next to Doctrine and Covenants 39:10–11.

 4. Consider some of the blessings the Lord has promised you. In your scripture study journal, write down three of these blessings and what you must do to receive them.

### Doctrine and Covenants 39:13–24

*James Covell is called to preach the fulness of the gospel in Ohio*

Read Doctrine and Covenants 39:13–14, and identify where the Lord called James Covell to preach the gospel.

In Doctrine and Covenants 39:15–24 the Lord gave some instructions to James Covell about what he was to teach. Read Doctrine and Covenants 39:22, and consider how it relates to the principles you have already learned in this revelation.

### Doctrine and Covenants 40

*The Lord reveals why James Covell rejected His words*

The day after the revelation in Doctrine and Covenants 39 was dictated, James Covell left Fayette, New York, without explanation. The Lord revealed to Joseph Smith and Sidney Rigdon why James did not obey His instructions and receive the promised blessings. Read Doctrine and Covenants 40:1–3, looking for why he did not hearken to the voice of the Lord.

Compare Doctrine and Covenants 39:8 and 40:1 to see how James Covell’s heart had changed. You may want to mark the word *was* in Doctrine and Covenants 40:1.

Compare Doctrine and Covenants 39:9 and 40:2. According to those verses, list three reasons why James Covell rejected the word of the Lord: \_\_\_\_\_

\_\_\_\_\_

\_\_\_\_\_



President Joseph Fielding Smith gave further clarification: “[James Covell] was convinced of the truth, for it is clear that the Lord revealed to him things which he and the Lord alone knew to be the truth.

However, when he withdrew from the influence of the Spirit of the Lord and had time to consider the fact that he would lose the fellowship of the world, and his place and position among his associates, he failed and rejected the promises and blessings which the Lord offered him” (*Church History and Modern Revelation*, 2 vols. [1953], 1:174).

What can tempt us to reject God’s words today? You may want to write the following principle in your scriptures by Doctrine and Covenants 40 and in your scripture study journal: ***Fear and the cares of the world can lead us to reject the word of God.***

 **5.** Write in your scripture study journal some fears or cares of the world that might prevent us from following the Lord with all our hearts. Then write what you can do to have faith to overcome these fears or cares of the world and truly receive the Lord.

 **6.** Write the following at the bottom of today’s assignments in your scripture study journal:

*I have studied Doctrine and Covenants 39–40 and completed this lesson on (date).*

*Additional questions, thoughts, and insights I would like to share with my teacher:*

## UNIT 9: DAY 4

# At the Ohio

### Introduction

By the end of January 1831, the Prophet Joseph Smith and his wife, Emma, Sidney Rigdon, and Edward Partridge left New York for Ohio. Most of the other Church members in New York followed during the next five months.

Those Saints who gathered in Ohio were greatly blessed. Continuous revelations through the Prophet Joseph Smith led them to further understanding of the gospel of Jesus Christ. In addition, they received the blessings that came from building a temple and from preaching the gospel. While the Church grew in numbers and spiritual strength in Ohio, severe opposition also increased against the Church and its

leaders. Eventually, in January of 1838, many Church members had to flee Ohio and join the Saints who were living in Missouri. This lesson will give you an overview of the Saints’ experiences in Ohio. You will learn more details regarding these events and teachings in future lessons.

## The Lord Commands the Saints to Gather in Ohio to Receive Promised Blessings

Have you or anyone in your family ever moved to a new home? What were some of the challenges experienced in the move? What blessings have come as a result of the move?

Although the reasons they move may vary, people often make a sacrifice to move somewhere because they believe that life will be better for them in the new place.

Recall from your study of Doctrine and Covenants 37–38 the events surrounding the Lord’s commandment for the Saints to leave New York and move to Ohio. When the Lord commanded them to gather to Ohio, He also promised that they would receive specific blessings there.

 **1.** Copy the following chart into your scripture study journal:

	Promises
D&C 38:31–32	a. b. c. d.
D&C 38:33	e.
D&C 42:61	f.

Read Doctrine and Covenants 38:31–32, and list the four things the Lord said the Saints would receive when they arrived in Ohio in the “Promises” column as answers to *a* through *d*.

Read Doctrine and Covenants 38:33, and list where the Lord said He would send missionaries as the answer to *e* on the chart.

Shortly after Joseph Smith arrived in Ohio, he received the revelation in Doctrine and Covenants 42. Scan Doctrine and Covenants 42:61, and identify the additional promise the Lord gave. Write “*receive revelation upon revelation*” as the answer to *f* on the chart.

The next four sections of this lesson will help you learn more about how the Lord fulfilled these promises as His people gathered to Ohio from 1831 to 1838.





### **"I Will Give unto You My Law" (D&C 38:32)**

The Lord promised that He would give the Saints His law when they gathered to Ohio. Why are laws important? Why do you think laws are important in the Lord's Church?

Read the section introduction to Doctrine and Covenants 42. After the Saints arrived in Ohio in 1831, the Lord fulfilled His promise and gave a revelation referred to as the law of the Church. This law includes commandments and instructions that guide the functions of the Church.

Read the section summary of Doctrine and Covenants 42, looking for some of the laws and commandments the Lord gave to the Saints. (The section summary is located before the first verse. It gives the verse numbers and a brief summary of those verses.) As you read, you may want to mark the phrase "Laws governing the consecration of properties are set forth."

In this revelation, the Lord gave the law of consecration. This law is "a divine principle whereby men and women voluntarily dedicate their time, talents, and material wealth to the establishment and building up of God's kingdom" (Guide to the Scriptures, "Consecrate, Law of Consecration," scriptures.lds.org). Church leaders were commanded to establish the United Firm (also called the United Order) to manage the Church's temporal or business interests, assist the poor, and help eliminate greed from among the Saints. This was a blessing to the Saints at this time because many of the Saints who came from New York were required to leave behind their homes and property. The United Firm also provided money to finance various Church undertakings, such as missionary work and publishing the revelations. You will learn more about the law of consecration and its effect on the Saints in future lessons.

## **“You Shall Be Endowed with Power from on High” (D&C 38:32)**

The Lord also promised to endow the Saints “with power from on high” when they arrived in Ohio (D&C 38:32). An endowment is a gift. Read Doctrine and Covenants 88:119, looking for the commandment the Lord gave to the Saints in Ohio. The “house” referred to in this verse was a temple. The Kirtland Temple, in Kirtland, Ohio, was the first temple built in this dispensation. Read Doctrine and Covenants 95:8, looking for what the Lord said He would endow them with in the temple.

The Kirtland Temple took about three years to build. After it was dedicated in 1836, the Lord began to fulfill His promise to endow the Saints with power, and they experienced marvelous spiritual blessings. For example, the Lord sent three heavenly messengers to the Kirtland Temple—Moses, Elias, and Elijah—to restore vital priesthood keys to the earth. These keys would give the Saints the authority to perform temple ordinances and to seal families of both the living and the dead for eternity. In addition, “the keys of the gathering of Israel” were restored at this time (D&C 110:11). Through these keys, missionaries are given power to teach the gospel throughout the earth.

## **You “Shall Go Forth among All Nations” (D&C 38:33)**

Once the Kirtland Temple had been dedicated and the keys for the gathering of Israel had been restored, the gospel of Jesus Christ began to be preached in more places. Turn to map 3, “The New York, Pennsylvania, and Ohio Area of the USA,” in the Church history maps located in the back of your triple combination. Notice that Kirtland, Ohio, was ideally located to begin to send missionaries throughout the world to teach the gospel “among all nations” (D&C 38:33). Kirtland was near several main transportation routes in the United States. From Kirtland, missionaries only had to travel short distances to access steamboats on America’s major rivers and Lake Erie. They also had access to a national road system to the south and the canal system to the north. Because of this, Kirtland was the point of departure for missions to Canada, other parts of the United States, and Great Britain.

Because of missionary work during this time, the membership in the Church throughout the world increased by thousands. In 1837, Elders Heber C. Kimball and Orson Hyde, along with five others, were called on a mission to Great Britain, where they baptized around 2,000 people. By 1838, when the Saints left Kirtland because of persecution, there were about 2,000 Church members living in Kirtland of the nearly 18,000 Church members worldwide.

## **“Thou Shalt Receive Revelation upon Revelation” (D&C 42:61)**

Turn to the chronological order of contents of the Doctrine and Covenants (located after the introduction) and notice the place where most of the revelations were received.

As you can observe, more revelations were received in Ohio than in any other place. The Lord’s promise that the Saints would receive revelation upon revelation as they gathered to Ohio was fulfilled.

 **2.** Read the section introduction and the section summary to each of the following sections. Then, in your scripture study journal, write a few words summarizing what the revelation is about and a sentence or two describing how the revelation has blessed the Church and your own life.

a. D&C 76

b. D&C 84

c. D&C 89

While the Saints were in Ohio, the Lord also instructed the Prophet Joseph Smith to organize the Church leadership. The First Presidency, the Quorum of the Twelve Apostles, and the Quorum of the Seventy were officially organized during that time. During this same time period, Joseph Smith also continued his work on the translation of the Bible.

## **Opposition and Apostasy Plague the Faithful in Ohio**

Even as the Lord was blessing the Saints in Ohio, opposition against the Church was also increasing. As soon as the Saints arrived in Kirtland, anti-Mormon critics began to attack the Church. Many of the attacks came in the form of defaming newspaper stories and articles.



The Prophet Joseph Smith said the following regarding these publications: “Many false reports, lies, and foolish stories, were published in the newspapers, and circulated in every direction, to prevent people from investigating the work, or embracing the faith” (in *History of the Church*, 1:158).

In spite of these and other difficulties, the Saints continued to gather in Kirtland, particularly during the years 1836–38. In 1836, Joseph Smith felt the burden of debt due to construction costs of the Kirtland Temple. Although the Church owned considerable amounts of land, it also needed cash to repay outstanding loans. Because of the credit needs of the Church and the growing population in Kirtland, Church leaders planned to charter a local bank. Their request to charter a bank was denied by the state of Ohio legislature. Instead of chartering a bank, the Saints formed a company called the Kirtland Safety Society, which functioned as a bank.

In 1837 an economic panic swept through the United States. The whole country felt the effects of the panic and several banks failed. In addition, some of those who were involved with managing the Kirtland Safety Society were not honest in their dealings. The Kirtland Safety Society was also forced to close, and hundreds of individuals who had invested in it lost nearly everything they had invested. Joseph Smith’s losses were greater than anyone else’s. Many Saints accused the Prophet of being responsible for their financial problems, and a number of lawsuits followed. The leaders of the Church who helped create the Kirtland Safety Society had wrongly assumed that individuals had a legal right to organize a private company that engaged in banking activities, and a judgment of \$1,000 was assessed against them for violating Ohio banking laws.

These difficult events led some members of the Church to apostatize. Persecution became so intense during the winter of 1837 and spring of 1838 that most of the Saints were compelled to leave Ohio. Some Church leaders, including Joseph Smith, Sidney Rigdon, and Brigham Young, had to flee Kirtland for the safety of their lives.

 **3.** Based on what you learned in this lesson, write a few sentences in your scripture study journal about how you think you would have felt living in Ohio during this time of Church history. Include what things you would have liked to have been a part of and what things you think would have been a challenge for you.



**4.** Write the following at the bottom of today’s assignments in your scripture study journal:

*I have studied the “At the Ohio” lesson and completed it on (date).*

*Additional questions, thoughts, and insights I would like to share with my teacher:*

## UNIT 10: DAY 1

# Doctrine and Covenants 41

### Introduction

In December 1830 the Lord commanded the Saints in New York to move to Ohio, where they would receive the Lord’s law (see D&C 37:3; 38:32). The Prophet Joseph Smith received the revelation contained in Doctrine and Covenants 41 on February 4, 1831—the day he arrived in Ohio. In this revelation the Lord gave further instructions that would help prepare the Saints to receive His law. In addition, He called Edward Partridge as the Church’s first bishop.

### Doctrine and Covenants 41:1–8

*The Lord describes how to become a disciple of Jesus Christ*

What do you delight in or enjoy doing? What do you think the Lord delights to do? Consider what it means to delight, or find joy, in doing something.

Read Doctrine and Covenants 41:1, looking for what the Lord delights to do. Notice what we must do to receive “the greatest of all blessings” that He desires to give us.

Based on what the Lord said in verse 1, complete the following principle: **The Lord delights to \_\_\_\_\_ as we \_\_\_\_\_.**



**1.** Answer the following questions in your scripture study journal:

- a.** When have you felt that the Lord delighted to bless you because you hearkened to Him?
- b.** What does it mean to you to know that it brings the Lord joy to bless you for hearkening to Him?



The Prophet Joseph Smith obeyed the Lord's counsel to gather to Ohio. Joseph and Emma had already moved seven times in the four years they had been married, and Emma had just recovered from a month-long illness and was six months pregnant when, in late January 1831, they left New York to travel nearly 300 miles by sleigh to Kirtland, Ohio.

When Joseph and Emma arrived in Kirtland, they stopped in front of the Gilbert and Whitney store. "[Joseph] springing up the steps walked into the store and to where the junior partner was standing. 'Newel K. Whitney! Thou art the man!' he exclaimed, extending his hand cordially, as if to an old and familiar acquaintance. 'You have the advantage of me,' replied [Newel K. Whitney], as he mechanically took the proffered hand, 'I could not call you by name as you have me.' 'I am Joseph the Prophet,' said the stranger smiling. 'You've prayed me here, now what do you want of me?'" (in *History of the Church*, 1:146).

Joseph explained that in a vision he had seen Newel praying for him to come to Kirtland. The Whitneys received Joseph and Emma Smith with kindness, and Joseph and Emma lived with them for several weeks (see *History of the Church*, 1:145–46).

Most of the New York Saints moved to Ohio during the five months following the Lord's command to gather there. Some of those Church members did so at a great sacrifice. They sold their property at a loss or simply left their unsold homes and property and went to Ohio to follow the Prophet. Read the following account and look for an example of how the Lord blessed these Saints for hearkening to His command to move to Ohio at this time:

The Prophet Joseph Smith's mother, Lucy Mack Smith, led a group of 80 Church members from Fayette, New York, to Ohio. As they traveled by boat on the Cayuga



and Seneca Canal to Buffalo, New York, Lucy reminded the Saints that they "were traveling by commandment of the Lord, as much as Father Lehi was, when he left Jerusalem; and, if faithful, [they] had the same reasons to expect the blessings of God" (*History of Joseph Smith by His Mother*, ed. Preston Nibley [1958], 196).

When they arrived in Buffalo, New York, they met Church members from Colesville who were also on their way to Ohio and who had been stranded in Buffalo for one week already. The canal passage was blocked by ice "piled up to the height of twenty feet," and they were told they may need to "remain in the harbor at least two weeks longer." Many of the Saints in Lucy's group became discouraged. They were hungry, and some of the children had become sick. They took deck passage on another boat, put their things on board, and Lucy Smith found temporary shelter for the women and their sick children until early the next morning. (See *History of Joseph Smith by His Mother*, 199–202.)

When they were back on board, Lucy testified to her group, "Now, brethren and sisters, if you will all of you raise your desires to heaven, that the ice may be broken up, and we be set at liberty, as sure as the Lord lives, it will be done." And she described what happened next: "At that instant a noise was heard, like bursting thunder. The captain cried, 'Every man to his post.' The ice parted, leaving barely a passage for the boat, and so narrow that as the boat passed through the buckets of the waterwheel were torn off with a crash. . . . We had barely passed through the avenue when the ice closed together again, and the Colesville brethren were left in Buffalo, unable to follow us" (*History of Joseph Smith by His Mother*, 204–5).

 **2.** From the account you read of the group of Saints led by Lucy Mack Smith, summarize in your scripture study journal how these Saints showed their faith in the Lord. Also write about how their experience during this difficult situation shows that the Lord is aware of us and will help us overcome challenges as we hearken to Him.

Read Doctrine and Covenants 41:2–4, and identify the commandment and instructions the Lord gave the people. In the following list, draw a line through the instructions the Saints were *not* commanded to follow:

- Assemble to agree upon the word of God.
- Receive the law by the prayer of faith.
- See that the law is kept.
- Gather to Jackson County, Missouri.

In Doctrine and Covenants 41:3, mark the purpose of the law the people were to receive "by the prayer of [their] faith." This law the Lord referred to is found in Doctrine and Covenants 42. You will study this law in detail in the next few lessons.

 **3.** In your scripture study journal, describe how you think receiving God's laws and commandments is a blessing. In addition, explain how God's laws help us to "have all things right before [Him]" (D&C 41:3).



Think about how the following two concepts could be similar and how they might be different:

Believer	Disciple
----------	----------

Read Doctrine and Covenants 41:5, and complete the following principle: **We become disciples of Jesus Christ as we** \_\_\_\_\_

Is there a difference between believing the laws of Jesus Christ and receiving them? While believing God's laws is an important part of becoming a disciple of Jesus Christ, our receiving His laws—accepting and obeying them—builds our faith in the Savior.

 **4.** To help you apply the principle that we become disciples of Jesus Christ as we receive and live His laws, select and read about one of the standards from the *For the Strength of Youth* booklet. Then, in your scripture study journal, write what you would like to do to receive and live that standard a little better.

In Doctrine and Covenants 41:7 the Lord instructed the Saints to provide a home for Joseph Smith and his family to live in and in which he could continue translating the Bible. The Saints followed these instructions, and a small home was built where Joseph and Emma lived for a few months.

## Doctrine and Covenants 41:9–12

*The Lord calls Edward Partridge to be the first bishop of the Church*

Imagine that your ward needed a new bishop. Search Doctrine and Covenants 41:9, and mark any words or phrases that teach the following principle: **Bishops are called of God, sustained by the voice of the members, and ordained by the proper authority.**

The phrase “appointed by the voice of the church” means the members of the Church have sustained the person who has been called of God. The phrase “to spend all his time in the labors of the church” was directed specifically to Edward Partridge, and it also applies to members of the Presiding Bishopric today. It does not apply to bishops of wards, who continue their normal employment while they serve in the Church.

 **5.** In your scripture study journal, write why it is important to you to know your bishop or branch president has been called of God and ordained by the proper priesthood authority.

Read Doctrine and Covenants 41:11, looking for attributes the Lord said that Edward Partridge had that might have helped him in his calling as bishop. You may want to write a note in your scriptures that the word *guile* refers to deceit or hypocrisy. Therefore, Edward was an honest man of integrity.

 **6.** Read Doctrine and Covenants 41:12, looking for the Lord's warning. Then answer the following questions in your scripture study journal:

- What do you think it means to beware how we “hold” the Lord's words?
- How might being aware of what you do with the Lord's words relate to what you have learned about being a disciple of Jesus Christ?



As you read the following statement from Elder Neal A. Maxwell of the Quorum of the Twelve Apostles, consider how it relates to what you have learned about discipleship in this lesson: “Each day we decide the degree of our discipleship. Each day we answer the question, ‘Who’s on the Lord’s side? Who?’” (“My Servant Joseph,” *Ensign*, May 1992, 39).

 **7.** Write the following at the bottom of today's assignments in your scripture study journal:

*I have studied Doctrine and Covenants 41 and completed this lesson on (date).*

*Additional questions, thoughts, and insights I would like to share with my teacher:*

## UNIT 10: DAY 2

# Doctrine and Covenants 42:1–29

## Introduction

On February 9, 1831, shortly after arriving in Kirtland, Ohio, the Prophet Joseph Smith received a revelation that now comprises Doctrine and Covenants 42:1–72. He received further instruction on February 23 (see D&C 42:73–93). Taken together, these revelations are known as “the law of the Church” (see D&C 42 section introduction). Doctrine and Covenants 42 is divided into two lessons. This lesson covers verses 1–29, which provide instruction on teaching the gospel and set forth general laws of conduct for members of the Church.

## Doctrine and Covenants 42:1–10

*The Lord calls upon the elders to teach the gospel and build up His Church*

Circle the words below that you think apply to God’s laws and commandments:

Restriction	Blessing	Hard	Control
Gift	Limit	Reward	Freedom

Why do we sometimes view God’s laws and commandments in a negative way? Why is it important to understand that each of His laws and commandments is a gift or a blessing? How does obedience to God’s laws and commandments free us from the consequences of sin?

As you study today’s lesson, look for how the early Saints felt about receiving God’s laws and ponder your own attitude toward the commandments.

The Lord commanded the Saints in New York to go to Ohio and promised that He would give them His law after they arrived there (see D&C 38:32). Through great sacrifice, they left their homes and possessions and obeyed the command to gather to Ohio. Most of the Saints in New York obeyed the command to gather to Ohio. After some of them had arrived in Kirtland, 12 elders met with the Prophet Joseph Smith and called upon the Lord. Read Doctrine and Covenants 42:1–3, looking for why the elders of the Church had assembled.

These elders had assembled, as they had been commanded, so that the Lord could give them His law. The Lord’s first instruction to them was to go forth as missionaries, two by two, to spread the gospel and build up the Church in every region to which they were called until all the people are gathered as one (see D&C 42:4–10).

## Doctrine and Covenants 42:11–17

*The Lord sets forth principles of teaching the gospel*

Imagine that you are sitting in the chapel waiting for sacrament meeting to begin. None of the members of the bishopric or branch presidency are present. Someone from the congregation gets up and explains that he would like to extend a few callings and teach some new doctrine that has been revealed to him. What would be your reaction in this situation? Why?

Read Doctrine and Covenants 42:11, and identify what is needed before someone can preach the gospel or build up the Church as an official representative of the

Church. This instruction regarding ordination applies not only to missionaries but also to any who are set apart to teach and lead in the Church. You may want to mark the words or phrases in this verse that teach the following principle: **Those who teach and build up the Church must be called of God and ordained or set apart by the authorized leaders of the Church.**

Think about how the practice of publically announcing and sustaining Church leaders and members in their callings fulfills the Lord’s directive that their authority “is known to the church” (D&C 42:11; see D&C 28:13). How does this provide order to the Church and keep us safe from deception?

Read Doctrine and Covenants 42:12–13, and mark the responsibilities given to people who teach and lead in the Church.



1. Answer the following questions in your scripture study journal:

- According to Doctrine and Covenants 42:12, *what are teachers in the Church to teach?*
- According to verse 13, *how are they to teach?*



2. Notice the phrase “observe the covenants and church articles to do them” in Doctrine and Covenants 42:13. In your scripture study journal, write about why it is important for teachers and leaders to live what they teach. How has your life or the life of someone you know been blessed when a teacher or leader has lived by the doctrines and principles he or she has taught?

Read Doctrine and Covenants 42:14, and identify what those who teach should do to obtain the Spirit’s direction. Then complete the following principle: **If we \_\_\_\_\_, we can receive the Spirit to help us teach others.** (You may want to mark the words in that verse that teach the principle or write the principle in the margin of your scriptures.)

Another principle taught in Doctrine and Covenants 42:14 is **if we do not have the Spirit, we will not teach.**

To help you understand why it is important to have the Spirit as you learn and teach the gospel, read Doctrine and Covenants 42:16–17, and identify what the Holy Ghost knows and does. The term *Comforter* used in these verses is one of the names of the Holy Ghost. In the spaces provided, complete the following doctrinal teaching from verse 17: **The Holy Ghost knows \_\_\_\_\_ and bears record of \_\_\_\_\_.**

Based on this truth, how can the Holy Ghost help you as you teach?

Because the Holy Ghost knows all things, He knows what all of us have experienced and need in our lives. Those who teach, testify of, or explain the truths of the gospel through the inspiration of the Holy Ghost can be guided to help others receive what the Lord knows they need.

 **3.** In your scripture study journal, describe a time when you felt the Holy Ghost’s influence as you were teaching, sharing, explaining, or testifying of the gospel. Also write about an experience when you felt the Holy Ghost bear testimony to you of Heavenly Father and Jesus Christ. If you are not sure if you have had these types of experiences, ask a family member or friend about experiences when he or she has felt the influence of the Holy Ghost and write about what you learn from that person’s account.

### Doctrine and Covenants 42:18–29

*The Lord gives laws and commandments for the members of the Church*

After the Lord gave instructions about teaching in the Church, He revealed laws and commandments that apply to all members of the Church. Read Doctrine and Covenants 42:18–29, and identify the commandments taught in those verses. You may want to mark what you find.

Although verse 19 states that “he that killeth shall die,” verse 79 helps us understand that murderers should be turned over to civil authorities “and dealt with according to the laws of the land.”

In Doctrine and Covenants 42:20–28, to be “cast out” means to be excommunicated, or to lose one’s membership in the Church. While these verses teach that excommunication is for those who will not repent, the consequences of excommunication for certain serious sins may be part of the repentance process for some humble, repentant people who are seeking forgiveness of their sins. Disciplinary action in the Church is to protect the Church and to help those who sin repent and receive the blessings of the Savior’s Atonement.

 **4.** To deepen your understanding of some of the principles taught in Doctrine and Covenants 42:18–29, answer the following questions in your scripture study journal:

- a. Why do you think people today are tempted to steal? What do you think might help a person who often is tempted to steal?
- b. One form of lying is cheating. Why do you think lying and cheating are serious sins?
- c. Thinking of experiences you have had, why is speaking evil of others wrong and harmful?

Review Doctrine and Covenants 42:22–23, and mark the words that teach this principle: **If we lust after another person, then we deny the faith and lose the Spirit.**

Lust is not love. Those who lust after others are selfishly concerned with their own gratification.

They view others as objects and lack self-control. Lust distorts and changes the way you see others. It causes you to lose the guidance of the Spirit and can damage your ability to have a normal relationship with others, especially your future spouse. It limits your ability to feel true love. Lusting shows a lack of faith in God and goes against the way He expects us to view others.



One tool of lust prevalent in our day is pornography. Elder Dallin H. Oaks of the Quorum of the Twelve Apostles warned:

“Pornography impairs one’s ability to enjoy a normal emotional, romantic, and spiritual relationship with a person of the opposite sex. . . .

“Pornography is also addictive. It impairs decision-making capacities and it ‘hooks’ its users, drawing them back obsessively for more and more. . . .

“Do all that you can to avoid pornography. If you ever find yourself in its presence—which can happen to anyone in the world in which we live—follow the example of Joseph of Egypt. When temptation caught him in her grip, he left temptation and ‘got him out’ (Genesis 39:12).

“Don’t accommodate any degree of temptation. Prevent sin and avoid having to deal with its inevitable destruction. So turn it off! Look away! Avoid it at all costs. Direct your thoughts in wholesome paths. . . .

“. . . Do not patronize pornography. Do not use your purchasing power to support moral degradation. And young women, please understand that if you dress immodestly, you are magnifying this problem by becoming pornography to some of the men who see you” (“Pornography,” *Ensign* or *Liahona*, May 2005, 89–90).

#### Cause and Effect

To help you identify gospel principles in the scriptures, look for if–then and because–therefore relationships. Try using this skill with Doctrine and Covenants 42:23.

 **5.** In your scripture study journal, write a paragraph describing what you can do to strengthen yourself against the temptation to lust. Include in your paragraph reasons why you think this commandment is important. (You may want to study the topic “Chastity” in *True to the Faith: A Gospel Reference* [2004] for additional ideas.)

To conclude this lesson, read Doctrine and Covenants 42:29 and identify the principle taught in this verse.

 **6.** In your scripture study journal, write how you think keeping God’s laws and commandments shows your love for Him. How has keeping the commandments brought you closer to God?

During the next week, demonstrate more love for God by striving to be more obedient to one of His laws or commandments.

 **7.** Write the following at the bottom of today’s assignments in your scripture study journal:

*I have studied Doctrine and Covenants 42:1–29 and completed this lesson on (date).*

*Additional questions, thoughts, and insights I would like to share with my teacher:*

## UNIT 10: DAY 3

# Doctrine and Covenants 42:30–93

### Introduction

As you read in the introduction to the day 2 lesson, the Prophet Joseph Smith received the revelation in Doctrine and Covenants 42 “in fulfillment of the Lord’s promise previously made that the ‘law’ would be given in Ohio” (D&C 42 section introduction). In this second lesson on Doctrine and Covenants 42, covering verses 30–93, you will learn that the Lord introduced temporal, economic, and spiritual laws directing Church members to help the poor, finance various Church undertakings, and assist other Saints who came to Ohio.

## Doctrine and Covenants 42:30–42

### *The Lord sets forth the law of consecration*

Doctrine and Covenants 42:30–42 contains the Lord’s law of consecration. To help you learn about and understand this law, your assignment is to prepare a lesson and teach a family member or a friend about the law of consecration given in these verses. There will be an opportunity to record your experience in your scripture study journal later in today’s lesson.

To prepare to teach the lesson, read Doctrine and Covenants 42:30–42, and then do the following:

- Use tape or a marker to make a line on six drinking glasses. (Use clear drinking glasses if possible.) Mark the lines at different heights on each of the glasses. Then hide or cover the glasses so the person you are teaching doesn’t see them.
- Obtain a pitcher with more than enough water in it to fill all of the glasses to the lines marked on them. (If available, you could put coloring in the water.)

Show the pitcher to the person you are teaching, and tell him or her that the water represents all of the wealth and resources in a community. Explain that in February 1831, members of the Church in Kirtland, Ohio, needed to help care for the poor, assist new settlers who were sacrificing much to gather in Ohio, and help finance Church operations.

Ask your student to read Doctrine and Covenants 42:30 aloud and look for what the Lord revealed regarding the poor. Ask him or her to mark the word *consecrate*.



Read the following definition of the word *consecrate* given by Elder D. Todd Christofferson of the Quorum of the Twelve Apostles: “To consecrate is to set apart or dedicate something as sacred, devoted to holy purposes” (“Reflections on a Consecrated Life,” *Ensign* or *Liahona*, Nov. 2010, 16).

You may want to invite your student to write this definition in the margin of his or her scriptures next to verse 30.



Explain that Doctrine and Covenants 42 contains principles of a law called the law of consecration. To help your student understand these basic principles, you may want to read aloud the following explanation by President J. Reuben Clark Jr. of the First Presidency:



“The basic principle of [the law of consecration] is that everything we have belongs to the Lord; therefore, the Lord may call upon us for any and all of the property which we have, because it belongs to Him”

(in Conference Report, Oct. 1942, 55).

Ask your student to summarize what Doctrine and Covenants 42:30 teaches about our responsibility toward the poor and those in need. (Your student may answer with something similar to the following principle: **We are to care for the poor and those in need.** Encourage him or her to mark words or phrases in that verse that teach this principle.)

Reveal the empty glasses with the marks on them, and begin to fill them with the water from the pitcher. Fill one glass to the line you made on it, fill three glasses with water above the lines you made, and fill two below the lines you marked. Explain that the lines on each glass represent the needs and righteous desires of various families. For example, the needs of a family with one child may be different from the needs of a family with five children. Explain that the water represents each family’s wealth and resources. The glasses with water below the line represent families that do not have enough money or goods to support their needs.

Read Doctrine and Covenants 42:31 aloud, and invite your student to follow along in his or her scriptures. Then ask the following questions:

- For these Saints, what was the first step in living the law of consecration? (To give their substance—their money, goods, and properties—to the bishop.)
- When we give to the poor, to whom are we also giving? (The Lord.)

To represent Church members consecrating their properties to the Church, pour all of the water in the glasses back into the pitcher.

Invite your student to read Doctrine and Covenants 42:32 aloud, looking for the second step in living the law of consecration. Then ask:

- What was the second step in living the law of consecration? (Every family received from the bishop a portion of the resources according to what was needed.)

Explain that after giving, or consecrating, their property to the Church, the families were given property back according to their needs. This portion became the family’s own property. The families were stewards over the property, and they were allowed to use it as they saw fit, but they were accountable to God for its use.

Pour water from the pitcher, and fill each glass to its line. Explain that under the law of consecration, each family received according to the family’s needs and righteous desires. These decisions were made by the bishop and the head of the family counseling together. The families recognized that their ownership of the property was a gift from the Lord, and as stewards over it, they were accountable to use what they had been given to help build the Lord’s kingdom.

Point out the water remaining in the pitcher. Invite your student to read Doctrine and Covenants 42:33–35 aloud and look for what the “residue” or remainder of the consecrated property was for. Then ask the following questions:

- What did the Lord instruct the Saints to do with the leftover property, or the “residue”? (They were to use it to help the poor, finance Church buildings, and help members who were in need.)
- From what you learn in verse 34, what do you think the pitcher represents? (The storehouse.)

Invite your student to read Doctrine and Covenants 42:38 aloud and look for a truth that would help individuals desire to live the law of consecration, no matter their circumstances. Then ask:

- What principle did the Lord teach regarding doing good to others? (The response should be something similar to the following principle: **As we do good unto others, we do it unto the Lord.** Consider asking your student to mark this truth in his or her scriptures.)

- How might this truth have helped the Saints be willing to consecrate their properties? How can remembering this principle help you in your life?
- When have you felt that you were serving the Lord when you did something to help others?



Explain that although we are not commanded to live the law of consecration in the same manner as the early Saints, the law is still in force today. Read the following statement from President

Spencer W. Kimball aloud, and ask your student to listen for what it means for us today to live the law of consecration: “Consecration is the giving of one’s time, talents, and means to care for those in need—whether spiritually or temporally—and in building the Lord’s kingdom” (“Welfare Services: The Gospel in Action,” *Ensign*, Nov. 1977, 78).

You may want to encourage your student to write this definition in the margin of his or her scriptures near verse 30. After you have read the statement from President Kimball, ask:

- What time, talents, and means do you have that you could use to help those who are in need?

Share an experience about a time when you were blessed by someone who gave up time, talents, or means to help you. Share your testimony of the importance of doing good to others. When you are finished, be sure to thank your student for participating in your lesson.



**1.** In your scripture study journal, write the name of the person you taught, along with the date you completed this assignment. Write a description of what you thought went well in your teaching experience and what was difficult. In addition, describe how you have felt blessed when you have lived the principle that **as we do good unto others, we do it unto the Lord.**

## Doctrine and Covenants 42:43–55

### *The Lord gives counsel concerning death and healing*

In Doctrine and Covenants 42:43–55 the Lord taught about death and healing. He explained that death is sweet unto those who die in Him but bitter to those who do not. He also said that those who are sick should “be nourished with all tenderness” (D&C 42:43) and receive

a priesthood blessing. Some will be healed through their faith in Jesus Christ (see D&C 42:48).

## Doctrine and Covenants 42:56–69

### *The Lord promises to reveal additional scripture and revelation to Joseph Smith*

In Doctrine and Covenants 42:56–69, the Prophet Joseph Smith learned that the Lord would continue to give revelation as he continued to seek for it. Read Doctrine and Covenants 42:61, and identify a principle about receiving revelation. Our leaders today lead and guide the Church by the principle of continuing revelation.



**2.** In your scripture study journal, write an if-then statement of a principle you learn from verse 61.

## Doctrine and Covenants 42:70–87

### *Priesthood leaders receive instruction on dealing with Church members who commit serious sin*

Doctrine and Covenants 42:70–87 contains some basic principles and laws governing Church discipline. Read Doctrine and Covenants 42:78, and mark the Lord’s commandment to every member of the Church.

## Doctrine and Covenants 42:88–93

### *The Lord instructs the Saints on how to resolve personal offenses*

Think of a time when you have seen someone take offense at the words or actions of another person. Read Doctrine and Covenants 42:88–89, looking for the Lord’s instructions on what we should do if someone has offended us.



**3.** Answer the following questions in your scripture study journal:

- What is the first thing we should do if someone has offended us?
- Why do you think this approach might be helpful?

In Doctrine and Covenants 42:90–91 we learn that some sins or offenses that are publically known require an appropriate public confession or chastisement. In Doctrine and Covenants 42:92–93 we learn the following principle: **Offenses given in private should be resolved in private.**



**4.** In your scripture study journal, describe why you think it is best that private offenses be resolved privately.

It takes courage to approach someone who has offended you. Pray for help from Heavenly Father as you seek to appropriately resolve any bad feelings you may have about others.

 **5.** Write the following at the bottom of today's assignments in your scripture study journal:

*I have studied Doctrine and Covenants 42:30–93 and completed this lesson on (date).*

*Additional questions, thoughts, and insights I would like to share with my teacher:*

## UNIT 10: DAY 4

# Doctrine and Covenants 43–44

## Introduction

As recorded in Doctrine and Covenants 43, in February 1831 the Lord instructed Church members about the unique role of the prophet in receiving revelation for the Church, as well as the need for the elders of the Church to preach repentance in preparation for future events. Doctrine and Covenants 44 contains the Lord's instructions for elders of the Church to assemble together in a conference.

## Doctrine and Covenants 43:1–7

*The Lord declares that revelations and commandments come only through His appointed prophet*

Imagine two different people trying to lead you in singing two different songs at the same time. Would you be able to sing both songs simultaneously? How would you choose which music leader to follow?

In February 1831, a recent convert in Kirtland, Ohio, referred to as Mrs. Hubble, claimed to receive revelations and commandments for the Church. Some Church members were deceived by her claims. The Prophet Joseph Smith inquired of the Lord concerning Mrs. Hubble's claims, and in response he received the revelation now recorded in Doctrine and Covenants 43.

Read Doctrine and Covenants 43:1–5, looking for who the Lord said would receive revelation for the entire Church.

These verses helped early Church members understand that only the Prophet Joseph Smith had the authority to receive commandments and revelations for the entire Church. These verses also help us to understand that **only the President of the Church will receive revelations for the entire Church**. You may want to write this doctrine in your scriptures by Doctrine and Covenants 43:3–4 or in your scripture study journal.

 **1.** Answer the following question in your scripture study journal: Why is it important to know that only the President of the Church (or the First Presidency) will receive revelations for the entire Church?

Just as Mrs. Hubble and others made false claims that deceived some of the Saints in the early days of the Church, there are pretenders or deceivers today who promote false ideas. Read Doctrine and Covenants 43:5–7, and identify the pattern the Lord revealed to help us not be deceived by individuals who promote false ideas or claim to receive revelation for others but do not have the authority to do so.

In the space provided, describe the pattern the Lord revealed to protect us from being deceived today:



The following statement from President Joseph Fielding Smith helps us understand that to “come in at the gate” (D&C 43:7) is to do something the proper and authorized way: “The Lord would have us know that he does all things in order, and whenever

he calls one to lead the Church, that one will come in at the gate and be ordained by those who hold authority. It has been so from the beginning and will continue so to the end” (*Church History and Modern Revelation*, 2 vols. [1953], 1:138). To “come in at the gate” is to enter by the accepted and known way.

## Doctrine and Covenants 43:8–16

*The elders are commanded to assemble to instruct, edify, and be sanctified*

 **2.** Make a list in your scripture study journal of the various meetings you attend as a member of the Church. Next to each meeting, write what you think its purpose is.

Read Doctrine and Covenants 43:8, and mark words or phrases that teach the following principle: **When we assemble together, we are to instruct and edify one another so we can learn how to act and direct the Church.** The commandment to edify each other

means we are to build up and strengthen each other spiritually. The phrase “direct my church” in this verse refers to the Church members being instructed on how to perform their duties. Meetings are held to help Church members keep their covenants and magnify their callings, which means to perform the responsibilities of their callings.

 **3.** In your scripture study journal, write about an experience in which you felt edified—built up and strengthened spiritually—as you attended a Church meeting.

Read Doctrine and Covenants 43:9–11, and identify what we are to do after we learn the Lord’s laws and commandments. In verse 9, the phrase “be sanctified”

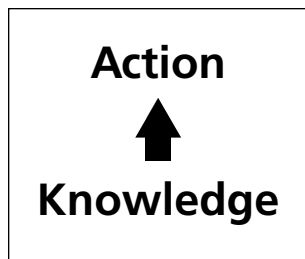

means to be made holy, or cleansed from the sins of the world. One truth we learn from verse 9 is that **we are to bind ourselves to act on the truths we learn.** (You may want to write this principle in your scriptures.)

 **4.** Answer the following questions in your scripture study journal:

- How does acting on what we learn in Church meetings help us become sanctified?
- What role do you think baptism and the sacrament have in our becoming sanctified?
- When have you committed to act on what you learned in a Church meeting and then followed through by doing it? How were you blessed for doing so?

In Doctrine and Covenants 43:12–14, the Lord told the Saints that they would receive the glories of His kingdom if they would sustain His prophet.

### Evaluating Our Lives

When we take the time to honestly evaluate how well we are living a certain gospel principle, we give the Holy Ghost the opportunity to help us realize what we are doing well and how we can improve. As you evaluate yourself, try to seek the guidance of the Holy Spirit and be completely honest.

### Doctrine and Covenants 43:17–35

*God’s servants are to preach repentance in preparation for the Second Coming and the Millennium*

Think of an activity or event that requires much careful preparation, such as a full-time mission, sporting event, musical production, teaching assignment, or test.

How do you think a person would feel if he or she was not prepared when the time came to participate in the activity or event?

Read Doctrine and Covenants 43:17–22, looking for an event that requires careful preparation.

The Lord instructed the elders to tell all nations to prepare for the Second Coming of Jesus Christ. From what you learn in Doctrine and Covenants 43:20, fill in the blanks with the appropriate words that complete this principle: **We need to repent and \_\_\_\_\_ ourselves for the Second Coming of Jesus Christ.**

Read Doctrine and Covenants 43:25–28, looking for some of the ways in which the Lord calls all people to repent and be saved. Why do you think the Lord uses so many voices to warn us?

Read Doctrine and Covenants 43:29–31, looking for what will happen after the Second Coming of Jesus Christ.

You may want to mark the words or phrases that teach that **during the Millennium, Satan will be bound and Jesus Christ will reign with His people on the earth.**



President George Q. Cannon of the First Presidency explained how Satan will be bound during the Millennium: “We talk about Satan being bound. Satan will be bound by the power of God; but he will be bound also by the determination of the people of God not to listen to him, not to be governed by him” (*Gospel Truth: Discourses and Writings of President George Q. Cannon*, sel. Jerreld L. Newquist, 2 vols. [1957–74], 1:86).

The Prophet Joseph Smith taught: “Christ and the resurrected Saints will reign over the earth during the thousand years. They will not probably dwell upon the earth, but will visit it when they please, or when it is necessary to govern it” (in *History of the Church*, 5:212).

 **5.** Ponder specifically what you may need to do to repent and prepare for the Second Coming of Jesus Christ and the Millennium. Because of the personal nature of this assignment, write *Finished assignment 5* in your scripture study journal when you have completed this assignment.



## Doctrine and Covenants 44

*The Lord commands His servants to assemble together*



In the Conference Center, in Salt Lake City, Utah, and in other buildings throughout the world, Church members gather every six months to hear the General Authorities and other Church leaders speak.

In Doctrine and Covenants 44, the Lord directed the elders of the Church to gather for a conference. This would be the fourth general conference of the Church and the first conference held in Kirtland, Ohio. Study Doctrine and Covenants 44:1–4, looking for reasons why the Lord commanded the Saints to hold this conference.

Fill in the blanks in the following statements, using what you have learned from these verses: The Lord commanded the elders of His Church to \_\_\_\_\_.  
At the conference the Lord promised to \_\_\_\_\_.

After the conference, the elders were to \_\_\_\_\_.

As a result, many people would \_\_\_\_\_.

As you conclude this lesson, think again about what you will do to act on the principles you have learned. The Lord will bless you as you act on these truths.



**6.** Write the following at the bottom of today's assignments in your scripture study journal:

*I have studied Doctrine and Covenants 43–44 and completed this lesson on (date).*

*Additional questions, thoughts, and insights I would like to share with my teacher:*

## UNIT 11: DAY 1

# Doctrine and Covenants 45:1–15

## Introduction

The Church continued to grow in Kirtland, Ohio, and opposition to and false reports about the Church also increased. The revelation found in Doctrine and Covenants 45, received in March 1831, brought joy to the Saints as they dealt with local prejudices. You will study Doctrine and Covenants 45 in two lessons. In the first part of this revelation, Jesus Christ testified of His role as the Son of God. He also spoke of the city of Enoch.

## Doctrine and Covenants 45:1–5

*Jesus Christ testifies of His role as the Son of God*

Who do you go to for advice when you are faced with a challenge or a difficult decision? What qualities does that person have that give you the confidence to share your feelings and listen to his or her counsel?

We are more likely to listen to someone who we feel cares about us personally and who has had success in the subject about which he or she is offering advice. The revelation recorded in Doctrine and Covenants 45 came at a time when Latter-day Saints and others were hearing and reading conflicting messages about the Church. Read the section introduction of Doctrine and Covenants 45 and look for what circumstances the Saints were facing when the Lord gave them this revelation.

Notice the word *hearken* in Doctrine and Covenants 45:1. You might want to mark it. To hearken to someone means to listen attentively; it can also include both listening and obeying. When we truly hearken to the Lord, we will follow His counsel and commandments. At the beginning of this revelation, the Lord made declarations about some of His roles and about His efforts to help us. As we read these declarations, we can find reasons to hearken to His words. Watch for the words *hearken* and *listen* in the verses studied in today's lesson.

Read Doctrine and Covenants 45:1, looking for what Jesus Christ said about Himself. You may want to mark what you find.

How does recognizing Jesus Christ as the Creator of this earth to which we have been sent help us to hearken to the things He says?

Read Doctrine and Covenants 45:2–3, and identify additional reasons to hearken to the Savior. Notice the sense of urgency in verse 2. We should listen to the Savior while there is time to do what He says.

Doctrine and Covenants 45:3 teaches us that **Jesus Christ is our advocate with our Father in Heaven**. Notice the word *is* in Doctrine and Covenants 45:3. Do you understand the difference between saying “Jesus Christ *will be* our advocate” and “Jesus Christ *is* our advocate”? The Savior not only pleads our cause at the Final Judgment but stands as our Advocate every day as we pray to Heavenly Father, repent, and seek to have the Spirit with us. Ponder in what ways you need Jesus Christ to be your Advocate in your everyday life.

To help you understand the word *advocate* and the relationship of an advocate to an accused person, draw a line matching the roles of persons on the left with the correct meaning on right.

Defendant	This person is believed to have committed a crime.
Judge	This person pleads the cause of someone else.
Advocate	This person hears evidence and determines consequences according to law.

Imagine you are guilty of breaking a law and have been brought to stand before a judge. How would you feel? Why would you be grateful for an advocate to plead your cause for you?

 **1.** Read Doctrine and Covenants 45:4–5, looking for how Jesus Christ fulfills His role as our Advocate and pleads for our salvation. Then answer the following questions in your scripture study journal:

- Why is Jesus Christ qualified to be our Advocate?
- What was the Savior asking Heavenly Father to consider?



Elder D. Todd Christofferson of the Quorum of the Twelve Apostles testified of the Savior’s interest in our current situations as well as our Final Judgment: “I am particularly gratified, and it is of great significance to me, that I may at any moment and in any circumstance approach through prayer the throne of grace, that my Heavenly Father

will hear my petition, that my Advocate, him who did no sin, whose blood was shed, will plead my cause. (See D&C 45:3–5.) I rely heavily on that access to God, which he gives to all his children, for he is indeed no respecter of persons, and he that asks shall receive” (“I Know in Whom I Have Trusted,” *Ensign*, May 1993, 83).

The way Jesus Christ pleads for us is different than an advocate in a court representing man’s law because He has already paid the penalty for sin.

 **2.** Answer the following questions in your scripture study journal:

- How do you feel about Jesus Christ being your Advocate and not only pleading your cause but paying the penalty for your sins?
- What do you feel the Savior wants you to do to better come unto Him and accept Him as your Advocate?

## Doctrine and Covenants 45:6–10

*The Savior invites all to come unto His everlasting covenant*

Study Doctrine and Covenants 45:6–10, looking for reasons the Savior gave for us to hearken to Him.

The Lord’s everlasting covenant spoken of in verses 9–10 is “the fulness of the gospel of Jesus Christ. . . . It is everlasting in the sense that it is God’s covenant and has been enjoyed in every gospel dispensation where people have been willing to receive it” (Guide to the Scriptures, “New and Everlasting Covenant,” scriptures.lds.org).

Notice in Doctrine and Covenants 45:9 that Jesus Christ sent His everlasting covenant “to be a light to the world, and to be a standard for [His] people, . . . and to be a messenger before [His] face to prepare the way before [Him].”

 **3.** Answer the following questions in your scripture study journal:

- What do you think it means to “come . . . unto” the everlasting covenant (D&C 45:10)?
- In what ways have you seen the gospel be a light or a standard to others?
- In what way does the everlasting covenant, or the fulness of the gospel of Jesus Christ, help prepare the way for the Lord’s coming?

## Doctrine and Covenants 45:11–15

### *The Savior speaks of Enoch and his people*

Read Doctrine and Covenants 45:11, looking for what the Lord will share with those who hearken to His voice.



The Lord said that some people call Him “the God of Enoch” (D&C 45:11). Enoch was a great prophet who lived before the time of Noah and the Flood. The earth in Enoch’s day was covered in wickedness, just as it will be at the time of the Savior’s Second Coming, but Enoch led a society of righteous people who lived in a city called Zion. The inhabitants of Zion were eventually “separated from the earth,” or taken into heaven because of their righteousness (see D&C 45:12; Moses 7:69).

Read Doctrine and Covenants 45:12, looking for what the city of Zion is being reserved for.

Doctrine and Covenants 45:12–14 teaches us that the Lord has received the people of the city of Zion unto Himself and that He will reserve them “until a day of righteousness shall come.” At that time Enoch and his people will return to the earth to meet the Lord’s people in the city of New Jerusalem, which will also be called Zion (see Moses 7:62–64). All prophets have looked forward to that day. Because of the wickedness

of the people on the earth, that day has not yet come, but the holy men who have looked forward to it will someday see it.

 **4.** Read Doctrine and Covenants 45:15. Then look back through Doctrine and Covenants 45:1–14 and ponder upon one of the Savior’s roles or characteristics that helps you to want to hearken to His voice. Explain in your scripture study journal why that role or characteristic helps you desire to hearken to the Savior’s voice.

One principle we can learn from these opening verses in Doctrine and Covenants 45 is that **learning about the Savior and what He has done for us can increase our desire to hearken to His voice.** The Lord introduced Himself and invited the Saints to hearken to His voice because of the importance of the rest of Doctrine and Covenants 45.

Read Doctrine and Covenants 45:15–16, looking for what the Lord said He would speak and prophesy of. How can you prepare yourself to hearken to the Lord’s words as you study the rest of Doctrine and Covenants 45 in the next lesson?

 **5.** Write the following at the bottom of today’s assignments in your scripture study journal:

*I have studied Doctrine and Covenants 45:1–15 and completed this lesson on (date).*

*Additional questions, thoughts, and insights I would like to share with my teacher:*

## UNIT 11: DAY 2

# Doctrine and Covenants 45:16–75

### Introduction

Throughout history, many people have had differing opinions about the Second Coming of Jesus Christ. This was true in March 1831 when the revelation in Doctrine and Covenants 45 was received. In this revelation the Lord gave details about certain events and signs associated with His Second Coming, including the establishment of the New Jerusalem (or Zion). The Lord also directed the Prophet Joseph Smith to begin working on a translation of the New Testament, to prepare the Saints for things to come.

## Doctrine and Covenants 45:16–46

*The Savior reveals many signs and events that are to precede His Second Coming*

How do you know when a storm is approaching? Why is it helpful to know what those signs are?

Those who know the signs of an approaching event can be prepared for it. What signs are you aware of to alert you that the following events are here or are coming?

- The last days
- The Second Coming of Jesus Christ

As shown in Doctrine and Covenants 45:16, people during Jesus Christ’s mortal ministry, like those during the time of Joseph Smith and today, were interested in knowing more about the events leading up to the Savior’s Second Coming. In Doctrine and Covenants 45 the Lord described signs to alert us of this approaching event. Many of the passages in Doctrine and Covenants 45 are what the Lord revealed to His disciples who lived with Him in His mortal ministry (see Matthew 24).

 **1.** To identify signs that the Savior said would precede His Second Coming, write the following references in your scripture study journal; write each reference on a separate line and leave some space to write down the signs: D&C 45:18–21; D&C 45:22–27; D&C 45:28–31, 33; D&C 45:40–43. Then read the verses in each reference, looking for signs that precede the Second Coming, and record the signs next to the reference. If you choose to do so, draw pictures of what you read instead of writing the signs.

Some of these signs of the Second Coming have already occurred. For example, the temple in Jerusalem was destroyed by the Romans in A.D. 70 (see D&C 45:18–21). The phrase “the times of the Gentiles” in Doctrine and Covenants 45:25 refers to the time when the gospel is offered primarily to the Gentiles, or those of non-Jewish descent, which is the time that we live in today.

Read Doctrine and Covenants 45:34, looking for how the disciples during the Savior’s mortal ministry felt when He told them these things. Why do you think people today might feel similar feelings regarding the signs of the Savior’s Second Coming?

Read Doctrine and Covenants 45:38, looking for what we will know when we see the signs coming to pass.

Read Doctrine and Covenants 45:32, 39. As you study these verses, identify what the followers of Jesus Christ in our day will do to be ready for His Second Coming. Look at verse 39, footnote *a* to learn of another word for “feareth.”

Based upon what you have studied, what is the Lord’s promise to those who stand in holy places and reverence Him? Complete this principle: **If we stand in holy places and watch for the signs, we will \_\_\_\_**

Often we think of “holy places” as Church sites, like the temples or meetinghouses. As you read the following statement, look for another way we stand in holy places:

“‘Holy places’ may have more to do with *how* one lives than *where* one lives. If we live worthy of the constant companionship of the Holy Ghost, then we stand in a holy place. . . .

“A holy place is any place where a person enjoys the Spirit of God” (*Doctrine and Covenants Student Manual*, 2nd ed. [Church Educational System manual, 2001], 196).

 **2.** Answer the following questions in your scripture study journal:

- a. How can we live in the world today and yet still stand in holy places?
- b. How does a follower of Jesus Christ fear, or revere, Him on a daily basis? Describe a person you know who does this.

## Doctrine and Covenants 45:47–59

*The Savior reveals signs and wonders that will attend His appearance to the Jews*

When Jesus Christ returns He will make some appearances to specific groups. He will then appear in great power, majesty, and glory, in such a manner that all the world will see Him. During one of His appearances, He will stand on the Mount of Olives in Jerusalem as the Jews are being attacked. Read Doctrine and Covenants 45:48, looking for what will happen to this mount and the earth when the Savior stands upon it.



Complete the following chart by reading the verses and answering the questions in your own words:

D&C 45:49–50: What will happen to the nations of the earth at the Second Coming?	D&C 45:51–53: Why will the Jews weep when the Lord returns?

If you are not familiar with the parable of the ten virgins, read Matthew 25:1–13. In what ways were five of the virgins wise? Read Doctrine and Covenants 45:56–57, looking for how to be wise in your preparation for Second Coming. Consider marking what you find.



Write an “If-Then” principle explaining what we must do to be wise and prepare for the Second Coming:

---



---



---

Elder Dallin H. Oaks of the Quorum of the Twelve Apostles spoke about this parable and what the ten virgins represent: “The arithmetic of this parable is chilling. The ten virgins obviously represent members of Christ’s Church, for all were invited to the wedding feast and all knew what was required to be admitted when the bridegroom came. But only half were ready when he came” (“Preparation for the Second Coming,” *Ensign or Liahona*, May 2004, 8).



President Spencer W. Kimball used the parable of the ten virgins to teach about how we can be ready for the Savior’s Second Coming:

“I believe that the Ten Virgins represent the people of the Church of Jesus Christ and not the rank and file of the world. All of the virgins, wise and foolish, had accepted the invitation to the wedding supper; they had knowledge of the program and had been warned of the important day to come. . . .

“At midnight! Precisely at the darkest hour, when least expected, the bridegroom came. When the world is full of tribulation and help is needed, but it seems the time must be past and hope is vain, then Christ will come. The midnights of life are the times when heaven comes to offer its joy for man’s weariness. But when the cry sounds, there is no time for preparation. . . .

“The foolish asked the others to share their oil, but spiritual preparedness cannot be shared in an instant. The wise had to go, else the bridegroom would have gone unwelcomed. They needed all their oil for themselves; they could not save the foolish. The responsibility was each for himself.

“This was not selfishness or unkindness. The kind of oil that is needed to illuminate the way and light up the darkness is not shareable. How can one share obedience to the principle of tithing; a mind at peace from righteous living; an accumulation of knowledge? How can one share faith or testimony? How can one share attitudes or chastity, or the experience of a mission? How can one share temple privileges? Each must obtain that kind of oil for himself.

“The foolish virgins were not averse to buying oil. They knew they should have oil. They merely procrastinated, not knowing when the bridegroom would come.

“In the parable, oil can be purchased at the market. In our lives the oil of preparedness is accumulated drop by drop in righteous living. Attendance at sacrament meetings adds oil to our lamps, drop by drop over the years. Fasting, family prayer, home teaching, control of bodily appetites, preaching the gospel, studying the scriptures—each act of dedication and obedience is a drop added to our store. Deeds of kindness, payment of offerings and tithes, chaste thoughts and actions, marriage in the covenant for eternity—these, too, contribute importantly to the oil with which we can at midnight refuel our exhausted lamps” (*Faith Precedes the Miracle* [1972], 253–56).



**3.** Answer the following question in your scripture study journal: How are you preparing for the Second Coming of Jesus Christ by receiving the truth and taking the Holy Spirit as your guide?



President Boyd K. Packer, President of the Quorum of the Twelve Apostles, testified of the importance of having the Spirit in troubled times:

“We live in troubled times—very troubled times. We hope, we pray, for better days. But that is not to be. The prophecies tell us that. We will not as a people, as families, or as individuals be exempt from the trials to come. . . .

“We need not live in fear of the future. We have every reason to rejoice and little reason to fear. If we follow the promptings of the Spirit, we will be safe, whatever the future holds. We will be shown what to do” (“The Cloven Tongues of Fire,” *Ensign*, May 2000, 8).

### Doctrine and Covenants 45:60–61

*The Lord directs the Prophet Joseph Smith to begin his translation of the New Testament*

Read or quote the eighth article of faith. What does the phrase “as far as it is translated correctly” suggest about the Bible? Joseph Smith turned to passages in the Bible when he sought to know about which church to join. He loved the Bible and found great consolation from its words. However, as he studied it, he noticed errors and contradictions and felt that some information was missing or incomplete, and he explained, “It was apparent that many important points touching the salvation of man had been taken from the Bible, or

lost before it was compiled” (*Teachings of Presidents of the Church: Joseph Smith* [2007], 217; see also Bible Dictionary, “Bible”).

He also said: “I believe the Bible as it read when it came from the pen of the original writers. Ignorant translators, careless transcribers, or designing and corrupt priests have committed many errors” (*Teachings: Joseph Smith*, 207; see also 1 Nephi 13:25–29).

Around the fall of 1830, the Lord commanded the Prophet Joseph Smith to translate the Bible. This “translation” was not from one language to another, nor did the Prophet have an original biblical manuscript to work from. Instead, he would read and study passages from the King James version of the Bible and make corrections and additions as inspired by the Spirit. With its inspired revisions, the Joseph Smith Translation (JST) has blessed the world by clarifying doctrinal content in the Bible, especially concerning the mission of Jesus Christ and the nature of God.

When the revelation in Doctrine and Covenants 45 was given on March 7, 1831, Joseph Smith was working on his inspired revision of the Old Testament. The day after Joseph received this revelation, he starting translating the New Testament. Read Doctrine and Covenants 45:60–61 to discover why.

### Doctrine and Covenants 45:62–64

*The Saints are forewarned to gather into western countries*

The Lord directed the early Saints to move westward, “out from the eastern lands” (D&C 45:64). Look at the following map to visualize this area.



Read Doctrine and Covenants 45:62–64 to identify a reason why the Lord commanded His Saints to gather toward “the western countries” (D&C 45:64).

What did the Lord say was “even at your doors” (D&C 45:63)? \_\_\_\_\_

Ponder what you think the imagery of “even at your doors” means.

In 1831 the western border of the United States extended to the western edge of Missouri. The Lord would later guide the Saints even farther west—to a place now known as Utah. As the Saints obeyed the Lord’s counsel, they were guided away from the calamities connected with the Civil War in America (1861–65).

## Doctrine and Covenants 45:65–75

*The Lord describes the New Jerusalem (Zion)*

If you could live anywhere, where would you want to live? Why?

Read Doctrine and Covenants 45:65–67, looking for the name of the Saints’ land of inheritance and reasons why it would be a desirable place for them to live.



4. In your scripture study journal, list the reasons why the New Jerusalem would be a place you would like to live.

These verses teach that **the New Jerusalem will be a place of peace and safety, and the glory of the Lord will be there.** In Doctrine and Covenants 45:67, notice what will be there in addition to the glory of the Lord. What did the Lord say was a result of having “the terror of the Lord” also present there?

Read Doctrine and Covenants 45:68–71, looking for who will gather to the New Jerusalem (Zion).



5. In your scripture study journal, finish this statement: *Because of what I have learned today, I will prepare for things to come by . . .*



6. Write the following at the bottom of today’s assignments in your scripture study journal:

*I have studied Doctrine and Covenants 45:16–75 and completed this lesson on (date).*

*Additional questions, thoughts, and insights I would like to share with my teacher:*

## UNIT 11: DAY 3

# Doctrine and Covenants 46

## Introduction

The revelation in Doctrine and Covenants 46 was received on March 8, 1831—nearly one year after the Church was organized. In this revelation the Lord reminded the Saints that Church meetings are to be conducted by the Spirit, and He emphasized that people who are not members of the Church are not to be cast out of public meetings. The Lord also explained the purposes of the gifts of the Spirit.

## Doctrine and Covenants 46:1–6

*The Lord instructs the Saints concerning their Church meetings*

Imagine you were asked to plan an entire sacrament meeting. How would you choose the music, who would pray, the topics of the talks, who would give the talks, and in what order the talks would be given?

Read Doctrine and Covenants 46:1–2, looking for the instruction the Lord gave about how meetings are to be conducted. The word *conduct* in verse 2 includes both planning and directing Church meetings.



1. In your scripture study journal, describe what you think a meeting is like when it is “directed and guided by the Holy Spirit.”



2. Answer the following questions in your scripture study journal:

- What might Church leaders and members need to do in order for a Church meeting to be directed and guided by the Holy Ghost?
- What can you do to contribute to the influence of the Spirit in Church meetings?

Mark the words or phrases in Doctrine and Covenants 46:2 that teach the following principle: **Church leaders are to be guided by the Holy Spirit as they conduct meetings.**

Think about some of the places where you have seen the phrase “Visitors Welcome” posted. Read the section introduction to Doctrine and Covenants 46, looking for who the early Saints admitted into their meetings. Then read Doctrine and Covenants 46:3–6 to find phrases and words that show **the Lord has commanded us to welcome all people to our public meetings**. You may already know that the phrase “Visitors Welcome” is posted on our Church meetinghouses.

Ponder the following situation: A young woman visits a new ward with her family for the first time. After sacrament meeting, a ward member greets the family and shows them where to go for Sunday School. He takes the young woman to her class and introduces her to the teacher. The young men and young women in the class briefly acknowledge the young woman and then proceed to visit amongst themselves, ignoring her.

How could this situation be different if the members of the Sunday School class understood the commandment to welcome all to our public meetings?

 **3.** In your scripture study journal, list a few ways in which you can help those who are not members of the Church, members who have not been to church for a while, new members of your ward or branch, and visitors feel welcome.

Some of the ways you listed may be difficult for you to do, but think of times when you attended a meeting or activity in a different ward or branch of the Church. What did other Church members do or what would you have liked them to do to help you feel welcome? Think and pray about how you can help others feel more welcome at Church meetings and activities.

## Doctrine and Covenants 46:7–33

### *The Lord explains the purpose of gifts of the Spirit*

What does it mean to be deceived? Can you think of a time when you felt you were deceived? What can we do to avoid being deceived?

When the Prophet Joseph Smith arrived in Ohio, he witnessed strange and fanatical behavior in some Church members; for example, some claimed to be under the influence of the Spirit but were manifesting behaviors not consistent with the Holy Ghost. Leaders and other members were suspicious that the behaviors

were brought on by an evil influence. Study Doctrine and Covenants 46:7–8, looking for what the Lord counseled His people to do so they would not be deceived by false spirits or false doctrines.

 **4.** Answer the following questions in your scripture study journal:

- a. According to Doctrine and Covenants 46:7–8, what helps us avoid being deceived?
- b. Why do you think that could help a person not be deceived?

Doctrine and Covenants 46:7 teaches the following principle: **When we follow the directions of the Spirit in all holiness and do all things with prayer and thanksgiving, we can avoid being deceived.**

You may want to mark in Doctrine and Covenants 46:8 what the Lord said we should earnestly seek.

Read Doctrine and Covenants 46:9–12, 26, looking for what the Lord wants us to understand about the gifts of the Spirit. (You may want to mark what you find.) Based on what you learned from these verses, complete the following principle: **If we earnestly seek the best gifts,** \_\_\_\_\_

 **5.** In your scripture study journal, write why you think it is important that we seek spiritual gifts for the benefit of the children of God rather than for selfish purposes. Then answer the following question: According to Doctrine and Covenants 46:11–12, why are the spiritual gifts of each person important to the Church? (see also 1 Corinthians 12).

Though our gifts might vary, the Lord’s Church needs them all. Everyone has a role and responsibility in the building of the kingdom of God on the earth. Study the list of spiritual gifts the Lord gave in Doctrine and Covenants 46:13–27. You may want to mark each of them.

To help you understand some of these gifts of the Spirit better, match the gift listed in the following chart with the explanation that best fits it. (Answers can be found at the end of the lesson.)



Gift	Explanation
___ 1. The gift “to know the differences of administration” (D&C 46:13)	a. This gift is commonly manifest in missionaries who are able to learn and understand languages quickly.
___ 2. The gift “to know the diversities of operations” (D&C 46:16)	b. This gift allows a person to recognize or understand true intentions and hidden motivations. It helps a person to detect hidden evils and to see the good in others.
___ 3. The gift of “the discerning of spirits” (D&C 46:23)	c. This gift is often manifest in leaders who recognize how others’ gifts, though different from each other, can be helpful in various positions of service.
___ 4. The gift “to speak with tongues” and “the interpretation of tongues” (D&C 46:24–25)	d. This gift is manifest in a person’s ability to see the differences between authentic gifts or workings of the Spirit and false spirits, doctrines, or commandments.

The list of the gifts of the Spirit identified in Doctrine and Covenants 46 are only a few of the gifts that are available. Elder Bruce R. McConkie of the Quorum of the Twelve Apostles explained: “Spiritual gifts are endless in number and infinite in variety. Those listed in the revealed word are simply illustrations of the boundless outpouring of divine grace that a gracious God gives those who love and serve him” (*A New Witness for the Articles of Faith* [1985], 371).

Can you think of spiritual gifts you have seen or can identify that are not mentioned in Doctrine and Covenants 46?

If you have received your patriarchal blessing, the Lord may have listed some of the gifts He has given you. You may also experience spiritual gifts as you serve Heavenly Father and His children in various Church callings. Doctrine and Covenants 46 teaches that those called to “watch over the Church” are given the gift to judge which spiritual gifts are of God (see D&C 46:27).

You can have faith in your bishop’s ability to discern your gifts and where you might be able to best serve and bless others in the Church, even when those gifts might not yet be known to you.



It may be helpful to understand more about the gift of tongues. The Prophet Joseph Smith taught the following about this gift of the Spirit:

“[The gift of tongues was] given for the purpose of preaching among those whose language is not understood; as on the day of Pentecost, etc., and it is not necessary for tongues to be taught to the Church particularly, for any man that has the Holy Ghost, can speak of the things of God in his own tongue as well as to speak in another; for faith comes not by signs, but by hearing the word of God” (*Teachings of Presidents of the Church: Joseph Smith* [2007], 383–84).

“If anything is taught by the gift of tongues, it is not to be received for doctrine” (*Teachings: Joseph Smith*, 384).

“Speak not in the gift of tongues without understanding it, or without interpretation. The devil can speak in tongues; the adversary will come with his work; he can tempt all classes; can speak in English or Dutch. Let no one speak in tongues unless he interpret, except by the consent of the one who is placed to preside; then he may discern or interpret, or another may” (*Teachings: Joseph Smith*, 384).

Elder Bruce R. McConkie of the Quorum of the Twelve Apostles explained: “Tongues and their interpretation are given for special purposes under special circumstances. There are a host of gifts that are far more important and in the use of which there is less chance for deception. The gifts of exhortation, of preaching, of expounding doctrine, of teaching the gospel—though not nearly so dramatic—are far greater and of more value than tongues” (*Mormon Doctrine*, 2nd ed. [1966], 800).

Ponder for a moment about how the gifts of the Spirit have benefited you. Also think about how you can seek for and use your gifts to bless the children of God.

The Lord concluded this revelation by instructing His followers on what they must do. Read Doctrine and Covenants 46:31–33, looking for what He taught.

## Scripture Mastery—Doctrine and Covenants 46:33

Spend a few minutes memorizing Doctrine and Covenants 46:33. If possible, recite it to a family member or friend.

 **6.** In your scripture study journal, list a number of ways you can “practice virtue and holiness.” As you write your list, choose two or three sections from the *For the Strength of Youth* booklet and use them to help you add to your list. Write a goal about how you plan to practice virtue and holiness before the Lord.

 **7.** Write the following at the bottom of today’s assignments in your scripture study journal:

*I have studied Doctrine and Covenants 46 and completed this lesson on (date).*

*Additional questions, thoughts, and insights I would like to share with my teacher:*

Answers to the matching assignment: 1) c, 2) d, 3) b, 4) a.

### UNIT 11: DAY 4

# Doctrine and Covenants 47–48

## Introduction

In March 1831, the Prophet Joseph Smith received the revelations recorded in Doctrine and Covenants 47 and 48. In Doctrine and Covenants 47, the Lord appointed John Whitmer to replace Oliver Cowdery as Church historian and recorder. In Doctrine and Covenants 48, the Lord instructed the Saints in Ohio to help those Church members coming from New York. The Lord also directed Church members to prepare to purchase land for the building of the city of Zion in Missouri.

## Doctrine and Covenants 47

*The Lord appoints John Whitmer to keep a recorded history of the Church*

Think of a past event with spiritual significance that you participated in and feel is worth remembering (for example: a temple dedication, a Church meeting, or a family activity like a wedding or funeral).

If possible, tell a family member about this event and share your answers to the following questions. (If a family member is not available, simply ponder these questions.)

- What impressed you most about this event?
- What value is there in remembering this event?
- How could knowledge of this event bless your posterity 100 years from now?

Read the section introduction to Doctrine and Covenants 47 and verses 1–3 of this section to discover what the Lord called John Whitmer to do. Why do you think it is important for someone to write the history of the Church?



John Whitmer copied revelations Joseph Smith had previously received into a book now known as Revelation Book I. This book contains many of the earliest transcripts of these revelations.

Think of an event from Church history that is inspiring to you. How did you learn about that event?

We know about past events in Church history because someone made and kept records of them to be preserved for our day and future generations. Recall that in a previous revelation the Lord said, “There shall be a record kept among you” (D&C 21:1). There is a historian and recorder today in the Church who is appointed by the First Presidency. However, the historian cannot observe and record everything happening in the Church, so he is instructed to collect histories from others. In a general sense, the experiences of Church members are part of the history of the Church and can influence future generations.

Elder Marlin K. Jensen of the Seventy, who served as Church historian and recorder from 2005–12, taught, “Many of the Church’s greatest stories are contained in personal and family histories, and these are a part

of our individual and family heritages" ("There Shall Be a Record Kept among You," *Ensign* or *Liahona*, Dec. 2007, 31).

 **1.** Answer the following question in your scripture study journal: Why does your personal history matter?

 **2.** Think about spiritually significant events in your life that you feel are worth remembering. Imagine that your children and grandchildren are going to read your personal account of one of these events. In your scripture study journal, tell what the event was and answer the following questions:

- a.** What part of the event would you write about?
- b.** What would you want your descendants to feel and know about the event?

Read Doctrine and Covenants 47:4 to learn what the Lord promised John Whitmer would be given in his efforts "to keep the church record and history continually" (D&C 47:3).

Based on what you read in Doctrine and Covenants 47:4, complete the following principle: **If we \_\_\_\_\_, the Spirit can help us \_\_\_\_\_.**

The Holy Ghost can bring things to our remembrance (see John 14:26) and help us write about events and situations in ways that will bless family members and others in future generations. Pray for and live worthy of the help of the Spirit as you make an effort to keep a personal history.

Ponder other ways you can improve in your efforts to keep a personal journal or write a personal history of significant events, ordinances, and people in your life.

## Doctrine and Covenants 48

*The Saints in Ohio are to assist those coming from New York and prepare for their inheritance in Zion*

Imagine that Church members in a distant area were recently affected by a natural disaster and had to be evacuated from their homes. Church leaders have asked you and your family to house some of the displaced people for several months. What questions and concerns would you and your family have? What concerns and feelings do you think those moving into your home would have?

Look at Church history map 3 in your scriptures: "The New York, Pennsylvania, and Ohio Area of the USA." Locate Palmyra, New York, and Kirtland, Ohio. Approximately how many miles or kilometers separate these cities? \_\_\_\_\_

In February 1831, the Prophet Joseph Smith moved from Palmyra, New York, to Kirtland, Ohio. Many Church members followed during the next few months. These members had left many earthly goods and resources to follow God's command and come to Ohio, and they were in need of assistance. What do you think the Lord might require of you if you were living in Ohio and witnessed some of these Saints moving into your area with no home and very little means to live?

Read Doctrine and Covenants 48:1–3 to discover what the Lord told Church members in Ohio to do for Church members moving into the region. One principle we learn from these verses is that **the Lord commands Latter-day Saints to share what they have with those in need.** You may wish to write this principle next to verse 2.

Notice in Doctrine and Covenants 48:3 that the Lord expected those with resources and means who were moving to Ohio to purchase land there. Likewise, the Lord expects us to use our resources when we have them and not rely on others to provide for us.

 **3.** Answer the following question in your scripture study journal: What are some ways we can share what we have with others in the Church today?

Consider how a young man fulfilled the commandment to impart to those in need as you read the following account told by President James E. Faust of the First Presidency:



"Some years ago a priests quorum decided to gather food for the needy as a service project. Jim, one of the priests, was excited to participate and was determined to collect more food than anyone else. The time arrived when the priests met at the chapel. They all went out at the same time and returned at a specified time later in the evening. To everyone's

### Visualizing

Look for descriptive details that can help you create a mental picture as you read. Imagine being present at certain events. Visualizing can help strengthen your testimony of the reality of what you read in the scriptures. Try this skill with Doctrine and Covenants 48. For example, imagine how difficult it would have been to travel the distance from Palmyra, New York, to Kirtland, Ohio, during the winter of 1831. How would you feel about moving to a strange city where you did not have a place to live?

surprise, Jim's cart was empty. He seemed rather [quiet], and some of the boys made fun of him. Seeing this and knowing that Jim had an interest in cars, the adviser said, 'Come outside, Jim. I want you to look at my car. It's giving me some trouble.'

"When they got outside, the adviser asked Jim if he was upset. Jim said, 'No, not really. But when I went out to collect the food, I really got a lot. My cart was full. As I was returning to the chapel, I stopped at the home of a nonmember woman who is divorced and lives within our ward boundaries. I knocked on the door and explained what we were doing, and she invited me in. She began to look for something to give me. She opened the refrigerator, and I could see there was hardly anything in it. The cupboards were bare. Finally, she found a small can of peaches.

"I could hardly believe it. There were all these little kids running around that needed to be fed, and she handed me this can of peaches. I took it and put it in my cart and went on up the street. I got about halfway up the block when I just felt warm all over and knew I needed to go back to that house. I gave her all the food.'

"The adviser said, 'Jim, don't you ever forget the way you feel tonight, because that's what it is all about'" ("Spiritual Nutrients," *Ensign* or *Liahona*, Oct. 2006, 54).

 **4.** Answer the following questions in your scripture study journal:

- a. What do you think was happening to Jim when he felt that he should go back?
- b. When the adviser said that the way Jim felt was "what it is all about," what do you think he meant?

 **5.** Identify one way you can help meet the needs of someone else, perhaps by sharing what you have. For example, you could help a family member, a friend, someone in one of your Church classes or quorum, or someone in your neighborhood or school. In your scripture study journal, write down what you will do to help the person you thought of, and then follow through with your plan.

In Doctrine and Covenants 48:4–6 the Lord explained that He wanted the Saints to prepare to purchase land when He would reveal the location of the city of Zion, or New Jerusalem. The Lord asked them to save all of the money they could in preparation for laying the foundation of this city.

 **6.** Write the following at the bottom of today's assignments in your scripture study journal:

*I have studied Doctrine and Covenants 47–48 and completed this lesson on (date).*

*Additional questions, thoughts, and insights I would like to share with my teacher:*

## UNIT 12: DAY 1

# Doctrine and Covenants 49

## Introduction

Leman Copley, who was a recent convert to the Church, wanted missionaries to preach the gospel to members of his former religious group, the Shakers. However, he continued to hold on to some of the false beliefs of that religion. Concerned about Leman's lingering beliefs, the Prophet Joseph Smith inquired of the Lord, and on May 7, 1831, he received the revelation that is now recorded in Doctrine and Covenants 49. In this revelation the Lord commanded Sidney Rigdon and Parley P. Pratt to accompany Leman to preach the gospel to the Shaker community. The Lord also clarified doctrines that the Shakers misunderstood, including the nature of the Second Coming of Christ, the need for baptism, the importance of marriage and family, and the use of animals for food.

## Doctrine and Covenants 49:1–4

*The Lord calls Sidney Rigdon, Parley P. Pratt, and Leman Copley to preach to the Shakers*

Have you ever seen a monkey trap? One way to catch a monkey is to place an object, such as a nut or a piece of food, in a container with a hole just large enough for a monkey to put its hand in. The container is secured by a rope or cable so the monkey cannot run away with the trap. When the monkey reaches in and grasps the object, it is unable to remove its hand because its fist is bigger than the hole. In their determination to hold on to the object, some monkeys will allow themselves to be caught.





Read the section introduction to Doctrine and Covenants 49, looking for ways the situation described is like a monkey trap. What were some of the false beliefs that Leman Copley would not give up?



**1. Write *Shakers' Beliefs* in your scripture study journal.**

Then list the four beliefs of the Shakers that are mentioned in the section introduction. You also might want to mark them in your scriptures.

Members of the United Society of Believers in Christ's Second Appearing were commonly called Shakers because of their manner of worship, which involved shaking their bodies as they sang, danced, and clapped their hands to music.

Read Doctrine and Covenants 49:1–4, looking for what the Lord revealed about the Shakers' beliefs. In verse 2, you may want to mark what the Lord said the Shakers desired.



**2. Answer the following questions in your scripture study journal:**

- What do you think it means to "desire to know the truth in part, but not all" (D&C 49:2)?
- What is an example of how a member of the Church might accept some truths or standards of the gospel but ignore others?

What word would you put in the blank to complete the following principle taught in Doctrine and Covenants 49:2? **Being right before the Lord includes desiring to receive \_\_\_\_\_ of the truth He has revealed.**

You might want to write this principle in your scriptures next to verse 2. Ponder the blessings a person might miss by choosing to accept only part of the truth.

You may be able to think of some traps that members of the Church get caught in. Some members might accept some teachings or standards but not all of them, while other members might hold on to attitudes that keep them from being "right before [the Lord]" (D&C 49:2). For example, a person might go to church on Sunday but then use the rest of the day for activities that break the Sabbath. Another person might read the scriptures and pray for the Spirit and then listen to music that drives the Holy Ghost away.



Elder Joseph B. Wirthlin of the Quorum of the Twelve Apostles taught:

"Satan is the master of deception and the father of all lies. Only by exercising faith in the Savior and his atoning sacrifice and

keeping all the commandments are you protected from Satan's incessant, insidious efforts to lead you carefully into his power.

"You cannot approach the gospel as you would a buffet or smorgasbord, choosing here a little and there a little. You must sit down to the whole feast and live the Lord's loving commandments in their fullness.

"You have been taught the commandments. You know what to do: pray, study the scriptures, fast, pay your tithes and offerings, attend your meetings, partake of the sacrament, magnify your callings and serve others, sustain your Church leaders, make and keep sacred covenants, share the gospel, be honest, true, chaste, benevolent, and virtuous" ("It's Your Choice," *New Era*, Feb. 1998, 4).



**3. In your scripture study journal, explain the danger of accepting some commandments or standards while holding on to false beliefs or practices. How is this a spiritual "trap"?**

Consider what you might need to let go of in order to receive all of the blessings Heavenly Father intends for you. You may want to write a goal to let go of something that is keeping you from being right before the Lord.

## Doctrine and Covenants 49:5–28

*The Lord corrects some false doctrines of the Shakers and commands His servants to invite them to repent and be baptized*

The Lord commanded Leman Copley, Sidney Rigdon, and Parley P. Pratt to preach the gospel to the Shakers (see D&C 49:1–4). Leman Copley had been hoping that some of the elders would preach to the members of his former church.

Can you imagine telling a group of people that some of their beliefs are false and then teaching them the correct gospel principles? When Parley P. Pratt, Sidney Rigdon, and Leman Copley visited the Shakers, they took a copy of the revelation in Doctrine and Covenants 49 and read it to them.

Study each scripture passage in the left column of the following chart, and then match it with the principle it teaches in the right column. Then consider the accompanying questions.

___ 1. D&C 49:5–8	a. <b>No one knows when the Second Coming will occur.</b>
___ 2. D&C 49:11–14	b. <b>If we know the signs of the Second Coming, we will not be deceived by false claims.</b> Why is it important for us to be aware of the signs of the Lord's Second Coming?
___ 3. D&C 49:15–17	c. <b>Jesus Christ has commanded His servants to call upon people to believe in Him, repent, be baptized, and receive the gift of the Holy Ghost.</b> Why are you grateful that you have been baptized and that you have received the gift of the Holy Ghost? Why do you look forward to helping other people receive these ordinances?
___ 4. D&C 49:18–21	d. <b>The Lord has provided the animals of the earth for our use.</b> Why do you think the Lord is not pleased with those who kill animals needlessly?
___ 5. D&C 49:22–25	e. <b>Marriage between a man and a woman is ordained of God, and husbands and wives are commanded to be one and to have children.</b> (The phrase "that the earth might answer the end of its creation; . . . that it might be filled with the measure of man" indicates one of the purposes of the earth's creation.) What purposes does marriage between a man and a woman fulfill in Heavenly Father's plan?

The First Presidency and the Quorum of the Twelve Apostles have taught: "The first commandment that God gave to Adam and Eve pertained to their potential for parenthood as husband and wife. We declare that God's commandment for His children to multiply and replenish the earth remains in force. We further declare that God has commanded that the sacred powers of procreation are to be employed only between man and woman, lawfully wedded as husband and wife" ("The Family: A Proclamation to the World," *Ensign*, Nov. 2010, 129).



4. Answer the following questions in your scripture study journal:

- a. Why do you think Satan attempts to destroy marriages? Why does he try to convince people that they should not marry?
- b. Why is marriage between a man and a woman important to the Lord's plan? How does same-gender marriage frustrate the Lord's plan?
- c. What can you do now to prepare for celestial marriage?

Think about the monkey trap. Ponder the principle that we need to accept all of the Lord's teachings in order to be right before Him. Then read the Lord's counsel and promises in Doctrine and Covenants 49:26–28. As you read these verses, imagine that the Lord is speaking directly to you about your efforts to be right before Him. Consider how His counsel and promises apply to you.



5. Write the following at the bottom of today's assignments in your scripture study journal:

*I have studied Doctrine and Covenants 49 and completed this lesson on (date).*

*Additional questions, thoughts, and insights I would like to share with my teacher:*

Answers to the matching assignment: 1) a, 2) c, 3) e, 4) d, 5) b.

# Doctrine and Covenants 50

## Introduction

When the Prophet Joseph Smith arrived in Kirtland, Ohio, he observed that “some strange notions and false spirits had crept in among” some of the Saints. He began teaching with “caution and . . . wisdom” to overcome these things (see *History of the Church*, 1:146). Elder Parley P. Pratt returned from a mission and observed similar behavior in branches of the Church outside of Kirtland. He and other elders went to Joseph to receive guidance (see *History of the Church*, 1:170). In May 1831, the Prophet inquired of the Lord and received the revelation recorded in Doctrine and Covenants 50. In this revelation the Lord instructed the Saints to teach and receive the gospel by the Spirit of truth.

## Doctrine and Covenants 50:1–9

*The Lord warns elders of the Church about false spirits*

Do you know what it means to edify someone? It means to build someone up—especially to strengthen someone spiritually or emotionally or to instruct and enlighten someone. Can you think of a time when you felt edified as someone taught you gospel principles? When have you felt that you helped edify others?

Recall the introduction to this lesson. New members of the Church in the Kirtland area had introduced strange, loud, and confusing activities into their worship services. These activities stirred people’s emotions, but they were not edifying.

The Prophet Joseph Smith wrote about some of the effects of following false spirits: “Soon after the Gospel was established in Kirtland, and during the absence of the authorities of the Church, many false spirits were introduced, many strange visions were seen, and wild, enthusiastic notions were entertained; men ran out of doors under the influence of this spirit, and some of them got upon the stumps of trees and shouted, and all kinds of extravagances were entered into by them; one man pursued a ball that he said he saw flying in the air, until he came to a precipice, when he jumped into the top of a tree, which saved his life; and many ridiculous things were entered into, calculated to bring disgrace upon the Church of God, to cause the Spirit of God to be withdrawn, and to uproot and destroy

those glorious principles which had been developed for the salvation of the human family” (in *History of the Church*, 4:580).

Some of the elders of the Church did not understand what was happening, so they asked Joseph Smith for counsel. He inquired of the Lord and received a revelation that would help the Saints edify one another as they taught and learned gospel truths.

Read Doctrine and Covenants 50:1–3, looking for the influence that was leading the Saints to act in ways that were not edifying. According to verse 3, why did Satan want to deceive the Saints?

Read Doctrine and Covenants 50:4–9, looking for the Lord’s warning about some people among the Church members in Ohio. A hypocrite is a person whose actions do not match his or her stated beliefs or who pretends to be virtuous but is not (see Matthew 6:2, footnote 2a). In Doctrine and Covenants 50:6, 8, mark what the Lord said would happen to them.

## Doctrine and Covenants 50:10–36

*The Lord declares that we must teach and learn by the Spirit*



1. Answer the following questions in your scripture study journal:

- What is required to be an effective teacher of the gospel?
- What is required to be an effective learner of the gospel?

Read Doctrine and Covenants 50:13–20, looking for answers to these questions. Consider marking what you find in your scriptures and adding it to the list in your scripture study journal. Notice how much the Lord emphasized the need for the Holy Spirit in teaching and learning the gospel.



2. Answer the following questions in your scripture study journal:

- What roles of the Holy Ghost are mentioned in Doctrine and Covenants 50:14?
- What do you think it means to teach the gospel “by the Spirit” (D&C 50:14)? What do you think it means to teach it by “some other way” (D&C 50:17)?
- What do you think it means to “receive [the word of truth] by the Spirit of truth” (D&C 50:19)? What do you think it means to receive it by “some other way” (D&C 50:19)?

Look through the scripture references listed in the Topical Guide for “Holy Ghost, Mission of.” Identify passages that help you understand what it means to teach and receive (be taught) truth by the Spirit of truth.

Circle any of the following settings in which you have had an opportunity to teach or testify of the gospel:

Family home evening	With friends	Seminary
Church meeting	Home teaching	

When you have an opportunity to teach the gospel, how does your understanding of the Holy Ghost affect the way you prepare and teach?

Circle any of the following settings in which you have been a student:

Family home evening	With friends	Seminary
Church meeting	Home teaching visit	In conversations at home

 **3.** Choose one of the settings you circled in the preceding lists in which you either taught or were taught by the Spirit. Write about this experience in your scripture study journal, and consider sharing what you learned with a family member or friend.

Ponder what you can do to improve your efforts to learn by the Spirit in these settings.



Elder Jack H. Goaslind of the Seventy shared the experience of a young man who discovered that his actions and attitude affected his ability to learn by the Spirit:

“How many of you have assumed the ‘bored position’ during sacrament meeting? You know the position: bent forward at the waist, chin resting on hands, elbows on knees, staring vacantly at the floor. Has it occurred to you that it is your *choice* whether the meeting is interesting or not? . . .

“President Spencer W. Kimball said that worship ‘is an individual responsibility, and regardless of what is said from the pulpit, if one wishes to worship the Lord in spirit and in truth, he may do so. . . . If the service is a failure to you, you have failed. No one can worship for you; you must do your own waiting upon the Lord.’ (*Ensign*, Jan. 1978, p. 5.)

“One youth described how he first experienced the spirit of worship. He had been marginally active

through his Aaronic Priesthood years. When he attended sacrament meeting, he usually sat in the back with a group of his friends, and he was less than a model of reverence. One day, however, he came in a little late, and there were no seats by his friends. He sat alone, and for the first time in his life, he closed his eyes during the prayers, he sang the hymns, he listened to the sacrament prayers, and he paid attention to the speakers. About midway through the first speaker, he found tears welling up in his eyes. With some embarrassment, he carefully glanced around; no one else seemed emotional. He didn’t know for sure what was happening to him, but the experience changed his life. It was during that meeting that he really started his spiritual preparation for his mission. He *felt* something, and fortunately, he acted and thus sustained those feelings” (“Yagottawanna,” *Ensign*, May 1991, 46).

### Pondering

Pondering includes thinking, meditating, asking questions, and evaluating what you know and what you are trying to understand. Pondering often helps us understand what we need to do to apply gospel principles. As you study Doctrine and Covenants 50, consider taking time to ponder passages that you want to understand more deeply.

 **4.** In your scripture study journal, write one specific way you can improve in your efforts to learn by the Spirit.

How can you tell when you are teaching and learning by the Spirit?

Read Doctrine and Covenants 50:21–22, looking for the Lord’s instruction about how to determine if you are teaching and learning by the Spirit.

How would you summarize the Lord’s teaching in those verses? \_\_\_\_\_

In Doctrine and Covenants 50:23–25, notice the difference between what happens when people teach by the Spirit and what happens when people teach and learn by “some other way” (D&C 50:17).

How did the Lord describe teaching that does not edify? How did He describe teaching that “is of God” (D&C 50:24)?



From these verses we can learn the following principle: **That which comes from God enlightens and edifies, but that which is not of God brings confusion and darkness.**

When have you seen or felt that something was not of God? How did the Spirit help you recognize that?

At times you will hear and see messages that are intended to damage your faith. The principles you are learning today can fortify you against those messages. Pray for the Spirit in all of your learning, and give special attention to the influence of teaching by the Spirit. In Doctrine and Covenants 50:13–22, we learn that **when we teach and learn by the Spirit, we understand one another and we are edified and rejoice together.** This is different than the confusion and darkness when something is taught “some other way.”

In Doctrine and Covenants 50:26–36, read the Lord’s counsel to priesthood holders regarding the power and responsibilities that come with their ordination. He said that priesthood holders are to serve others and keep themselves pure. As they do so, the Lord will give them power to overcome false spirits like those that were found among some of the Saints.

### Doctrine and Covenants 50:37–46

*The Lord encourages His servants to continue growing in grace and truth, and He assures them He is with them*

Imagine the young children of your ward or branch serving full-time missions when they are older. What do they need to be prepared to serve? In what ways are we like these young children?

In Doctrine and Covenants 50:37–46, the Lord spoke specifically to some of the elders who were serving in 1831. However, His words also apply to us. Study Doctrine and Covenants 50:40–46, looking for words or phrases of comfort and assurance. Consider marking what you find.

In Doctrine and Covenants 50:40, the Lord said “ye must grow in grace.” What do you think it means to “grow in grace”?

As you think about this question, you may want to read the definition of *grace* in the Bible Dictionary or in *True to the Faith*. What we learn in Doctrine and Covenants 50:37–46 helps us know that **the Savior wants us to grow in grace and in the knowledge of the truth and to have confidence in Him.** Just as



He promised those elders, He will watch over us as we trust Him and seek to do His will.

What does it mean to you when the Lord says, “You are mine”? How can this assurance help us to “fear not” (D&C 50:41)?

What other promises in Doctrine and Covenants 50:40–46 are meaningful to you?



**5.** Write the following at the bottom of today’s assignments in your scripture study journal:

*I have studied Doctrine and Covenants 50 and completed this lesson on (date).*

*Additional questions, thoughts, and insights I would like to share with my teacher:*

# Doctrine and Covenants 51–52

## Introduction

As some of the Saints migrating from the eastern states began to arrive in Ohio in May 1831, the Lord revealed His will to Bishop Edward Partridge through the Prophet Joseph Smith. In that revelation, recorded in Doctrine and Covenants 51, the Saints arriving from Colesville, New York, were directed to go to Thompson, Ohio, where they would live the law of consecration. Consecration and stewardship are the principles and law upon which a Zion society is based. The United Firm (later called the United Order) was the organization used to administer that law then. At the close of the fourth conference of the Church, held June 3–6, 1831, in Kirtland, Ohio, the Lord commanded Joseph Smith and other elders to travel in pairs to Missouri, preaching along the way. In the revelation recorded in Doctrine and Covenants 52, the Lord called each companionship and gave a pattern to help them avoid deception.

## Doctrine and Covenants 51

*The Lord directs Bishop Edward Partridge to address the temporal needs of the Saints*

What is the most unified group you have been a part of? How do you know if a group of people is unified? What types of practices or events help a group become unified?

As the Saints arrived in Ohio, the Lord revealed to them the law of consecration (see Doctrine and Covenants 42:30–42). Under this law, men and women voluntarily dedicate their time, talents, and earthly wealth to the establishment and building up of God’s kingdom. Read the section introduction to Doctrine and Covenants 51, looking for what Bishop Edward Partridge was responsible to do in connection with this law.

Doctrine and Covenants 51:1–8 contains instruction from the Lord to Bishop Partridge concerning the incoming Saints. The Lord told Bishop Partridge to “appoint unto this people their portions” of land and substance “according to [their] circumstances and [their] wants and needs” (D&C 50:3). (Note that one definition of the word *want* is to lack something. The Lord’s command to act “according to the wants of the people” was a command to help people obtain

the necessities they did not have.) Bishop Partridge was to give full ownership of the properties to the families and ensure that everyone had enough food and clothing.

The Lord explained how the Saints should act while living the law of consecration. Read Doctrine and Covenants 51:9, looking for the Lord’s instructions to the Saints.



1. Answer the following questions in your scripture study journal:

- What does it mean for a group of people to “be one”? (You may want to read Moses 7:18 for help with answering this question.)
- According to Doctrine and Covenants 51:9, what did the Lord instruct the Saints to do in order to become united? What do you think it means to “be alike” and “receive alike”?

As you read Doctrine and Covenants 51:10–20, you will see that the Lord instructed Bishop Partridge to establish a storehouse where the Saints could keep surplus goods. The Lord declared that living the law of consecration was a privilege. He explained that although the Saints would be living on their land for only a short period of time, they should plan to be faithful, wise, and just stewards of what they had been given.

## Doctrine and Covenants 52:1–13, 22–34

*The Lord commands the Prophet and other elders to travel to Missouri and to preach the gospel during their journey*

In Doctrine and Covenants 52:1–13, 22–34 the Lord instructed the Prophet Joseph Smith and other elders to travel two by two to Missouri and to preach along the way. The Lord had previously revealed that the Saints would establish a united community called Zion (see D&C 28:9), but He had not revealed its location. In the revelation recorded in Doctrine and Covenants 52, He promised them that if Joseph Smith and Sidney Rigdon were faithful to His instructions, He would reveal to them the location of “the land of [the Saints’] inheritance” (D&C 52:5).

## Doctrine and Covenants 52:14–21, 35–36

*The Lord reveals a pattern to help us avoid being deceived by Satan*

In the revelation recorded in Doctrine and Covenants 50, the Lord warned some elders of the Church about false spirits and gave instructions that would help the Saints edify one another as they taught and learned gospel truths.

As you study Doctrine and Covenants 52:14–21, look for further instructions from the Lord to help strengthen Church members, particularly those whom He had called to preach the gospel as they traveled to Missouri. Read Doctrine and Covenants 52:14, and identify the phrase the Lord used to describe what He was about to give these missionaries.



**2.** Answer the following questions in your scripture study journal:

- a. What do you think is the purpose of a pattern?
- b. What reason did the Lord give for providing the pattern recorded in Doctrine and Covenants 52:14–21?

Read Doctrine and Covenants 52:15–19, looking for actions and attributes that the Lord said would help His people avoid being deceived by Satan. As you seek to understand the Lord’s instruction in these verses, consider the following explanations:

- A person “whose spirit is contrite” (D&C 52:15) has a repentant attitude.
- The command to “obey mine ordinances” (D&C 52:15) refers to the need to receive priesthood ordinances, such as baptism, and to keep the associated covenants.
- A person “whose language is meek and edifieth” (D&C 52:16) is someone whose speech is humble and lifts or builds others.
- A person who “trembleth under [the Lord’s] power” (D&C 52:17) is a person who feels reverence for the power of God.
- To “bring forth fruits” (D&C 52:17) is to produce something good (such as “praise and wisdom”) by following the revelations God has given.

The following principle summarizes insights learned from this revelation: **In order to avoid being deceived by Satan, a person must obey the Lord’s ordinances and live according to the revelations He has given.**

Read Doctrine and Covenants 52:36, looking for additional instruction the Lord gave. What did the Lord instruct the elders of the Church to declare?



**3.** In your scripture study journal, write about a leader or teacher you know who lives according to the pattern the Lord outlined in Doctrine and Covenants 52:14–19, 36. In what ways have you benefited from this person’s teachings and example?

Think about members of the First Presidency and the Quorum of the Twelve Apostles, and consider how they demonstrate the Lord’s pattern for not being deceived by Satan.

## Doctrine and Covenants 52:37–44

*The Lord gives counsel to leaders who remain in Ohio*

While the Lord called many of the early priesthood holders to preach on their way to Missouri or elsewhere, He commanded other elders to stay in Ohio. Read Doctrine and Covenants 52:39–40, looking for the instructions the Lord gave to the elders who would remain in Ohio. (As you read, it might be helpful to know that the word *residue* refers to those who remained.) Consider marking what you find.

Think about the following questions: What do you think it means to “remember in all things the poor and the needy” (D&C 52:40)? Why is just thinking about someone in need not enough to fulfill this commandment from the Lord?

In Doctrine and Covenants 52:40, what did the Lord say about people who refuse to help those in need?

Based on this verse, complete the following truth:

**Disciples of Jesus Christ watch over and care for**

---



**4.** Think about those you know whom you would consider to be disciples of Jesus Christ. In your scripture study journal, write about how these people watch over and care for those in need.

Think about times when you have had opportunities to care for the poor, needy, sick, and afflicted. Consider setting a specific goal to meet someone’s needs and be a better disciple of Jesus Christ.



**5.** Write the following at the bottom of today’s assignments in your scripture study journal:

*I have studied Doctrine and Covenants 51–52 and completed this lesson on (date).*

*Additional questions, thoughts, and insights I would like to share with my teacher:*

# Doctrine and Covenants 53–56

## Introduction

In June 1831, the Prophet Joseph Smith received the revelations recorded in Doctrine and Covenants 53–55. The revelations contained the Lord’s instructions for some Church members who lived in Ohio but would soon move to Missouri. In these revelations the Lord spoke to Sidney Gilbert, Newel Knight, and William W. Phelps, giving them instructions that were specific to their Church assignments and their talents.

## Doctrine and Covenants 53

*The Lord calls Sidney Gilbert to be an elder and travel with Joseph Smith to Missouri*

After Sidney Gilbert found that his name was not on the list of missionaries called to travel to Missouri (see D&C 52:22–32), he went to the Prophet Joseph Smith and asked what the Lord would have him do. Joseph inquired of the Lord and received the revelation recorded in Doctrine and Covenants 53. In the revelation, the Lord instructed Brother Gilbert to be ordained an elder and to act as an agent to Bishop Edward Partridge. Brother Gilbert’s role as an agent to the bishop is explained more completely in Doctrine and Covenants 57:6–10, 15. The Lord also commanded Sidney to go to Missouri with Joseph Smith and Sidney Rigdon.

Consider the following experience of a young woman who also wondered what the Lord wanted her to do:

“It was in China that Aleisha Cramer got the answer to her prayers. The answer was simple yet hard to do at the same time. She was supposed to give up her lifelong dreams, go home, and live the life of an average college student. The answer surprised her, but she was willing to do the things the Lord told her to do.

“Aleisha . . . had made it to the top as a star soccer player. She had reached most of her goals, working her way up to become a member of the United States national women’s team, giving her a chance to play in the World Cup and the 2004 Olympics.

“She had it made. But it wasn’t making her happy.



“‘I had everything,’ said Aleisha. ‘I had a good family. I had friends. I was going to school at BYU. I was playing really well for the national team. But would I keep working towards making the World Cup team and still feel this emptiness?’

“Then, while in China to play exhibition games, Aleisha woke up one night crying. She felt a wonderful warm, comfortable feeling. ‘I remember putting my hand on my heart, and then I just had all these thoughts: “You need to quit the national team. It’s not okay for you to break the Sabbath day. It’s okay for you to take a different path. Things will work out.”’ She describes being filled with the Spirit and having the experience repeated several nights in a row.

“Although she had been a member of the Church her whole life, Aleisha’s interest in the gospel had been increasing. She was reading her scriptures at least 30 minutes every day, and she had noticed that her prayers were changing. She was asking the Lord what He wanted her to do. And in China, she received her answer.

“‘I’ve never had those feelings before, the comfort and the warmth. I wish I could have those experiences every time I have questions. Everything seemed so clear. It made so much sense.’



"Aleisha acted on the inspiration she received. She said, 'When you get inspiration, you have to follow it right then. If I had said, "Yes, that's right. But I really want to play in the World Cup, so I'll do it after that," then things may not have worked out like they were supposed to.' . . .

"Not being on the national team gave Aleisha time to try some new things." It was during this time that she began dating a young man who was teaching her to play the guitar, and they were later married in the temple.

"I am sure that I was prepared for this change by what happened in China. I gave something up and got something way better," Aleisha says.

". . . She still wants to work hard, but now it will be working hard for her own family.

"[Aleisha] is listening to the greatest coach of all, her Heavenly Father, the one who can help guide her and give her direction and inspiration. As Aleisha said, "The Lord knows each of us. For me that's so good to know and have a testimony of" (Janet Thomas, "The Playmaker," *New Era*, Nov. 2003, 21, 23).

Ponder ways you can receive direction from the Lord about your life.

## Doctrine and Covenants 54

### *The Lord instructs Newel Knight to lead the Colesville Saints to Missouri*

In April 1831, Newel Knight led a group of Saints from Colesville, New York, to join the Saints in Ohio. In May, the Prophet Joseph Smith instructed Bishop Edward Partridge to have those Saints settle on land in Thompson, Ohio, that Lemam Copley had previously covenanted (or promised) to give for that purpose. They planted crops there and started making other improvements on the property. But even as they worked together to improve the land, they began to be selfish and greedy. Their situation worsened when Lemam Copley returned from his mission to the Shakers (see D&C 49) and began doubting his faith. He rejected his developing testimony of the restored gospel and ordered the Saints to leave the land. He also charged them \$60. Because Lemam had broken his covenant, these Saints now had nowhere to live. Newel Knight and others asked the Prophet what they should do.

Read Doctrine and Covenants 54:1–3, and mark what the Lord wanted these Saints to do to help improve their situation. Then ponder the following question: Why do you think repentance and humility would help these Saints?

Read Doctrine and Covenants 54:6, and mark a blessing that was given to those who kept the covenant to consecrate their properties.

Based on the Lord's teachings in Doctrine and Covenants 54:1–6, complete the following principle:

**If we keep our covenants and obey the Lord's commandments, we will obtain \_\_\_\_\_.**

Every blessing we receive is an act of the Lord's mercy. One example of the Lord's mercy is when He forgives us of our sins. When we keep the covenants we make at baptism and obey God's commandments, we will not only receive mercy in this life but will be extended mercy at the Final Judgment.



Elder David A. Bednar of the Quorum of the Twelve Apostles taught some ways that the Lord extends mercy to us as we keep our covenants:

"The Lord's tender mercies are the very personal and individualized blessings, strength, protection, assurances, guidance, loving-kindnesses, consolation, support, and spiritual gifts which we receive from and because of and through the Lord Jesus Christ. . . .

". . . The Lord's tender mercies do not occur randomly or merely by coincidence. Faithfulness, obedience, and humility invite tender mercies into our lives, and it is often the Lord's timing that enables us to recognize and treasure these important blessings" ("The Tender Mercies of the Lord," *Ensign* or *Liahona*, May 2005, 99–100).



**1. In your scripture study journal, write about some of the blessings you feel the Lord has given you recently because of your faithfulness to your covenants and obedience to His commandments.**

In Doctrine and Covenants 54:7–10 we read that after these Saints lost their homes on Lemam Copley's land, the Lord commanded them to travel to Missouri. They were to appoint someone to pay for expenses along the way and to work for their living there until the Lord would prepare a place for them to settle. The Lord also counseled them to be patient in tribulation.

## Doctrine and Covenants 55

*The Lord calls William W. Phelps to assist in the writing and printing of Church materials*

Think of some of your talents or skills. Then think of some talents or skills one of your friends has. Because of the variety of our abilities, we can help in the Lord's work in different ways. **God can use our talents, skills, and abilities to bless His children.** William W. Phelps is an example of this principle. Before he arrived in Kirtland, Ohio, he had purchased a copy of the Book of Mormon two weeks after it was offered for sale. This led to his conversion.

Read the section introduction for Doctrine and Covenants 55, looking for one of William W. Phelps's skills or abilities. Then read Doctrine and Covenants 55:4, looking for another of his talents. The Lord called Brother Phelps to use his talents and skills to help with the writing and printing of Church materials in Missouri (see D&C 55:5). Brother Phelps's efforts there blessed the Church in many ways.



 **2.** Answer the following questions in your scripture study journal:

- How have you seen the Lord use people's talents and abilities to bless others?
- How might your talents or abilities bless and lift others and move the Lord's work forward?

## Doctrine and Covenants 56:1–13

*The Lord revokes Ezra Thayre's mission call and warns him to repent*

 **3.** Write in your scripture study journal about someone you know who gave up something important to him or her in order to obey a commandment. (Examples could include someone sacrificing to join the Church, to go on a mission, or to obey certain Church standards.)

Ezra Thayre had been assigned to live and work with Joseph Smith Sr. on Frederick G. Williams's farm in Kirtland, Ohio. In addition to working on the farm, Ezra also helped pay for some of the debt owed on the land. When he was called on a mission to Missouri with Thomas B. Marsh (see D&C 52:22), he demanded a deed to the portion of the Church's land to which he felt entitled. Because of his concerns over his property and money, Ezra Thayre was not prepared to leave on that mission when Thomas was ready, so Thomas went to the Prophet Joseph Smith and asked what he should do.

In the revelation recorded in Doctrine and Covenants 56, the Lord revoked Ezra Thayre's mission call and assigned a new companion for Brother Marsh. The Lord then warned against pride and taught the Saints that He has much more in store for them than land and money.

Read Doctrine and Covenants 56:3–5, looking for what happened because Ezra Thayre was not ready to go with Thomas B. Marsh to Missouri. As you read, it might be helpful to know that the word *revoke* means to take back or cancel. What did Ezra lose because he was not ready to go with Brother Marsh?

Doctrine and Covenants 56:4 teaches us that **the Lord can command or revoke a commandment as He sees fit**. You may want to mark the words or phrases that indicate this principle.

The following are a few examples from the scriptures and Church history of the Lord giving or revoking a command:

- After the Lord offered a higher law to Moses and his people, the children of Israel rebelled and began worshipping a golden calf. The Lord then gave them a lesser law. (See Joseph Smith Translation, Exodus 32:14; 33:20; 34:1–2 [in the Bible appendix].)
- During the Savior’s ministry on earth, He told the Apostles to preach only to the Jews (see Matthew 10:5). Shortly after the Savior’s death, Peter received a revelation that it was time to preach the gospel to people of all nations (see Matthew 28:19).
- In this dispensation the Lord commanded some of the early Saints to practice plural marriage. The Prophet Joseph Smith and many other Church leaders found this commandment difficult, but they obeyed it. Years later, after receiving revelation, President Wilford Woodruff issued a written statement—the Manifesto—which was accepted by the Church as authoritative and binding on October 6, 1890. This led to the end of the practice of plural marriage in the Church (see Official Declaration 1).

Read Doctrine and Covenants 56:8–11, looking for what the Lord commanded Ezra Thayre to do after his mission call was revoked. Fortunately, Ezra chose to repent, and seven months later he was again called to serve as a missionary with Thomas B. Marsh (see D&C 75:31).

## Doctrine and Covenants 56:14–20

### *The Lord warns the Saints against greediness and prideful hearts*

Sometimes people think that pride is a characteristic found only in the hearts of the rich. However, this is not always true, as you will learn in the following verses.

Read Doctrine and Covenants 56:16–17, looking for how an unrepentant heart can be manifest both in someone who is rich and in someone who is poor. Consider marking what you find. Ponder why pride and greed can be common traits in both the rich and the poor.

Read Doctrine and Covenants 56:18, looking for the Lord’s description of the hearts and spirits of those who will be blessed. Use the footnotes to understand some of the words the Lord used.



Elder D. Todd Christofferson of the Quorum of the Twelve Apostles taught: “As you seek the blessing of conversion, you can offer the Lord the gift of your broken, or repentant, heart and your contrite, or obedient, spirit. In reality,

it is the gift of yourself—what you are and what you are becoming” (“When Thou Art Converted,” *Ensign*, May 2004, 12).

Read Doctrine and Covenants 56:19–20, looking for blessings the Lord promised to those with humble hearts. It may help you to know that the Lord’s “recompense” means that He will make payment for every good and every evil that has been done.



**4.** Answer the following questions in your scripture study journal:

- How do the blessings described in Doctrine and Covenants 56:18–20 compare to the property and money Ezra Thayre and other early Saints may have been concerned about?
- What can you do to have the kind of heart that will receive the blessings listed in these verses?



**5.** Write the following at the bottom of today’s assignments in your scripture study journal:

*I have studied Doctrine and Covenants 53–56 and completed this lesson on (date).*

*Additional questions, thoughts, or insights I would like to share with my teacher:*

# The Center Place of Zion

## Introduction

This lesson provides an overview of a few of the events in Church history that occurred in Jackson County, Missouri. In the summer of 1831, some of the Saints who had gathered in Ohio began their journey to settle in the area of Jackson County, Missouri. In a revelation to the Prophet Joseph Smith in July 1831, the Lord designated the town of Independence, Missouri, as the “center place” of Zion (D&C 57:3). The Saints began building up the city and endeavored to live according to the laws of God. Over time, however, contentions arose between the Saints and other citizens of Missouri, which led to mob violence against the Saints. The Saints were forced to leave Jackson County in November and December of 1833.

## The Lord designates Independence, Missouri, as the center place of Zion

Imagine you are camping and you learn that a storm is approaching. What are some ways you might find protection from the storm? How might a tent be helpful in this situation?

In the Old Testament, the prophet Isaiah used the analogy of a tent to represent Zion being built up in the last days as a protection for the Saints (see Isaiah 54:2). The Israelites used tents for their shelter and rest when they were living and traveling in the wilderness. President Ezra Taft Benson taught about the symbolism associated with tents:

“Picture in your mind a great tent held up by cords extended to many stakes that are firmly secured in the ground.

“The prophets likened latter-day Zion to a great tent encompassing the earth. That tent was supported by cords fastened to stakes. Those stakes, of course, are various geographical organizations spread out over the

earth. Presently, Israel is being gathered to the various stakes of Zion” (“Strengthen Thy Stakes,” *Ensign*, Jan. 1991, 2).

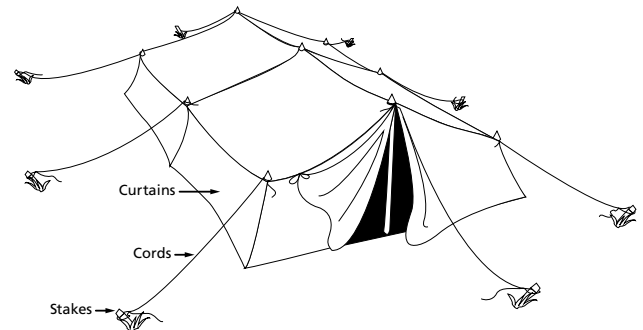

Read Doctrine and Covenants 115:6, looking for the kind of protection the Lord promised to those who would gather to Zion in the last days. You may want to mark what you find.

The early Saints thought of Zion as a place of peace, safety, and protection from the wicked (see D&C 45:66–71). They had been anxiously waiting for the Lord to reveal the location of Zion so they could begin building His holy city. In July 1831, the Lord declared that the land of Missouri was the promised land of Zion and that Independence, Missouri, was the “center place” of the city of Zion (see D&C 57:1–3).



1. Answer the following questions in your scripture study journal:

- If you had been an early Church member, how might you have felt after learning where the city of Zion would be built?
- When would you have wanted to begin building the city? Why?

Have you ever set up a tent incorrectly or tried to set one up without all of the parts? What happened, or what do you think would happen?

Just as a tent must be set up in a particular way and with all the right parts, Zion must be built up according to a specific pattern. Read Doctrine and Covenants 105:5, looking for how the “tent” of Zion must be built for the Lord to accept it.

Notice that **Zion must be built upon principles of righteousness**. After the Lord revealed the location of the land of Zion in 1831, He gave multiple revelations over the next two years describing the principles upon which the Saints should build Zion.





Read the following scripture passages, looking for the principles of righteousness and commandments the Saints would need to follow to successfully build Zion. In the space provided, write some of the principles and commandments you find.

Doctrine and Covenants 82:14–19 \_\_\_\_\_

\_\_\_\_\_

\_\_\_\_\_

\_\_\_\_\_

Doctrine and Covenants 97:10–16 \_\_\_\_\_

\_\_\_\_\_

\_\_\_\_\_

\_\_\_\_\_

Doctrine and Covenants 97:21–22, 25–27 \_\_\_\_\_

\_\_\_\_\_

\_\_\_\_\_

\_\_\_\_\_

Doctrine and Covenants 133:4–9 \_\_\_\_\_

\_\_\_\_\_

\_\_\_\_\_

\_\_\_\_\_



**2.** Answer the following questions in your scripture study journal:

- a. In what ways might living these principles of righteousness have helped the Saints build Zion and be protected from spiritual storms?
- b. How might living these principles help protect us today?

### Contention arises between the Saints and other Missouri citizens

After the Lord revealed the location of Zion in July 1831, many of the Saints traveled the nearly 900 miles from Kirtland, Ohio, to Independence, Missouri, to settle and build Zion.

Look back at the illustration of the tent at the beginning of the lesson. Ancient tents were often expandable in order to accommodate growing families. In partial fulfillment of Isaiah’s prophecy that the borders of the tent of Zion would be enlarged, the cords lengthened, and the stakes strengthened, Kirtland, Ohio, was designated as “a stake to Zion” (D&C 82:13) after the center place of Zion was established in Independence, Missouri. Both in the early Church and in the Church today, Saints who gather to stakes of Zion receive the protective blessings of Zion. This means that Saints living in stakes of Zion can enjoy the same blessings and protection as those who live at the center place of Zion.

Read the following information about how the Saints in the Kirtland stake of Zion supported the building of the center place of Zion in Missouri. Look for what the Saints in Kirtland did to help establish Zion. You may want to mark some of the insights you find helpful.

**Kirtland, Ohio:** During a series of conferences held in November 1831, the Prophet Joseph Smith and other Church leaders compiled the revelations that had been received up to that point and planned to print them in book form. Oliver Cowdery and John Whitmer received the responsibility to take the revelations to Missouri so William W. Phelps could print them as the Book of

Commandments. During 1831–32, Joseph continued receiving revelations and working on his inspired translation of the Bible. In the spring of 1832, he took a trip to Missouri to visit the Saints in Zion, to warn them that Satan was seeking “to turn their hearts away from the truth” (D&C 78:10), and to coordinate the efforts of the bishop’s storehouses in Kirtland and Independence. Many of the Saints continued to move to Zion, and by the end of 1832 about one third of the members of the Church lived in Jackson County, Missouri. In the early Church, the Saints in Ohio and the Saints in Missouri worked together to contribute funds and resources to build the city of Zion.

Ponder the ways in which the Prophet Joseph Smith and the other Saints in Ohio helped the Saints in Missouri establish Zion.

Read the following information about Independence, Missouri, looking for what prevented the Saints from building Zion. You may want to mark some of the insights you find helpful.

**Independence, Missouri:** Parley P. Pratt described the settling of the Saints in Zion by declaring that “peace and plenty had crowned their labors, and the wilderness became a fruitful field” (*Autobiography of Parley Parker Pratt*, ed. Parley P. Pratt [1938], 93). The Church leaders in Missouri purchased land, set up a store and a printing press, and provided for the needs of the incoming Saints. By July 1833, the population of Latter-day Saints there had increased to almost 1,200. But the Church leaders and the Saints were not without their problems. Some members allowed their selfishness and greed to prevent them from living the law of consecration. Additionally, other settlers in the area became increasingly concerned about the rapid growth of the “Mormons” and their influence on the local economy and politics. Local religious leaders disagreed with the Saints’ beliefs. One religious leader spread lies about the Church members and encouraged the citizens to commit acts of violence against them. The conflict finally exploded over different political views, including the issue of slavery. After W. W. Phelps printed an article entitled “Free People of Color,” the Missouri citizens, who were largely advocates of slavery, incorrectly concluded that the Saints were inviting freed slaves to Missouri. On July 20, 1833, a mob went to Independence, threw the printing press into the street, demolished the printing office, destroyed most of the unbound sheets of the Book of Commandments, tarred and feathered Bishop Edward Partridge and convert Charles Allen, and terrorized the town. Hostilities continued, and the Saints were forced to leave Jackson County in November and December of that year.



Imagine how it might have felt to have been one of the Saints who was hoping for the Lord’s protection but was forced to leave Zion.

 **3.** Based on what you have learned, write in your scripture study journal why the early Saints struggled to build the city of Zion. What can you learn from their experience?

### What is the future of Zion?

Have you ever hoped for or expected something to happen that did not occur? How did you feel?

Imagine the disappointment and confusion the early Saints experienced when the members of the Church were expelled from Jackson County, Missouri. In Kirtland, Ohio, the Prophet Joseph Smith wrote a letter



to the exiled Saints shortly after they fled Jackson County. In it he wrote, “When we learn your sufferings, it awakens every sympathy of our hearts; it weighs us down; we cannot refrain from tears” (in *History of the Church*, 1:454).

In that same letter the Prophet wrote about his inquiring of the Lord about why the Saints’ expectations for Zion had been dashed: “I know that Zion, in the due time of the Lord, will be redeemed; but how many will be the days of her purification, tribulation, and affliction, the Lord has kept hid from my eyes; and when I inquire concerning this subject, the voice of the Lord is: Be still, and know that I am God! All those who suffer for my name shall reign with me, and he that layeth down his life for my sake shall find it again” (in *History of the Church*, 1:453–54).

What did the Lord tell Joseph Smith to do when he inquired about why the Saints had failed to build Zion? Think about how the Lord’s answer to the Prophet’s question could be helpful when things in your life do not go the way you hope or expect them to.

# Doctrine and Covenants 57

Later, the Lord gave more insight into why the Saints' attempt to build the city of Zion failed. Read Doctrine and Covenants 105:5–6, 9–10, 23–24, looking for what the Lord requires of His people before Zion can be established.

So far in this lesson, Zion has referred to a place where the Saints will build a holy city, a New Jerusalem. But the concept of Zion includes more than a specific location where the Saints can find protection. The early Saints may have thought they were only to build a city, but the Lord intended to build a righteous people as well as a city. The protective “tent” of Zion can be found wherever people are obeying the laws of the celestial kingdom (see D&C 105:5).

You may remember from your study of Doctrine and Covenants 97:21 that the Lord explained that **Zion is the pure in heart**. Review again the principles of righteousness and commandments you listed earlier in today's lesson. Think about how these righteous principles help a people to become pure in heart.



Elder David R. Stone of the Seventy explained how we can build up Zion in our day:

“Wherever we are, whatever city we may live in, we can build our own Zion by the principles of the celestial kingdom and ever seek to become the pure in heart. Zion is the beautiful, and the Lord holds it in His own hands. Our homes can be places which are a refuge and protection, as Zion is.

“We do not need to become as puppets in the hands of the culture of the place and time. We can be courageous and can walk in the Lord's paths and follow His footsteps. And if we do, we will be called Zion, and we will be the people of the Lord” (“Zion in the Midst of Babylon,” *Ensign or Liahona*, May 2006, 93).

4. In your scripture study journal, summarize what you have learned in this lesson about Zion. What is your role in building Zion where you live?
5. Consider the principles of righteousness you listed earlier in this lesson. In your scripture study journal, write a goal that will help you live one of them more faithfully.
6. Write the following at the bottom of today's assignments in your scripture study journal:

*I have studied the Center Place of Zion lesson and completed it on (date).*

*Additional questions, thoughts, and insights I would like to share with my teacher:*

## Introduction

In June 1831, the Lord commanded Joseph Smith and other elders to convene a conference of the Church in Missouri (see D&C 52). Obedient to the command, the Prophet Joseph Smith and others traveled approximately 900 miles from Ohio to Missouri. After Joseph arrived in Missouri, he received the revelation now recorded in Doctrine and Covenants 57. In this revelation the Lord revealed the location for the city of Zion, fulfilling a promise He had made earlier to the Saints (see D&C 52). The Lord also instructed several individuals concerning their roles in establishing Zion.

## Doctrine and Covenants 57:1–6

*The Lord reveals the location of the city of Zion*



Read the following statement by the Prophet Joseph Smith to better understand how he felt about establishing and building Zion:

“The meeting of our brethren [Oliver Cowdery, Peter Whitmer Jr., Ziba Peterson, and Frederick G. Williams, all of whom had gone to Missouri as missionaries], who had long awaited our arrival, was a glorious one, and moistened with many tears. It seemed good and pleasant for brethren to meet together in unity. But our reflections were many, coming as we had from a highly cultivated state of society in the east, and standing now upon the confines or western limits of the United States, and looking into the vast wilderness of those that sat in darkness; how natural it was to observe the degradation, leanness of intellect, ferocity, and jealousy of a people that were nearly a century behind the times, and to feel for those who roamed about without the benefit of civilization, refinement, or religion; yea, and exclaim in the language of the Prophets: ‘When will the wilderness blossom as the rose? When will Zion be built up in her glory, and where will Thy temple stand, unto which all nations shall come in the last days?’ Our anxiety was soon relieved by receiving the following [revelation: D&C 57]” (in *History of the Church*, 1:189).

Think of a time when you eagerly anticipated something, such as celebrating a holiday or birthday, serving a mission, visiting the temple, receiving a gift, or visiting a loved one. How did you feel as the event you were anticipating approached? Why was this event so important to you? How did your actions reflect your excitement for this event?

Many of the early Saints anxiously anticipated learning the exact location of the city of Zion. Before the revelation in Doctrine and Covenants 57 was given, they had read in the Book of Mormon about a New Jerusalem that would be located on the American continent (see 3 Nephi 20–21; Ether 13). Through revelations given to the Prophet Joseph Smith, the Saints had learned that Zion would be located somewhere in Missouri (see D&C 52:2, 5, 42).

Remember that three main groups of Church members had been called to travel the nearly 900 miles to Missouri: the Prophet and a small group of elders (see D&C 52–53), a group of missionaries called to preach along the way (see D&C 52), and the Saints from Colesville, New York, led by Newel Knight (see D&C 54).

Read Doctrine and Covenants 57:1–3, and mark where the city of Zion was to be built.

According to those verses, where was the city of Independence located in relation to Zion?

Reread Doctrine and Covenants 57:3, and mark what the Lord said should be located in Independence, or the center place of Zion.

You might want to write the following principle in the margin of your scriptures: ***The temple is in the center place of Zion.***

 **1.** Answer the following questions in your scripture study journal:

- a. Why do you think it was important for a temple to be located in the center place of Zion?
- b. Why might it be important to have the temple at the center of our lives?

Think about things that can distract individuals from receiving the blessings of the temple. What might happen to people who choose to center their lives on worldly things?

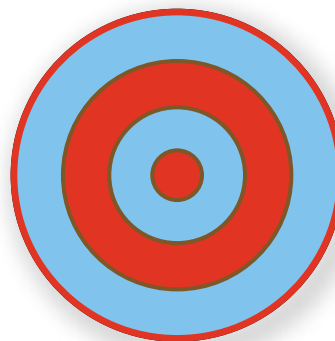

 **2.** In your scripture study journal, draw a target with a bull's-eye in the center. Label the center of your target with the word *temple*. Then answer the following questions:

- a. How might your life be different if you more fully centered it on spiritual things, like the temple?
- b. How might putting the temple at the center of our lives help us to center our lives on Jesus Christ?

Read the following statements describing blessings you can receive as you center your life on the temple. As you read, mark any of these blessings you have experienced.

“To you who are worthy and able to attend the temple, I would admonish you to go often. The temple is a place where we can find peace. There we receive a renewed dedication to the gospel and a strengthened resolve to keep the commandments” (Thomas S. Monson, “Until We Meet Again,” *Ensign or Liahona*, May 2009, 113).

“Sometimes our minds are so beset with problems and there are so many things clamoring for attention at once that we just cannot think clearly and see clearly. At the temple the dust of distraction seems to settle out, the fog and the haze seem to lift, and we can ‘see’ things that we were not able to see before and find a way through our troubles that we had not previously known” (Boyd K. Packer, “The Holy Temple,” *Ensign*, Oct. 2010, 35).



“As we touch the temple and love the temple, our lives will reflect our faith. As we go to the holy house, as we remember the covenants we make therein, we will be able to bear every trial and overcome each temptation. The temple provides purpose for our lives. It brings peace to our souls” (Thomas S. Monson, “Blessings of the Temple,” *Ensign*, Oct. 2010, 15).





“If we are a temple-going people, we will be a better people. . . . I know your lives are busy. I know that you have much to do. But I make you a promise that if you will go to the house of the Lord, you will be blessed, life will be better for you” (Gordon B. Hinckley, “Excerpts from Recent Addresses of President Gordon B. Hinckley,” *Ensign*, July 1997, 73).

“Let us be a temple-attending and a temple-loving people. Let us hasten to the temple as frequently as time and means and personal circumstances allow. Let us go not only for our kindred dead, but let us also go for the personal blessing of temple worship, for the sanctity and safety which is provided within those hallowed and consecrated walls. The temple is a place of beauty, it is a place of revelation, it is a place of peace. It is the house of the Lord. It is holy unto the Lord. It should be holy unto us” (Howard W. Hunter, “The Great Symbol of Our Membership,” *Ensign*, Oct. 1994, 5).



 **3.** Answer the following questions in your scripture study journal:

- a. Which of the blessings mentioned in the statements above have you experienced?
- b. How have these blessings influenced your life?

Ponder what you can do to more completely make the temple the center of your life. Make a goal to remain or become worthy of a temple recommend and to attend the temple as often as your circumstances allow.

Doctrine and Covenants 57:4–6 records that the Lord commanded the Saints to purchase property in and around Jackson County, Missouri, which would enable them to begin to establish Zion and build a temple.

## Doctrine and Covenants 57:7–16

*The Lord instructs individuals concerning their roles in establishing Zion*

Imagine that you were with the Saints in Missouri when the Lord revealed the location of Zion and that you were asked to remain there to help establish the city in Independence. How would you feel knowing you had such an important responsibility? How would you start building up a city unto the Lord? Who would you want to help you build it?

 **4.** Read Doctrine and Covenants 57:7–13. In your scripture study journal, list the names of the four men the Lord assigned to help establish Zion and what He assigned each of them to do.

Each person who was counseled to settle in Missouri had gifts and talents that were needed to help establish Zion. You might want to write the following principle in the margin of your scriptures: ***We should use our individual strengths to help build the Lord’s kingdom as He calls upon us to do so.***

Think of people you know who build the Church by using their personal strengths, spiritual gifts, or skills.

 **5.** Answer the following questions in your scripture study journal:

- a. What are your strengths?
- b. How could you use your strengths to bless your family and the Church?

 **6.** Write the following at the bottom of today’s assignments in your scripture study journal:

*I have studied Doctrine and Covenants 57 and completed this lesson on (date).*

*Additional questions, thoughts, and insights I would like to share with my teacher:*

# Doctrine and Covenants 58

## Introduction

On August 1, 1831, less than two weeks after the Lord designated Independence, Missouri, as the center place of Zion, the Prophet Joseph Smith received the revelation in Doctrine and Covenants 58. This revelation was given in response to those who were anxious to know the will of the Lord concerning them in this new land. In this revelation the Lord counseled the Saints to be faithful in their tribulations and explained why He had sent them to Zion. The Lord also encouraged the Saints to use their agency to bring about righteousness.

## Doctrine and Covenants 58:1–13

*The Lord counsels the Saints to be faithful in their tribulations*

What are some of the challenges you are currently facing in your life?

As you read the following paragraph, look for challenges the Saints faced in Missouri in 1831:

In January 1831, missionaries found a group of Delaware Indians living in the Indian Territory beyond the western border of Missouri. The Delaware Indians were interested in learning the gospel contained in the Book of Mormon. However, because the missionaries had not obtained the required permits to enter the Indian Territory and preach the gospel, and because of opposition from local Indian agents and ministers, the missionaries from the Church were forced to leave the territory. The missionaries then attempted to teach white settlers in Independence, Missouri, and the surrounding areas, but fewer than 10 converts had joined the Church by July 1831. When elders of the Church from Ohio began arriving in Missouri in July 1831, some were disappointed with what they found. Some of them expected to see a rapidly growing community of believers and a settlement that was prepared to accommodate the migrating Church members. A few expressed concern because the land in Independence was undeveloped and would require a great deal of effort to cultivate. Some of the brethren were encouraged to stay in Missouri and purchase lands to prepare Zion for the Saints who would come later.

Read Doctrine and Covenants 58:1–2, looking for what the Lord told the elders that may have helped them feel better about the challenges they faced.

From what you learned in verse 2, complete the following principles:

**We will be blessed if we** \_\_\_\_\_  
 \_\_\_\_\_  
 \_\_\_\_\_

**Our eternal reward will be greater if we** \_\_\_\_\_  
 \_\_\_\_\_  
 \_\_\_\_\_

Read Doctrine and Covenants 58:3–5, looking for what we often fail to see or understand when we are going through trials.

The Lord counseled the elders to have faith in Him and to look beyond the trials they were enduring and focus instead on the glorious future they would experience if they were faithful. The Lord’s message to the Saints in Missouri can help us endure challenges by keeping us focused on the blessings promised to those who endure tribulation faithfully.



**1. Answer one or both of the following questions in your scripture study journal:**

- a. How can trusting that the Lord will bless you help you endure tribulation faithfully?**
- b. When have you felt that you were blessed for being faithful during tribulation?**

In Doctrine and Covenants 58:6–13, the Lord revealed some ways the Saints would be blessed for their obedience in helping to establish Zion. Make a commitment to stay faithful during your challenges so you can receive the rewards the Lord has prepared for you both now and in the future.

## Doctrine and Covenants 58:14–23

*The Lord describes the responsibilities of a bishop and commands the Saints to keep the laws of the land*

The Lord instructed Bishop Edward Partridge and Sidney Gilbert to stay in Missouri to manage the properties of the Church and purchase land in and around Independence, Missouri



Edward Partridge

(see D&C 57:7–8). Bishop Partridge argued with the Prophet Joseph Smith about the quality of the land that had been selected. He felt that different parcels of land should be purchased instead. This disagreement generated hard feelings.

Review Doctrine and Covenants 58:3, and then read Doctrine and Covenants 58:14–15, looking for what the Lord told Bishop Partridge.

 **2.** Answer the following questions in your scripture study journal:

- a. How might the principles taught in Doctrine and Covenants 58:3 have helped Bishop Partridge choose to repent for arguing with the Prophet about which parcels of land should be purchased?
- b. Consider current issues or situations in which some might respond to their Church leaders with “unbelief and blindness of heart” (D&C 58:15). What can you do to avoid making that mistake?

Bishop Partridge accepted the Lord’s rebuke with humility, and he was forgiven of his sins.

Read Doctrine and Covenants 58:16–23, looking for what the Lord directed Bishop Partridge to do to fulfill his calling. According to verses 21–23, what did the Lord instruct the Saints to do? What do these verses teach about those who try to use God’s laws to justify not obeying the laws of the land?

### Doctrine and Covenants 58:24–33

*The Lord counsels the Saints to use their agency to do good*

Imagine that as you are walking down a street you see an elderly person fall. In the following chart, circle what you should do.

Wait for the Spirit to prompt you to help.	Wait to see if someone else is going to help.
Wait for someone to tell you what to do.	Go help the person who fell.

Why did you choose that answer? \_\_\_\_\_

\_\_\_\_\_

\_\_\_\_\_

Read Doctrine and Covenants 58:24–28, looking for principles the Lord taught the Saints as they faced the challenge of building the city of Zion. You may want to mark the principles you discover. One principle taught in these verses is that **we should be anxiously engaged in choosing to do good things and in bringing to pass righteousness.** (The phrase “he that is compelled in all things” [D&C 58:26] refers to

someone who will not act unless he or she is required to do so. Doctrine and Covenants 58:27 is a scripture mastery scripture. You may want to mark it in a distinctive way so you can locate it in the future.)

 **3.** Answer the following questions in your scripture study journal:

- a. What “reward” are these verses referring to? How can doing many good things of our own free will affect whether we receive eternal life?
- b. What are some ways you can be anxiously engaged in doing good at home? At school? In your ward or branch?

Read Doctrine and Covenants 58:29–33, looking for what happens to those who do not use their agency to do good or who doubt the Lord’s commandments. Consider marking what you find.

### Scripture Mastery—Doctrine and Covenants 58:27

 **4.** To help you memorize Doctrine and Covenants 58:27, write the first letter of each word in verse 27 in your scripture study journal. Use the letters you wrote to help you recite the passage. Refer to the scripture as needed. Repeat this activity until you can recite the passage using the first letters or until you can recite it from memory. Consider reciting and explaining Doctrine and Covenants 58:27 to a family member or friend.

### Doctrine and Covenants 58:34–65

*The Lord gives instructions concerning Zion and teaches principles of repentance*

How can you know if the Lord has forgiven you of your sins? Read Doctrine and Covenants 58:42–43, and mark what the Lord taught about forgiveness. (Doctrine and Covenants 58:42–43 is a scripture mastery passage. You may want to mark it in a distinctive way so you can locate it in the future.)

Complete the following principle from Doctrine and Covenants 58:42: **If we \_\_\_\_\_, the Lord will forgive us and remember our sins no more.**

The phrase “remember them no more” does not mean that God forgets our sins. God is omniscient, all knowing—He forgets nothing. However, sins that are repented of are forgiven and will be remembered no more by never being mentioned again.

 **5.** Answer the following question in your scripture study journal: What difference do you think it makes when a person believes that the Lord will forgive his or her sins and remember them no more?

# Doctrine and Covenants 59

Doctrine and Covenants 58:43 teaches how we can know if we have repented of our sins. Read this verse, and then complete the following principle: **To repent, we must \_\_\_\_\_ and \_\_\_\_\_ our sins.**

To forsake a sin means to completely turn away from it and stop doing it. As you read the following statement by President Dieter F. Uchtdorf of the First Presidency, think of times when you have repented and felt the Lord's forgiveness: "Once we have truly repented, Christ will take away the burden of guilt for our sins. We can know for ourselves that we have been forgiven and made clean. The Holy Ghost will verify this to us; He is the Sanctifier. No other testimony of forgiveness can be greater" ("Point of Safe Return," *Ensign* or *Liahona*, May 2007, 101).



## Scripture Mastery—Doctrine and Covenants 58:42–43

 **6.** Write the passage in Doctrine and Covenants 58:42–43 on a card or piece of paper, and recite it each time you kneel in personal prayer. Doing so can help you remember this important passage and remind you to pray for help in your efforts to confess and forsake your sins.

 **7.** Write the following at the bottom of today's assignments in your scripture study journal:

*I have studied Doctrine and Covenants 58 and completed this lesson on (date).*

*Additional questions, thoughts, and insights I would like to share with my teacher:*

## Introduction

On August 7, 1831, the Prophet Joseph Smith received the revelation in Doctrine and Covenants 59 while in Jackson County, Missouri. In this revelation the Lord set forth His expectations for the Saints who had recently arrived in Zion, including proper Sabbath-day observance. The Lord also confirmed that those who keep His commandments will receive spiritual and temporal blessings.

## Doctrine and Covenants 59:1–4

*The Lord describes the blessings He will bestow upon the faithful Saints in Zion*

Polly Knight, the mother of Newel Knight, traveled with a group of Saints on the nearly 900-mile journey from Kirtland, Ohio, to Jackson County, Missouri. Sister Knight became gravely ill on the way to Missouri, but she would not agree to stop traveling, expressing that her greatest desire was to set foot on the land of Zion and to be buried there. Her son Newel recorded that at one point in their journey he "bought lumber to make a coffin in case she should die before we arrived at our place of destination—so fast did she fail. But the Lord gave her the desire of her heart, and she lived to stand upon that land" (*Scraps of Biography: Tenth Book of the Faith-Promoting Series* [1883], 70; see also *History of the Church*, 1:199). Sister Knight died within two weeks of her arrival in Jackson County, Missouri (Zion).

 **1.** On the day Polly Knight died, the Prophet Joseph Smith received the revelation recorded in Doctrine and Covenants 59. Imagine you had been asked to give a talk at Sister Knight's funeral. Read Doctrine and Covenants 59:1–2, and find phrases you could share in your talk that might be meaningful to her friends and loved ones. In your scripture study journal, record at least two of those phrases and explain how they relate to Polly Knight.

Notice that in verse 1 the Lord addressed the revelation to the Saints who, like Polly Knight, had obeyed His commandment to come to the land of Zion with an eye single to His glory. You may wish to mark this phrase in your scriptures. To help you better understand what it means to have an eye single to God's glory, try the following activity:



Close your hand into a loose fist (just enough so that your thumb and fingers begin to overlap). Close one eye, and look at the picture of the Savior on this page through the small opening created by your hand. Then open your other eye and look at the picture with both eyes. Notice everything else that is in your field of vision when you use both eyes. What is the difference when you look at the picture with only one eye?

Using what you learned in the activity as an analogy, what do you think it means to have an eye single to the glory of God?



Read Doctrine and Covenants 59:3–4, looking for both the temporal (earthly) and spiritual blessings promised to those who obey the Lord with an eye single to His glory. Notice that in verse 4 the Lord promises to bless his faithful Saints with “commandments not a few.” Why do you think the Lord would promise this blessing when some people do not consider commandments to be a blessing? Ponder how following the commandments has blessed your life.

 **2.** Make two columns on a page in your scripture study journal. Label one column *Temporal blessings* and the other column *Spiritual blessings*. List the blessings you identified in Doctrine and Covenants 59:1–4 in the appropriate column.

In the margin of your scriptures, you may want to write the following principle: ***If we keep the commandments with an eye single to the glory of God, then we will be blessed both temporally and spiritually.*** Look for further examples of this principle as you continue to study Doctrine and Covenants 59.

## Doctrine and Covenants 59:5–8

### *The Lord gives commandments to the Saints*

The Lord continued this revelation by giving the Saints in Zion several commandments. Read Doctrine and Covenants 59:5, and mark the first commandment the Lord gave: **We must love God with all of our heart, might, mind, and strength.**

 **3.** Answer the following questions in your scripture study journal:

- a. What do you think it means to love the Lord with all of your heart, might, mind, and strength?
- b. What are some actions or attitudes you might see in people who love the Lord with all of their heart, might, mind, and strength?

Think about how this commandment to love God with all of our heart, might, mind, and strength can influence the way we respond to all of God’s commandments. Share with a family member or friend a time when your love for the Lord influenced a decision that you made. You might want to ask the person you talk to how loving the Lord has influenced the way he or she responds to His commandments.

Doctrine and Covenants 59:6–8 includes additional commandments the Lord gave the Saints at this time. As you read these verses, ponder how keeping these commandments can allow us to demonstrate our love for the Lord.

In Doctrine and Covenants 59:6, the Lord referred to murder and stated that we should not “do anything like unto it.” How is abortion “like unto” murder? (See *True to the Faith: A Gospel Reference* [2004], 4–5.)



## Doctrine and Covenants 59:9–19

### *The Lord teaches the Saints about the Sabbath day*

The Lord gave a commandment that could help the Saints put God first in their lives and deepen their relationship with Him. Read Doctrine and Covenants 59:9–10, and identify the commandment the Lord emphasized in these verses.

In verse 9, the Lord promises a great blessing to those who keep the Sabbath day holy. Review verse 9, and identify the promise the Lord gave. It may be helpful to know that to be “unspotted from the world” refers to being clean from the sinfulness of the world. Using what this verse teaches, complete the following principle in your own words: **If we \_\_\_\_\_, it will help us to \_\_\_\_\_.**



Concerning this commandment to keep the Sabbath day holy, Elder Mark E. Peterson of the Quorum of the Twelve Apostles stated: “Our observance or nonobservance of the Sabbath is an unerring measure of our attitude

toward the Lord personally and toward his suffering in Gethsemane, his death on the cross, and his resurrection from the dead. It is a sign of whether we are Christians in very deed, or whether our conversion is so shallow that commemoration of his atoning sacrifice means little or nothing to us” (“The Sabbath Day,” *Ensign*, May 1975, 49).

How do you show the Lord your love for Him on the Sabbath day?

-  **4.** In your scripture study journal, share how keeping the Sabbath day holy has given you or can give you power to become clean and remain clean from the sinfulness of the world.

Doctrine and Covenants 59:9–15 helps us understand the purpose of the Sabbath and what we can do to keep it holy. Read verses 9–15 carefully, looking for insights into how we can keep the Sabbath day holy. For example, in verse 9 you might identify that to “go to the house of prayer” (go to church) is an important part of keeping the Sabbath holy. See what other insights you can discover as you study these verses. (It might be helpful to know that the phrase “pay thy devotions” in verse 10 means to worship or to demonstrate our love and loyalty. Also, footnote 12*b* explains that the word *oblations* refers to offerings of “time, talents, or means, in service of God and fellowman”; the word *means* generally refers to money or resources that are donated to the Church.)

-  **5.** In your scripture study journal, list at least six insights you discovered in Doctrine and Covenants 59:9–15 about keeping the Sabbath day holy. These could include what our actions or attitudes should be or the purposes of the Lord’s holy day. Once you have completed your list, ponder how keeping the Sabbath holy in one of these areas has affected your relationship with the Lord.

### *Making Lists*

Lists can help you organize what you learn from the scriptures so you can remember it and share what you know with others. When making a list, give it a clear title and include sufficient information so you can remember the purpose of the list later.

In Doctrine and Covenants 59:15–19, the Lord promises blessings to those who honor His holy day.

-  **6.** Write a personal goal of what you will do to help yourself keep the Sabbath day holy.

## Doctrine and Covenants 59:20–24

### *The Lord decrees earthly and eternal blessings upon the faithful*

What are some ways God has blessed you recently? Which of your blessings do you feel most grateful for? Read Doctrine and Covenants 59:20–21, and identify how God feels about blessing us and how we should respond. What does it mean to you to know that God is pleased when He blesses you?

Doctrine and Covenants 59:21 teaches us that **we offend God when we do not express our gratitude to Him and keep His commandments.** The offense and wrath of God described in this verse is evidence of His love for us. He is displeased when we are ungrateful or disobedient because these attitudes distance us from Him.

Ponder the ways in which our relationship with God can be damaged when we do not thank Him for our blessings.

The Lord concluded this revelation by repeating His desire to bless us both in this life and in the life to come. Read Doctrine and Covenants 59:23–24, and identify how the Lord will bless those who keep His commandments.

Throughout the rest of the day today or tomorrow, ponder the many ways God has blessed you for keeping His commandments. Look for opportunities to demonstrate your love and gratitude to Him.



7. Write the following at the bottom of today's assignments in your scripture study journal:

*I have studied Doctrine and Covenants 59 and completed this lesson on (date).*

*Additional questions, thoughts, and insights I would like to share with my teacher:*

## UNIT 14: DAY 1

# Doctrine and Covenants 60–62

### Introduction

On August 8, 1831, the Prophet Joseph Smith and 10 elders prepared to leave Independence, Missouri, and return to Ohio. The Lord instructed the elders to preach the gospel as they traveled—instruction that is now recorded in Doctrine and Covenants 60. On the third day of their journey, the company experienced danger on the Missouri River. The next two days, August 12 and 13, the Prophet Joseph Smith received two revelations from the Lord. Those revelations are now recorded in Doctrine and Covenants 61 and 62. They include words of instruction, warning, comfort, and encouragement.

### Doctrine and Covenants 60

*The Lord commands elders to preach the gospel as they travel from Missouri to Ohio*

Think about a time when you hesitated to tell others about your beliefs or were reluctant to share your testimony of the gospel.



The Lord rebuked some of the elders who had traveled to Independence, Missouri. Read Doctrine and Covenants 60:1–2 to learn why the Lord was displeased with some of these elders. You may want to mark what you learn.

The elders described in verses 1–2 had traveled from Ohio to Independence, Missouri, to participate in the dedication of the land and the temple site. The Lord had commanded them to preach the gospel to others as they traveled to Missouri (see D&C 52:9–10). However, some of the elders had not obeyed this commandment. The Lord said, “They will not open their mouths, but they hide the talent which I have given unto them” (D&C 60:1). In other words, they had not shared their testimonies of the gospel.

According to Doctrine and Covenants 60:2, why had some of the elders not shared their testimonies with others? \_\_\_\_\_

Read Doctrine and Covenants 60:3 to find out what can happen if we do not share our testimonies.

You may want to write the following principle in your scriptures: ***We can lose our testimonies if we do not share them.*** Sharing testimonies does not refer only to formal testimonies spoken in Church meetings. Some Church members who never or rarely speak in Church meetings share their testimonies through the type of lives they live. Some testify of the gospel through enduring health trials or other hardships. Others bear testimony informally to family members or friends through expressions of hope and faith.



President Boyd K. Packer of the Quorum of the Twelve Apostles taught about the importance of sharing our testimonies:

“The Spirit and testimony of Christ will come to you for the most part *when*, and



remain with you only *if* you share it. In that process is the *very essence* of the gospel.

“Is not this a perfect demonstration of Christianity? You cannot find it, nor keep it, nor enlarge it unless and until you are willing to share it. It is by giving it away freely that it becomes yours” (“The Candle of the Lord,” *Ensign*, Jan. 1983, 55).



1. Answer the following questions in your scripture study journal:

- a. When have you felt your testimony grow because you shared it?
- b. When might you have an opportunity in the next week or so to share your testimony?

In the rest of Doctrine and Covenants 60, you will read that the Lord commanded these elders to proclaim the gospel as they traveled back to Ohio. As you study, you might underline words and phrases that relate to bearing testimony, such as “declare my word” or “preach.”

## Doctrine and Covenants 61

*The Lord provides direction for the Prophet Joseph Smith and other elders on their journey to Ohio*

The Prophet Joseph Smith and 10 elders found that they were in danger as they traveled by canoe on the powerful currents of the Missouri River. As you read the following account, think about how you might have felt if you had been there.



Missouri River, McIlwaine's Bend

Joseph Smith recalled that on the third day of the journey, “many of the dangers so common upon the western waters, manifested themselves; and after we had encamped upon the bank of the river, . . . Brother [William W.] Phelps, in open vision by daylight, saw the destroyer in his most horrible power, ride upon the face of the waters; others heard the noise, but saw not the vision” (in *History of the Church*, 1:203). Prior to this vision, “some disagreements and ill feeling

had developed among the brethren” (B. H. Roberts, *A Comprehensive History of the Church*, 1:262–63). That evening, the brethren discussed their difficulties, and most of them were able to forgive one another. The following morning, Joseph prayed and received the revelation recorded in Doctrine and Covenants 61.

Read Doctrine and Covenants 61:2, 20, 36–37, and mark phrases that might have brought comfort to these elders.

In addition to forgiving these elders of their sins, the Lord taught that “many destructions” would occur on the waters in the last days (see D&C 61:5, 14–19). The Lord also spoke of His power. Read Doctrine and Covenants 61:1, 6, 10, looking for what the Lord taught about His power.

Because of William W. Phelps’s vision of the destroyer upon the waters, some have assumed that Satan has power over the waters. However, Doctrine and Covenants 61:1 affirms that the Lord has all power. This would include power over the waters. Verses 6 and 10 affirm the Lord’s ability to preserve us. You may want to write the following principle in your scriptures: **The Lord has all power, and He is able to preserve us.**

The rest of Doctrine and Covenants 61 contains further instructions from the Lord to these elders to guide their return to Ohio.

## Doctrine and Covenants 62

*The Lord commends the faithfulness of a group of elders traveling to Independence, Missouri*

In the following chart, place an “X” next to the questions that you think might matter most to the Lord.

	Should I go to Church on Sunday?
	Should I wear a black skirt or a green skirt to Church? Should I wear a red tie or a blue tie?
	Should I serve a mission? If so, when?
	If my mom offers to fix my favorite meal, what should I choose?



Depending on the circumstances, many of the decisions we make may be important to the Lord, while others may not be. In the revelations recorded in Doctrine and Covenants 60–62, the Lord helped the elders of His Church understand that some of the decisions they needed to make mattered more to Him than others. As you continue to study these revelations, you can gain insights to guide you in making decisions.

To understand the setting of Doctrine and Covenants 62, read the section introduction.

The elders mentioned in the section introduction had traveled more slowly to Independence, Missouri, than some of the others because of their diligent efforts to preach the gospel. As a result, they had missed the conference in which the land and the temple site were dedicated.

Read Doctrine and Covenants 62:1–3, looking for some of the blessings that come to those who preach the gospel and share their testimonies.

Study the scripture references listed in the left column of the following chart. In the appropriate columns, write down things that mattered to the Lord and things that did not matter to Him.

	What mattered to the Lord?	What did not matter to Him?
D&C 60:5		
D&C 61:21–22		
D&C 62:5–7		

 **2.** In your scripture study journal, answer the following question about the scriptures you studied in the chart: What differences do you notice between the things that mattered to the Lord and the things that did not matter?



In the following statement by Elder David A. Bednar of the Quorum of the Twelve Apostles, underline words or phrases that help you understand what the Lord was teaching the elders when He said that some things mattered to Him while other things did not matter:

“Clearly, the Savior was not saying to these missionaries that He did not care about what they were doing. Rather, He was emphasizing the importance of putting first things first and focusing upon the right things. . . . The essential thing was the work they had been called to perform; how they got there was important but was not essential” (“A Reservoir of Living Water,” [Church Educational System fireside for young adults, Feb. 4, 2007], 4; LDS.org).

 **3.** Answer the following question in your scripture study journal: How can the pattern of what matters to the Lord and what doesn’t matter to Him guide you as you make decisions?

Read Doctrine and Covenants 62:8, and identify two things we can rely on when making decisions. Then complete the following principle by filling in the blanks: **When we make decisions, we are to rely on \_\_\_\_\_ and \_\_\_\_\_.**

 **4.** Answer the following questions in your scripture study journal:

- a.** Why do you think it is important to rely on our judgment as well as the directions of the Spirit?
- b.** When have you made a decision based on your own judgment as well as direction from the Spirit? How were you blessed for doing so?

Consider how you can act on one or more of the principles you have learned in your study of Doctrine and Covenants 60–62.

 **5.** Write the following at the bottom of today’s assignments in your scripture study journal:

*I have studied Doctrine and Covenants 60–62 and completed this lesson on (date).*

*Additional questions, thoughts, and insights I would like to share with my teacher:*

# Doctrine and Covenants 63

## Introduction

In the summer of 1831, while the Prophet Joseph Smith was overseeing the dedication of the land where the Saints were to build Zion in Independence, Missouri, some Church members turned away from the Lord’s commandments and committed serious sins. The Prophet returned to Kirtland, Ohio, on August 27, and on August 30 he received the revelation recorded in Doctrine and Covenants 63. In this revelation the Lord warned the Saints about the consequences of wickedness and rebellion, promised blessings to the Saints who are faithful in the last days, and exhorted His servants to remember the sacredness of His name.

## Doctrine and Covenants 63:1–21

*The Lord warns the Saints about the consequences of wickedness and rebellion*

Why do you think it is important that we live according to our beliefs as members of the Church of Jesus Christ?

Review the introduction to this lesson. Then read Doctrine and Covenants 63:1–2, 6, looking for what the Lord told the wicked and the rebellious.

Why do you think it is important that Church members open their hearts and listen to the Lord’s words?

Notice the phrase “let the unbelieving hold their lips” (D&C 63:6). At this time, some Church members had stopped believing in the truthfulness of the Church and were publicly speaking out against Joseph Smith and other Church leaders. One of the most vocal critics of the Church was a man named Ezra Booth.

Before joining the Church, Ezra Booth was a Methodist minister. He became interested in the Restoration in early 1831 after reading from the Book of Mormon. He traveled to Kirtland with John and Alice Johnson to meet the Prophet. Mrs. Johnson suffered from rheumatism, which had caused pain, swelling, and stiffness in her arm. When she first met Joseph Smith, she had not been able to raise her hand to her head for about two years.

“During the interview the conversation turned on the subject of supernatural gifts, such as were conferred in the days of the apostles. Some one said, ‘Here is

Mrs. Johnson with a lame arm; has God given any power to man now on the earth to cure her?’ A few moments later, when the conversation had turned in another direction, [Joseph] Smith rose, and walking across the room, taking Mrs. Johnson by the hand, said in the most solemn and impressive manner: ‘Woman, in the name of the Lord Jesus Christ I command thee to be whole,’ and immediately left the room. . . . Mrs. Johnson at once lifted [her arm] up with ease, and on her return home the next day she was able to do her washing without difficulty or pain” (from *Haydn’s History of the Disciples*, quoted in *History of the Church*, 1:215–16).



Think about how you might feel if you witnessed a miracle like this.

Soon after Ezra Booth witnessed this miracle, he was baptized.

Read Doctrine and Covenants 63:7–9, and identify what the Lord taught about signs and faith. Then complete the following principle: **Faith does not come by** \_\_\_\_\_.

After Ezra Booth was baptized, he received the priesthood and was sent on a mission to Missouri. He apparently began this mission with great expectations, assuming he would be able to convert many people by displaying signs and performing miracles. However, after preaching for a short time and not seeing the results he anticipated, Ezra Booth “turned away” and apostatized (Joseph Smith, in *History of the Church*, 1:216). The Prophet Joseph Smith made the following observation about Ezra Booth: “When he actually learned that faith, humility, patience, and tribulation go before blessing, and that God brings low before He exalts; that instead of the ‘Savior’s granting him power to smite men and make them believe,’ . . . then he was disappointed” (in *History of the Church*, 1:216).

Read Doctrine and Covenants 63:10–12, looking for additional principles about signs and faith. You may want to mark words or phrases in verse 10 that teach the following principle: **Signs come by faith, according to the will of God.**

 **1.** In your scripture study journal, explain why you think we receive signs *after* we have exercised faith. List one or two examples from the scriptures of people who witnessed great signs or miracles but did not demonstrate lasting faith or righteousness. (If you need help, see 1 Nephi 17:43–45.)

It is helpful to remember that signs and wonders are not always outwardly spectacular. Often we may receive a sign or a witness of the truthfulness of the gospel in a quiet, personal way as we exercise faith. We can exercise faith by praying, studying the scriptures, fasting, giving service, and living the principles of the gospel.



 **2.** In your scripture study journal, write how exercising faith has helped you or someone you know receive a witness of the truthfulness of the gospel.

As mentioned above, in addition to seeking signs, some Church members had also “turned away from [the] commandments” (D&C 63:13) and were committing serious sins. Read Doctrine and Covenants 63:14–19, and identify some of the sins they had committed. It may help you to understand verse 17 if you understand the following: A whoremonger is a person who participates in sexual sin. A sorcerer is someone who participates in activities that invite the influence of evil spirits. The phrase “lake which burneth with fire and brimstone” is used as a metaphor for the state of severe misery awaiting the wicked after they die (see Mosiah 3:27). This is also to what “the second death” in Doctrine and Covenants 63:17 is referring (see also Guide to the Scriptures, “Death, Spiritual,” scriptures.lds.org).

You may want to mark words in Doctrine and Covenants 63:16 that teach the following principle: **If we look upon others with lust, we will not have the Spirit, but we will deny the faith.** Lusting includes looking at pornography.

## Doctrine and Covenants 63:22–66

### *The Lord promises blessings to the faithful in the last days*

In the revelation recorded in Doctrine and Covenants 63, the Lord spoke of the destruction that will come upon the wicked in the last days, but He also made powerful promises to the Saints.

As you learn about the destruction and promises the Lord spoke of, answer the following statements by marking them true (T) or false (F) after reading the associated scripture references. You may want to mark in your scriptures important principles you learn as you complete this assignment.

- \_\_\_1. During the wars in the last days, wicked people will destroy one another. (See D&C 63:32–33.)
- \_\_\_2. The Saints will easily escape all of the judgments and destructions of the last days. (See D&C 63:34.)
- \_\_\_3. When Jesus Christ comes again, He will destroy any wicked people who are still on the earth. (See D&C 63:34.)
- \_\_\_4. Those who are faithful will eventually overcome all the challenges of this life. (See D&C 63:47–48.)
- \_\_\_5. Righteous people who die before the Second Coming will be resurrected when the Savior comes to the earth. (See D&C 63:49.)
- \_\_\_6. Righteous people who are living on the earth at the time of the Second Coming will never die. (See D&C 63:50–51.)

Statement 1 is true, and statement 2 is false. The following statement from the Prophet Joseph Smith explains why statement 2 is false: “It is a false idea that the Saints will escape all the judgments, whilst the wicked suffer; for all flesh is subject to suffer, and ‘the righteous shall hardly escape;’ still many of the Saints will escape, for the just shall live by faith; yet many of the righteous shall fall a prey to disease, to pestilence, etc., by reason of the weakness of the flesh, and yet be saved in the Kingdom of God” (in *History of the Church*, 4:11).

Statements 3–5 are true, and statement 6 is false.

Doctrine and Covenants 63:47 contains a promise from the Lord. Complete the following principle based on this verse: **If we are \_\_\_\_\_, then we will \_\_\_\_\_.**

In what ways can the Lord help you “overcome the world” in your daily life?

# Doctrine and Covenants 64:1–19

As the Prophet Joseph Smith explained, we will not be able to escape all of the difficulties that come in the world in this life. However, if we are righteous, we will “yet be saved in the Kingdom of God” (in *History of the Church*, 4:11). Study Doctrine and Covenants 63:49, looking for blessings received by those who faithfully overcome the world.

One way we can demonstrate our faithfulness is through the way we use the Lord’s name, as explained in Doctrine and Covenants 63:59–64. As you study these verses, look for words and phrases that teach the following principle: **The name of Jesus Christ is sacred and must be spoken with care.** You may want to mark in your scriptures the words and phrases that teach this principle.

 **3.** In your scripture study journal, list some situations when you might appropriately use the name of Jesus Christ. Then answer the following questions:

- a. Why do you think we use the Savior’s name when we pray and testify and perform priesthood ordinances?
- b. When you use the Savior’s name, what can you do to remember that it is sacred and must be spoken with care?

This principle does not apply only to the name of the Savior. Think about some other words or subjects that “come from above” and are sacred. Then think about how you can make sure you speak about them “with care.”



Elder Dallin H. Oaks of the Quorum of the Twelve Apostles taught that the principle you have learned about the name of Jesus Christ also applies to the name of Heavenly Father: “There are no more sacred or significant words in all of our language than the names of God the Father and his Son, Jesus Christ” (“Reverent and Clean,” *Ensign*, May 1986, 50).

 **4.** Write the following at the bottom of today’s assignments in your scripture study journal:

*I have studied Doctrine and Covenants 63 and completed this lesson on (date).*

*Additional questions, thoughts, and insights I would like to share with my teacher:*

## Introduction

In September 1831, the Prophet Joseph Smith and a number of elders had recently returned to Ohio from their journey to dedicate the land and the temple site in Zion, or Independence, Missouri. During this journey the elders had experienced some disagreements and bad feelings, but most were able to reconcile with each other. On September 11, the Prophet received the revelation recorded in Doctrine and Covenants 64.

## Doctrine and Covenants 64:1–7

*The Lord assures the elders of His willingness to forgive*

Think about a time when you were hurt by the words or actions of another person and how you responded in that situation.

The Prophet Joseph Smith received the revelation recorded in Doctrine and Covenants 64 about one month after he and a group of elders had returned to Ohio from Independence, Missouri. These elders and other Church members had experienced difficulties because of disagreements and hard feelings among themselves. In this revelation the Lord said, “There are those among you who have sinned” (D&C 64:3). The Lord’s words in this revelation teach us how to respond when others have hurt us.

Read Doctrine and Covenants 64:1–4, looking for phrases that describe how the Lord responded to those who had sinned. Write them in the following chart. (You may also want to mark them in your scriptures.)

D&C 64:2	D&C 64:3	D&C 64:4





**1. Doctrine and Covenants 64:1–4 teaches that the Lord is compassionate, forgiving, and merciful. In your scripture study journal, write why this principle about the Savior is important to you.**

At the time this revelation was received, some Church members, including some of the elders who had been traveling with Joseph Smith, had become critical of the Prophet. In Doctrine and Covenants 64:6, the Lord referred to the criticism of the Prophet by using the phrase “sought occasion against him.” Read Doctrine and Covenants 64:5–6, looking for what the Lord taught.

Ponder the following questions:

- What did the Lord say about Joseph Smith?
- What can we learn from these verses?

The Lord also explained some conditions of forgiveness. According to Doctrine and Covenants 64:7, what must we do to receive the Lord’s forgiveness?

---



---

## Doctrine and Covenants 64:8–19

*The Lord commands His servants to forgive one another*

In addition to feeling physical pain, what emotions do you think you would feel if you were bitten or stung by a venomous animal? Rattlesnakes are venomous snakes common in the Americas. Rattlesnake bites cause pain, swelling, numbness, and discoloration. If they are untreated, they can lead to permanent tissue damage or even death.

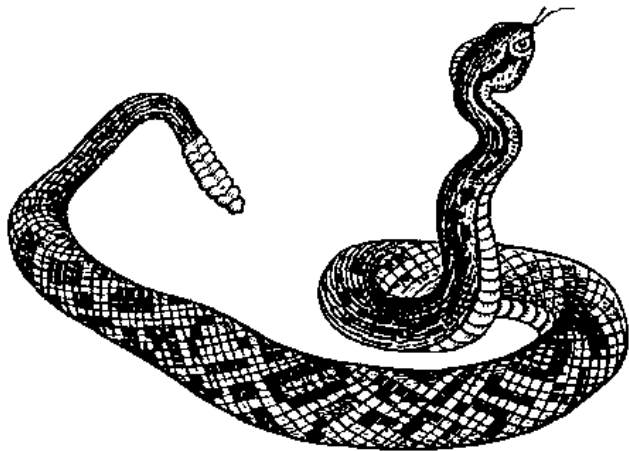

Elder Marion D. Hanks of the Seventy spoke about the choices a person faces if they have been bitten by a rattlesnake: “There are two courses of action to follow when one is bitten by a rattlesnake. One may, in anger,

fear, or vengefulness, pursue the creature and kill it. Or he may make full haste to get the venom out of his system” (“Forgiveness: The Ultimate Form of Love,” *Ensign*, Jan. 1974, 21).

Which of these two courses of action do you think is wiser? Why?

Elder Hanks said, “If we pursue the [second] course we will likely survive, but if we attempt to follow the [first], we may not be around long enough to finish it” (“Forgiveness,” 21).

A person’s choices after receiving a rattlesnake bite can be compared to our choices when we feel hurt because of the words or actions of another person. Read Doctrine and Covenants 64:8, looking for the consequences some of the Lord’s disciples faced because they refused to forgive one another.



**2. Answer the following questions in your scripture study journal:**

- How can a person be afflicted (or hurt) by not forgiving others?
- How is this like the consequences of a person chasing a rattlesnake that has bitten him or her?

Study Doctrine and Covenants 64:9, looking for another consequence of not forgiving others.

We learn from Doctrine and Covenants 64:9 that **if we do not forgive others, we stand condemned before the Lord.**

The lesson that may be most helpful to us to learn from this passage is to be forgiving. We receive great peace in our lives when we forgive others. As you read the following statement by Elder David E. Sorensen of the Seventy, think about how it relates to this truth: “It can be very difficult to forgive someone the harm they’ve done us, but when we do, we open ourselves up to a better future. No longer does someone else’s wrongdoing control our course. When we forgive others, it frees us to choose how we will live our own lives. Forgiveness means that problems of the past no longer dictate our destinies, and we can focus on the future with God’s love in our hearts” (“Forgiveness Will Change Bitterness to Love,” *Ensign* or *Liahona*, May 2003, 12).

Carefully study Doctrine and Covenants 64:10–11, and identify further principles the Lord taught about forgiveness.



**3.** In your scripture study journal, explain how the principles you learned from Doctrine and Covenants 64:10–11 could help a person in the following situations:

- a. A young woman is hurt and embarrassed after learning that some of her peers have been spreading gossip about her. Later, some of these people apologize, but others do not. The young woman forgives those who apologized but holds a grudge against the others.
- b. A young man disobeys a commandment. He prays for forgiveness and discusses the problem with his bishop. However, even after the bishop has assured the young man that he has fully repented, the young man continues to feel unworthy because of this past sin.
- c. A young woman is feeling sad and confused because of the actions of her father. He has abandoned his family. Before he left, he rarely showed love for the family and was often cruel. She does not understand why her father acted this way, and she carries feelings of anger toward him. She knows she should seek to forgive him, but she doesn't think that she can.



Consider if there is anyone whom you need to forgive. At times it can be extremely difficult to forgive another. As you read the following counsel from President Gordon B. Hinckley, look for what you can do if you are struggling to forgive someone: "If there be any who nurture in their hearts the poisonous brew of enmity toward another, I plead with you to ask the Lord for strength to forgive. . . . It may not be easy, and it may not come quickly. But if you will seek it with sincerity and cultivate it, it *will* come" ("Of You It Is Required to Forgive," *Ensign*, June 1991, 5).



**4.** Answer the following question in your scripture study journal: How do you think praying for strength can help you to forgive?

Study Doctrine and Covenants 64:12–14. Note that the Lord taught that our choice to forgive others does not relieve them of responsibility for their actions. They are still accountable to the Lord for the wrongs they have done.

Read Doctrine and Covenants 64:15–17, and notice that the Lord specifically said that He would forgive two of His servants, Isaac Morley and Edward Partridge, because they would repent of their sins.

At the beginning of this lesson, you learned that the Lord is compassionate, forgiving, and merciful. As you forgive, you can become more like Him. Decide how you can apply the principles of forgiveness you have learned today.



## Scripture Mastery—Doctrine and Covenants 64:9–11

Spend a few minutes reading Doctrine and Covenants 64:9–11 out loud. Once you have repeated the scripture passage at least five times, find a sibling, parent, or friend who will help you practice memorizing it. Recite the scripture passage to this person until you can repeat it from memory. Explain to the person how the principles in these verses can help you throughout your life. Then ask the person to sign today's entry in your scripture study journal.



**5.** Write the following at the bottom of today's assignments in your scripture study journal:

*I have studied Doctrine and Covenants 64:1–19 and completed this lesson on (date).*

*Additional questions, thoughts, and insights I would like to share with my teacher:*

### UNIT 14: DAY 4

# Doctrine and Covenants 64:20–43

## Introduction

The Prophet Joseph Smith received the revelation recorded in Doctrine and Covenants 64 on September 11, 1831. About two weeks before he received this revelation, the Prophet had returned to Ohio after overseeing the dedication of the land and the temple site of Zion in Independence, Missouri. Doctrine and Covenants 64:20–43 contains the Lord's teachings about the sacrifices He required of the Saints and about the establishment of Zion in the latter days.

## Doctrine and Covenants 64:20–25

### *The Lord teaches that He requires our hearts*

On the following lines, write about a time when you felt you sacrificed to follow the Lord's commandments (such as refraining from participating in a sporting event or a similar activity in order to keep the Sabbath day holy): \_\_\_\_\_

\_\_\_\_\_

\_\_\_\_\_

Think about how you may have been blessed for making this sacrifice. You can learn more about sacrifices the Lord requires of us as you study Doctrine and Covenants 64:20–43 and read the Lord’s commandments to Isaac Morley, Frederick G. Williams, and other early Church members.



Isaac Morley farm, Kirtland, Ohio

Isaac Morley owned a large farm in Kirtland, Ohio. He generously invited many Church members, including Joseph Smith and his family, to live on the property.

Read Doctrine and Covenants 64:20, looking for what the Lord instructed Isaac Morley to do with his farm. In the appropriate space in following chart, write what the Lord told Isaac Morley to do.

	Isaac Morley (D&C 64:20)	Frederick G. Williams (D&C 64:21)
What did the Lord say he should do?		
How did he react to the Lord’s instruction? (See information below.)		
What was the result of obeying the Lord’s instruction? (See information below.)		

This was a great sacrifice for Isaac Morley. Most of the money from the sale of the farm was to be used to buy land for other Church members in Independence, Missouri.

Study Doctrine and Covenants 64:20, looking for the blessing the Lord promised to give Isaac Morley if Isaac sold his farm. From this verse we learn that **if we follow the Lord’s will for us, we will not be tempted above that which we can bear.**

Isaac Morley followed the Lord’s commandment to sell his farm and was blessed to be able to withstand temptation. He was one of the first Saints to settle in Independence, Missouri, where he sought to establish Zion. He served the Lord faithfully throughout his life. In the chart, write Isaac’s reaction and the result of his action.



**1.** In your scripture study journal, list two or three commandments the Lord has given to all of us (such as the commandment to pray always). Then explain how obeying these commandments can help you avoid temptation.

Another man, Frederick G. Williams, also owned a farm in Kirtland. His farm consisted of two houses, a large barn, and many acres of land. Read Doctrine and Covenants 64:21, looking for the commandment the Lord gave Frederick G. Williams.

In the chart above, write what the Lord commanded Frederick G. Williams to do with his farm.

Although Frederick G. Williams was not asked to sell his farm like Isaac Morley, he still demonstrated a willingness to sacrifice. He told the Prophet Joseph Smith that his farm could be used to house Church members in need, including the Prophet’s parents. In addition, Brother Williams allowed the crops and animals raised on his farm to be used to feed and support the Saints. Later, he consecrated his entire farm to the Church without receiving any payment in return. Through the sacrifices of Frederick G. Williams and other faithful Saints in Ohio, the Lord retained “a strong hold in the land of Kirtland, for the space of five years” (D&C 64:21). During these years, the Saints built the Kirtland Temple. They dedicated the temple in 1836, five years after the revelation in Doctrine and Covenants 64 was given.

In the chart, complete the column for Frederick G. Williams by writing in the appropriate places what he did and the result of this action.

From the examples of Isaac Morley and Frederick G. Williams, we learn the following principle: **We are blessed as we obey the Lord and offer the sacrifices He asks of us.** You may want to write this principle in your scriptures.

The sacrifices Isaac Morley and Frederick G. Williams made regarding their farms illustrate another sacrifice the Lord required of them and that He requires of us today. Read Doctrine and Covenants 64:22, looking for the sacrifice the Lord requires of us.

You may want to mark the following principle in verse 22: **The Lord requires our hearts.**

 **2.** Answer the following questions in your scripture study journal:

- a. What do you think it means that the Lord requires our hearts?
- b. How can you show the Lord that you are willing to give your heart to Him?

Read Doctrine and Covenants 64:23–25, and identify a commandment we can keep to show that we have given our hearts to the Lord.

During this time in Church history, the term “tithing” referred to all free-will offerings or contributions to the Church. In 1838, tithing was defined as one-tenth of a person’s increase (see D&C 119 heading). Since that time, all members were expected to pay 10 percent of their increase annually.

 **3.** Answer the following questions in your scripture study journal:

- a. How can paying tithing show that we have given our hearts to the Lord?
- b. What are the blessings of paying a full and honest tithe?

Review Doctrine and Covenants 64:23, looking for the promise the Lord gives to those who pay tithing.

While the blessing specified in verse 23 applies to the future, the Lord also blesses us now for paying tithing. Think about experiences you have had when you or your family have been blessed as a result of paying tithing.

## Doctrine and Covenants 64:26–43

*The Lord gives instructions for the establishment of Zion*

Think of a time when you were told to complete a task that was difficult or felt overwhelming.

In August 1831, the Lord gave the Saints the enormous task of obtaining the money to purchase all of the land required to build the city of Zion in Jackson County, Missouri. The Saints knew that once they had purchased the land, they would have to work hard to build the city and the temple there.



Doctrine and Covenants 64:26–29 contains the Lord’s command to two of His servants, Newel K. Whitney and Sidney Gilbert, to use their store in Kirtland, Ohio, to help provide for the needs of the Saints. This is one example of a way some of the Saints were asked to sacrifice and contribute to the building of Zion.

Read Doctrine and Covenants 64:30–33, looking for phrases that might have encouraged the Saints who were seeking to accomplish the enormous task of building Zion.

Based on what you learned from reading these verses, complete the following principle:

**If we \_\_\_\_\_, then we can accomplish great things.**

After the Lord encouraged the Saints to be diligent in doing good things, He spoke again of obedience. Have you ever obeyed a parent, Church leader, teacher, or coach, but did so with a poor attitude? Notice in Doctrine and Covenants 64:34 the words that describe the attitude we should have as we obey the Lord.

You may want to write the following principle in your scriptures next to verse 34: ***We are to obey the Lord with our hearts and willing minds.***

 **4.** Answer the following questions in your scripture study journal:

- a. What do you think it means to obey the Lord with “the heart and a willing mind”?
- b. Think of a time when you obeyed the Lord with your heart and a willing mind. How was this different from times when you may not have obeyed so willingly?



Read Doctrine and Covenants 64:41–43, looking for information about the establishment of Zion in our day. It is important to remember that in the last days Zion will not only exist in one geographic location, such as Independence, Missouri. Zion will be established in all nations where people obey the Lord with their hearts and willing minds.

 **5.** In your scripture study journal, write down a goal of one thing you will do to obey the Lord with more heartfelt and willing obedience. As you work on this goal notice the difference this type of obedience makes in your life.

 **6.** Write the following at the bottom of today's assignments in your scripture study journal:

*I have studied Doctrine and Covenants 64:20–43 and completed this lesson on (date).*

*Additional questions, thoughts, or insights I would like to share with my teacher:*

## UNIT 15: DAY 1

# Doctrine and Covenants 65–66

### Introduction

On September 12, 1831, Joseph Smith and his family moved from Kirtland, Ohio, to Hiram, Ohio, about 30 miles southeast of Kirtland. They did this in response to counsel from the Lord (see D&C 63:65). The Prophet and his family moved in with the family of John and Alice Johnson, recent converts to the Church. A major reason for moving from Kirtland was to resume work on the inspired translation of the Bible (often referred to as the Joseph Smith Translation, or JST). Once in Hiram, Joseph recommenced that work. On October 30, 1831, the Prophet Joseph Smith received the revelation recorded in Doctrine and Covenants 65. In this revelation the Lord teaches that the gospel will be spread throughout the earth in preparation for His Second Coming and that the Saints are to pray for the growth of the kingdom of God.

William E. McLellin was baptized on August 20, 1831. Soon after that he was ordained an elder, and he accompanied Hyrum Smith for a few weeks as a missionary. In October he traveled to Ohio for a

conference of the Church. While there, he met the Prophet Joseph Smith. Through the Prophet the Lord gave William instructions and warnings to help him stay faithful and eventually receive eternal life. This revelation is recorded in Doctrine and Covenants 66.

## Doctrine and Covenants 65

*The Lord declares that the gospel will fill the earth*

 **1.** In your scripture study journal, list some things you regularly pray for.

Doctrine and Covenants 65 is a revelation on prayer. As you study this revelation, you will find counsel from the Lord about something we should pray for—particularly as we witness the fulfillment of events prophesied to occur in the latter days.

Read Doctrine and Covenants 65:1–2, looking for how the Lord described the spreading of the gospel. You may want to mark where the Lord said the gospel of Jesus Christ will go.

Notice that the Lord said that “the keys of the kingdom of God are committed unto man on the earth” (D&C 65:2). The phrase “keys of the kingdom” refers to the priesthood authority to preside and to authorize the administration and performance of priesthood ordinances in the Church. With these priesthood keys, the President of the Church leads our efforts to preach the gospel.



What do you know about Daniel's interpretation of King Nebuchadnezzar's dream, recorded in Daniel 2 in the Old Testament?

You may recall that King Nebuchadnezzar had been troubled by a dream and that the Lord revealed the dream and its meaning to the prophet Daniel. In the dream a great image, which represented various political kingdoms, was destroyed by a stone cut without hands from a mountain. The stone started small but grew until it filled the whole earth. (See Daniel 2:31–45.)

In Doctrine and Covenants 65:2, the phrase “kingdom of God” refers to the kingdom of God on the earth—The Church of Jesus Christ of Latter-day Saints (see Doctrine and Covenants 65:5–6). You may want to write this in your scriptures near verse 2.

Read the following statement from President Gordon B. Hinckley, looking for what he said about the kingdom of God:

“We are citizens in the greatest kingdom on earth—a kingdom not directed by the wisdom of men but led by the Lord Jesus Christ. Its presence is real. Its destiny is certain. This is the kingdom of which the prophet Daniel spoke—a stone, as it were, that should be cut out of the mountain without hands and roll forth and fill the earth. (See Dan. 2:34–35.)

“No mortal man created this kingdom. It came through revelation from its divine head. And since the nineteenth-century days of its inception, it has gone forth like a rolling snowball gathering mass” (“Pillars of Truth,” *Ensign*, Jan. 1994, 4).



**2.** Answer the following questions in your scripture study journal:

- In what ways do you see that Daniel’s prophecy is being fulfilled today? How does this strengthen your testimony of The Church of Jesus Christ of Latter-day Saints?
- What does it mean to you to be part of the kingdom of God on the earth?



Read the following statement from Elder Neil L. Andersen of the Quorum of the Twelve Apostles, and think about how you might complete the final sentence:

“Have you ever thought about why you were sent to earth at this specific time? You were not born during the time of Adam and Eve or while pharaohs ruled Egypt or during the Ming dynasty. You have come to earth at this time, 20 centuries after the first coming of Christ. The priesthood of God has been restored to the earth, and the Lord has set His hand to prepare the world for His glorious return. These are days of great opportunity and important responsibilities. These are your days.

“With your baptism, you declared your faith in Jesus Christ. . . . One of your important responsibilities is to . . .” (“Preparing the World for the Second Coming,” *Ensign* or *Liahona*, May 2011, 49).

Read Doctrine and Covenants 65:3–4, looking for responsibilities you have as a member of the kingdom of God on the earth.

In verse 3, the phrase “prepare ye the supper of the Lamb” refers to our responsibility to prepare the world for the Second Coming of Jesus Christ. You may want to write the following principle in your scriptures next to Doctrine and Covenants 65:3–4: **We have a responsibility to prepare ourselves and others for the Second Coming of the Lord Jesus Christ.**

Elder Andersen testified of this truth. He completed the final sentence in the statement above with these words: “One of your important responsibilities is to help prepare the world for the Second Coming of the Savior” (“Preparing the World for the Second Coming,” 49).



**3.** Answer the following questions in your scripture study journal:

- As you think about your responsibility to prepare yourself and others for the Second Coming of Jesus Christ, what thoughts and feelings do you have?
- Notice in Doctrine and Covenants 65:4 that we are to “make known [the Lord’s] wonderful works among the people.” What are some ways you can do this?

Read Doctrine and Covenants 65:5–6, and mark at least three things we should pray for.

How might praying for these things help you prepare yourself and others for the Second Coming?

Read the following statement by President Thomas S. Monson. Look for something President Monson asked us to continually pray for, and think about how such prayers can help prepare the world for the Second Coming of Jesus Christ.

“I would ask that your faith and prayers continue to be offered in behalf of those areas where our influence is limited and where we are not allowed to share the gospel freely at this time. Miracles can occur as we do so” (“Welcome to Conference,” *Ensign* or *Liahona*, Nov. 2009, 6).



**4.** From what you have learned in Doctrine and Covenants 65, write about one thing you will do to help prepare yourself and others for the Second Coming of Jesus Christ.

## Doctrine and Covenants 66

*The Lord counsels William E. McLellin to continue faithful to the end*

William E. McLellin had prayed in secret, asking that the Lord would reveal answers to five specific questions through the Prophet Joseph Smith. Without revealing the questions, William requested a revelation. On October 29, 1831, as the Prophet Joseph dictated the revelation found in Doctrine and Covenants 66, William found that each of his questions was answered.

Although William E. McLellin did not remain faithful, writing 10 years after he had left the Church, he could not deny that the Prophet Joseph Smith had been inspired. He recorded the following regarding this revelation: “I now testify in the fear of God, that every question which I had thus lodged in the ears of the Lord of Sabaoth, were answered to my full and entire satisfaction. I desired it for a testimony of Joseph’s inspiration. And I to this day consider it to me an evidence which I cannot refute” (in Jan Shipps and John W. Welch, eds., *The Journals of William E. McLellin, 1831–1836* [1994], 57).

### Inserting Your Name in the Scriptures

To make a scriptural teaching more personal, consider inserting your own name in a verse of scripture. For example, you could insert your name at the beginning of Doctrine and Covenants 66:12, imagining that the Lord is speaking directly to you.

As you study Doctrine and Covenants 66, look for encouraging promises the Lord gave to William E. McLellin. Also look for words of correction and warning.



5. In your scripture study journal, write one of the promises and one of the warnings the Lord gave to Brother McLellin, including the verse numbers where they are found. Then write a

sentence or two, explaining what the promise and the warning teach you about the Lord.



6. Write the following at the bottom of today’s assignments in your scripture study journal:

*I have studied Doctrine and Covenants 65–66 and completed this lesson on (date).*

*Additional questions, thoughts, and insights I would like to share with my teacher:*

## UNIT 15: DAY 2

# Doctrine and Covenants 67

## Introduction

In November 1831, a group of elders gathered for a special conference in Hiram, Ohio. One item of discussion at the conference was the publication of revelations the Prophet Joseph Smith had received. During this meeting the Lord gave a revelation to Joseph Smith and designated it as the preface to the book of revelations that would be published. That revelation is now the first section of the Doctrine and Covenants. Later in the conference, the Lord gave a revelation that is now recorded in Doctrine and Covenants 67. In that revelation the Lord spoke to brethren who had questions about the language of the revelations He had given to the Prophet.

## Doctrine and Covenants 67:1–3

*The Savior knows the minds and the hearts of men*

Have you ever wondered why some people receive a testimony of gospel principles and others do not?

In November of 1831, a group of elders, including the Prophet Joseph Smith, gathered to discuss the publication of the revelations the Prophet had received. Several of the elders had received a testimony that the revelations were true. However, others may have still been hoping to receive such a testimony.

Read Doctrine and Covenants 67:1–2, looking for what the Lord said about prayer.

From what you learn in verses 1–2, fill in the blanks in the following principle: **The Lord hears my**

\_\_\_\_\_ **and knows my** \_\_\_\_\_.



## Doctrine and Covenants 67:4–9

### *The Lord challenges those who criticize His revelations*

Have you ever wondered why we should follow Church leaders even though they are imperfect?

Read the section introduction for Doctrine and Covenants 67 and verse 5, looking for the different attitudes some elders had toward the revelations. (Remember that the first collection of the Prophet Joseph Smith’s revelations was titled the Book of Commandments. Later, the title was changed to the Doctrine and Covenants.) Note in the section introduction that “many of the brethren bore solemn testimony” of the truthfulness of the revelations. However, “some negative conversation was had concerning the language used in the revelations.” According to verse 5, some elders thought they could “express beyond [Joseph Smith’s] language.” Because of pride in their own intellect, they felt they were more qualified to write revelations than the Lord’s anointed prophet (see 2 Nephi 9:28–29).

Read Doctrine and Covenants 67:4, and also read verse 5 again. Look for how the Lord responded to the elders’ concerns about the language of the revelations.

Why do you think it was important for the elders to understand that the Lord knew He was working through imperfect servants?

Read Doctrine and Covenants 67:6–9, looking for the challenge the Lord gave to those who were concerned about the language of the revelations.

William E. McLellin decided to take the Lord’s challenge to write a revelation comparable to those the Prophet Joseph Smith had received. Joseph Smith recorded the following in his history: “William E. McLellin, as the wisest man, in his own estimation, having more learning than sense, endeavored to write a commandment like unto one of the least of the Lord’s, but failed; it was an awful responsibility to write in the name of the Lord. The Elders and all present that witnessed this vain attempt of a man to imitate the language of Jesus Christ, renewed their faith in the fullness of the Gospel, and in the truth of the commandments and revelations which the Lord had given to the Church through my instrumentality; and the Elders signified a willingness to bear testimony of their truth to all the world” (in *History of the Church*, 1:226).

 **1.** Answer the following question in your scripture study journal: How can knowing this principle help you improve your prayers? Then write about an experience that has helped you or someone you know gain a spiritual confirmation of gospel truths.

Read Doctrine and Covenants 67:3, looking for why some of the elders did not receive the blessing the Lord had offered them. You may want to mark the phrases that stand out to you.

 **2.** Answer the following question in your scripture study journal: How can allowing fear into your heart prevent you from receiving blessings? Then make a list of fears that might stop people from receiving blessings.

Ponder the Lord’s power to help us replace fear with faith. How can this knowledge help someone continue to develop a testimony?



After this event, all of the elders who were present agreed to sign a document giving formal testimony of the truthfulness of the revelations contained in the Book of Commandments.



**3.** Answer the following questions in your scripture study journal:

- a. Why do you think Joseph Smith, who had limited formal schooling, could produce these revelations, but William E. McLellin, who was well educated, could not?
- b. What can you learn from this account about judging our leaders because of their imperfections?

Ponder your commitment to follow your leaders in righteousness, regardless of the imperfections you or others may see in them.

## Doctrine and Covenants 67:10–14

*The Lord counsels His followers how to prepare to abide in God's presence*



**4.** In your scripture study journal, draw a chart with two columns. Label the first column *Reward* and the second column *How to Obtain the Reward*. Read Doctrine and Covenants 67:10–14, looking for the reward the Savior promised these brethren and the actions necessary for them to obtain that reward. Write your answers in the appropriate columns.

According to these verses, what did these brethren need to do to abide the presence of God? (The word *abide* means to endure or to remain in a certain place.) If they stripped themselves from jealousies and fears and humbled themselves, they would be able to abide the presence of God.



As recorded in Doctrine and Covenants 67:13, these brethren were encouraged to “continue in patience” until they were perfected. Read the following account, shared by President Dieter F. Uchtdorf of the First Presidency, which teaches about

the importance of patience in the process of becoming perfect:

“In the 1960s, a professor at Stanford University began a modest experiment testing the willpower of four-year-old children. He placed before them a large marshmallow and then told them they could eat it right away or, if they waited for 15 minutes, they could have two marshmallows.

“He then left the children alone and watched what happened behind a two-way mirror. Some of the children ate the marshmallow immediately; some

could wait only a few minutes before giving in to temptation. Only 30 percent were able to wait” (“Continue in Patience,” *Ensign* or *Liahona*, May 2010, 56).

How do you think this professor’s experiment and findings could apply to youth today?

President Uchtdorf then spoke about the findings from the marshmallow experiment:

“As time went on, [the professor] kept track of the children and began to notice an interesting correlation: the children who could not wait struggled later in life and had more behavioral problems, while those who waited tended to be more positive and better motivated, have higher grades and incomes, and have healthier relationships.

“What started as a simple experiment with children and marshmallows became a landmark study suggesting that the ability to wait—to be patient—was a key character trait that might predict later success in life. . . .

“Waiting can be hard. Children know it, and so do adults. We live in a world offering fast food, instant messaging, on-demand movies, and immediate answers to the most trivial or profound questions. We don’t like to wait. . . .

“Patience—the ability to put our desires on hold for a time—is a precious and rare virtue. We want what we want, and we want it now. Therefore, the very idea of patience may seem unpleasant and, at times, bitter.

“Nevertheless, without patience, we cannot please God; we cannot become perfect. Indeed, patience is a purifying process that refines understanding, deepens happiness, focuses action, and offers hope for peace” (“Continue in Patience,” 56).



**5.** Answer the following question in your scripture study journal: Why do you think patience is necessary in your efforts to be worthy and abide the presence of the Lord? Also, take a few minutes to ponder areas in your life in which you might need to have more patience with yourself or others. If you feel comfortable doing so, record a goal that includes being more patient in your efforts to become pure before God.



**6.** Write the following at the bottom of today’s assignments in your scripture study journal:

*I have studied Doctrine and Covenants 67 and completed this lesson on (date).*

*Additional questions, thoughts, and insights I would like to share with my teacher:*

# Doctrine and Covenants 68

## Introduction

On November 1, 1831, the Prophet Joseph Smith met with a group of elders in Hiram, Ohio, for a special conference. They discussed the publication of the Book of Commandments, a collection of the revelations the Prophet had received. Four of the elders at the conference asked Joseph Smith to inquire of the Lord about His will for them. In response to this request, the Prophet received a revelation that is now recorded in Doctrine and Covenants 68. The revelation includes counsel to those called to preach the gospel, instructions about the calling of bishops, and a commandment for parents to teach their children the principles and ordinances of the gospel.

## Doctrine and Covenants 68:1–12

*The Savior gives counsel to those who are called to preach the gospel*

Consider the following questions:

- What worries or concerns might someone have about serving a full-time mission?
- What are some reasons people sometimes feel nervous about sharing the gospel with their family members and friends?



During a conference on November 1, 1831, four elders who would be serving as missionaries approached the Prophet Joseph Smith and asked to know the Lord's will concerning them. In response, the Lord revealed a pattern for preaching the gospel.

Read Doctrine and Covenants 68:1–5, looking for a pattern for preaching the gospel. Consider marking what you find. (You will find the word *ensample* in verses 2 and 3. An *ensample* is a pattern or model.)

Which of the following is *not* part of the pattern for preaching the gospel as found in verse 1?

- Sing songs of everlasting love.
- Proclaim the gospel by the Spirit.
- Reason with those you teach.
- Expound the scriptures.

Read Doctrine and Covenants 68:6, looking for the additional encouragement the Lord gave to His servants.



1. Answer the following questions in your scripture study journal:

- What principles do you see in Doctrine and Covenants 68:6 that might bring comfort to a missionary?
- Why is it important for you to know that the Lord stands by His faithful missionaries?
- How might this promise help you in your efforts to share the gospel now?

You may want to write the following principle in your scriptures next to Doctrine and Covenants 68:4: ***When the Lord's servants are moved upon by the Holy Ghost, their words will lead people to salvation.***



While those who are ordained to preach the gospel can help us know the will of the Lord, only the President of the Church has the right to receive and declare the will of the Lord for the entire Church. Under his direction, members of the First Presidency and the Quorum of the Twelve Apostles also have the authority to declare God's will for us. Thus, the principle taught in verse 4 can apply each time a member of the First Presidency or Quorum of the Twelve Apostles speaks in general conference.

Read Doctrine and Covenants 68:3–5 again, and identify a promise the Lord gives to His ordained servants. Then complete the following statement: When the Lord’s servants speak as they are moved by the Holy Ghost, their words are \_\_\_\_\_.

 **2.** Answer the following question in your scripture study journal: What are some ways to invite the influence of the Holy Ghost as we share the gospel?

In Doctrine and Covenants 68:7–12, we read that the Lord called these four elders to preach the gospel and baptize those who would believe. We also read about the blessings that come to them and to those who believe their words.

### Doctrine and Covenants 68:13–24

*The Lord reveals the qualifications for the office of bishop*

Imagine that a friend of another faith asks, “How was your bishop chosen?” What would you say?

Read Doctrine and Covenants 68:14–15, 20, looking for how bishops are selected.

The phrase “literal descendant of Aaron” refers to descendants of Moses’s brother, Aaron, in the Old Testament. This descendant would have a right to the office of Presiding Bishop if called and approved by the First Presidency. In Moses’s day only descendants of the tribe of Levi held the Levitical or Aaronic priesthood. A person had to be a blood descendent of this line to be given the priesthood. The right to hold this priesthood went from father to son. At that time, if the father did not hold the priesthood, a son would not have that opportunity.

Write the following principle in your scriptures:  
***Bishops must be approved by the First Presidency and ordained by proper authority.***

In the early days of the Church, members of the First Presidency ordained and set apart all bishops. In the Church today, this is still true for the Presiding Bishop. However, the calling, ordaining, and setting apart of bishops is conducted by stake presidents under the direction of the First Presidency. A stake president, with support from his counselors in the stake presidency, seeks revelation to know when to call a new bishop and whom to call. He sends his recommendation to the First Presidency for approval. When the First Presidency approves this calling, they authorize the stake president to ordain and set apart the new bishop.

 **3.** Answer the following question in your scripture study journal: Why is it important to you to know that the First Presidency approved the calling of your bishop?

Before the Prophet Joseph Smith received the revelation recorded in Doctrine and Covenants 68, Edward Partridge was the only bishop in the Church. When other bishops were called, Bishop Partridge served as the Presiding Bishop. Today the Presiding Bishop is a General Authority and has responsibility over the temporal welfare of the entire Church (see D&C 107:68).

### Doctrine and Covenants 68:25–35

*The Lord commands parents to teach their children*

Do you ever think about the possibility of being married and having children in a few years?

List three things that you will want to teach your children: \_\_\_\_\_

\_\_\_\_\_



Read Doctrine and Covenants 68:25–27, and mark the doctrines the Lord commanded parents to teach their children. If these things are not on your list, consider adding them.

 **4.** In your scripture study journal, write about why you think parents are commanded to teach their children to understand the doctrine of repentance, faith in Christ, baptism, and the gift of the Holy Ghost. How have your parents helped you learn the gospel? Consider writing them a note of gratitude.

In Doctrine and Covenants 68:28–31, the Lord gave additional counsel to parents, as well as to the Saints in Zion.

 **5.** To help in your preparation to be a parent, complete two or more of the following activities. Answer the questions in your scripture study journal.



# Doctrine and Covenants 69–71

## Introduction

In late October or early November 1831, Oliver Cowdery received an assignment to carry the manuscript for the Book of Commandments from Ohio to Missouri. In Missouri, William W. Phelps would print the book at his press. On November 11, 1831, the Lord appointed John Whitmer to be Oliver's traveling companion and commanded him to continue in his duties as Church historian (see D&C 69). The next day, the Lord appointed six men to serve as stewards over the revelations (see D&C 70). In December 1831, the Lord commanded the Prophet Joseph Smith and Sidney Rigdon to serve a mission to dispel unfriendly feelings against the Church and to prepare the way for the revelations and commandments that were to be published (see D&C 71).

## Doctrine and Covenants 69

*The Lord reveals the importance of keeping histories*



Has anyone ever trusted you to take care of something valuable? What was it? How did that trust influence how you cared for the thing of value?

Read the section introduction to Doctrine and Covenants 69, and mark what Oliver Cowdery was entrusted with.

If these valuable items were entrusted to you, how would you care for them?

- a. Read Doctrine and Covenants 68:28, looking for what the Lord commands parents to teach their children.
  - Why do you think it would be important for you to teach your children to pray?
  - How were you taught to pray?
  - How has prayer blessed you and your family?
  - In your opinion, how does prayer help us “walk uprightly before the Lord”?
- b. Read Doctrine and Covenants 68:29, looking for what the Lord commands the inhabitants of Zion (Church members) to do.
  - What have you learned from your parents or others about keeping the Sabbath day holy?
  - What can you do to help your family keep the Sabbath day holy?
- c. Read Doctrine and Covenants 68:30, looking for what the Lord commands parents and children to do. (Note that the word *idler* refers to someone who is lazy or not engaged in productive activities.)
  - When have you seen the blessings that come from hard work?

Read the following information about idleness: “The Lord has commanded us not to be idle. Idleness can lead to inappropriate behavior, damaged relationships, and sin. One form of idleness is spending excessive amounts of time in activities that keep you from productive work, such as using the Internet, playing video games, and watching television” (*For the Strength of Youth* [booklet, 2011], 40).

  - How can idleness lead to wickedness?
  - What are some things that can help a person overcome a tendency to be idle?
- d. Read Doctrine and Covenants 68:31–32, looking for what the Lord commands parents and children to do.
  - How do you think greed can affect a family?
  - What can you do in your life to overcome selfishness and greed?



6. Answer the following questions in your scripture study journal:

- a. Why is it important to prepare now to be a good parent?
- b. What goal can you set that will help you prepare to be a good parent?



7. Write the following at the bottom of today's assignments in your scripture study journal:

*I have studied Doctrine and Covenants 68 and completed this lesson on (date).*

*Additional questions, thoughts, and insights I would like to share with my teacher:*



Read Doctrine and Covenants 69:1–2, and find the counsel the Lord gave in regard to these valuable items.

Why do you think it was wise to have more than one person care for these valuable items?

The Lord trusted John Whitmer with another important responsibility, in addition to helping Oliver Cowdery transport the revelations and money to Missouri. Read Doctrine and Covenants 69:3–8, looking for another duty the Lord assigned to John Whitmer. You may want to mark what you find.

Review what Doctrine and Covenants 47 teaches about John Whitmer’s appointment as Church historian and recorder.

 **1.** Answer the following questions in your scripture study journal:

- a. According to Doctrine and Covenants 70:8, why was it important for John Whitmer to keep a history of the Church?
- b. Why would these be good reasons for you to keep a personal history?

Consider writing the following principle in the margin of your scriptures: ***The Lord expects histories to be kept for the good of the Church and the rising generation.***

 **2.** Answer the following questions in your scripture study journal:

- a. In your opinion, how does keeping Church histories and personal histories benefit the Church?
- b. How might they benefit the rising generation?

 **3.** Do one or both of the following activities, and then write a summary of your experience in your scripture study journal:

- a. Think about an account from either Church history or your family history that has helped you in some way. Share this story with a family member or friend.
- b. Ask a family member to tell you a family history story that has benefitted him or her.

## Doctrine and Covenants 70:1–4

*The Savior appoints stewards to care for His revelations*

The Prophet Joseph Smith also recorded a personal history. Read the section introduction for Doctrine and Covenants 70, and mark what Joseph Smith’s history says about the Doctrine and Covenants.



 **4.** Answer the following questions in your scripture study journal:

- a. What are some ways the Doctrine and Covenants is a benefit to the world?
- b. How has the Doctrine and Covenants benefitted you?

Read Doctrine and Covenants 70:1, and identify the six names mentioned. Then read Doctrine and Covenants 70:2–4, looking for the responsibility that the Lord gave these six men.

What do you think the phrase “an account of this stewardship will I require of them” (D&C 70:4) means? While the responsibilities that the Lord gives to us may not be the same type of stewardships as these men, what does this principle suggest about what the Lord will require of us at the day of judgment?

From what you have learned in these verses, fill in the blank to complete the following principle: **The Lord will hold us \_\_\_\_\_ for the duties He has entrusted to us.**

 **5.** Answer the following questions in your scripture study journal:

- a. How might this principle influence the way we respond to Church callings and assignments?
- b. What are some of your responsibilities that the Lord will hold you accountable for?

## Doctrine and Covenants 70:5–18

*The Lord explains how to meet the temporal needs of those in full-time Church service*

Doctrine and Covenants 70:5–18 teaches that the men entrusted to be stewards over the revelations and commandments were to make the printing and distribution of Church publications their employment. In our day, General Authorities of the Church give up

their livelihoods to serve full-time, so they receive a modest living allowance—enough for them to support themselves and their families.

Why is it appropriate for Church leaders who are called to full-time service to receive compensation for their needs?

## Doctrine and Covenants 71

*The Lord teaches the Prophet Joseph Smith and Sidney Rigdon how to respond to critics of the Church*

Have you ever heard criticisms about the Church? What are appropriate ways to respond to criticism of the Church?

To help you understand the background of the revelation recorded in Doctrine and Covenants 71, read the following paragraph. As you read, look for how the Church and its leaders were being criticized at the time this revelation was given.

Ezra Booth was a former Methodist minister who joined the Church after witnessing a healing. He traveled as a missionary to Missouri, but he was disappointed when he couldn't perform miracles to convince others of the truth. In addition, Brother Booth did not believe that Joseph Smith's conduct was appropriate for a prophet or a spiritual leader. He became highly critical of the Prophet Joseph Smith, left the Church, and wrote nine letters criticizing the Church and its leaders. These letters, published in a newspaper called the *Ohio Star*, led some people to develop unfriendly feelings toward the Church and its leaders. The Prophet Joseph Smith recorded that Ezra Booth's writings were "a series of letters, which, by their coloring, falsity, and vain calculations to overthrow the work of the Lord, exposed [Ezra Booth's] weakness, wickedness and folly, and left him a monument of his own shame, for the world to wonder at" (in *History of the Church*, 1:216–17).

Symonds Ryder, another disaffected Church member, gave copies of some of the revelations to another newspaper, attempting to discourage people from joining the Church. The agitation caused by Ezra Booth and Symonds Ryder grew into a serious problem.

Read Doctrine and Covenants 71:1–4, looking for what the Lord told the Prophet Joseph Smith and Sidney Rigdon to do to calm the unfriendly feelings that resulted from the newspaper articles.

Notice in verse 1 the manner in which Joseph and Sidney were to proclaim the gospel. What principle can we learn from this instruction about how to respond to criticism of the Church?



6. Answer the following question in your scripture study journal: What can you do now to prepare to respond to criticism against the Church or its leaders?

You may want to write the following principle in the margin of your scriptures next to Doctrine and Covenants 71:1: ***When people criticize the Church, we can respond by sharing truths from the scriptures and following the guidance of the Spirit.***



Elder Robert D. Hales of the Quorum of the Twelve Apostles explained how the Spirit can help us respond to criticisms against the Church: "As we respond to others, each circumstance will be different. Fortunately, the Lord knows the hearts of our accusers and how we can most effectively respond to them. *As true disciples seek guidance from the Spirit, they receive inspiration tailored to each encounter. And in every encounter, true disciples respond in ways that invite the Spirit of the Lord*" ("Christian Courage: The Price of Discipleship," *Ensign* or *Liahona*, Nov. 2008, 73).

Read Doctrine and Covenants 71:5–11, looking for counsel and comfort the Lord gave to the Prophet Joseph Smith and Sidney Rigdon as they responded to criticism against the Church. Also look for the promises the Lord gave them in verses 7 and 10.

Note that this revelation directed two Church leaders—the Prophet Joseph Smith and Sidney Rigdon—to meet with those who were attacking the Church in public and in private and to seek to confound those people in the lies they were spreading. Generally, this is the responsibility of Church leaders, unless priesthood leaders direct or assign others to do so. However, youth of the Church should be prepared to respond to falsehoods about the Church in the manner described by Elder Hales above.

### Practice Explaining Gospel Truths

Throughout your life you will have opportunities to explain your beliefs and the teachings of the gospel—as a missionary, in Church callings, or to your family, friends, and acquaintances. As you practice explaining the gospel in writing, it may be helpful to imagine you are writing to a specific person. Writing with a specific person in mind can help you focus on applying the message of the gospel to the needs of that person. What have you learned about the doctrine of repentance that you could teach to a friend or family member?

Elder Hales also gave counsel concerning our attitude toward those who criticize the Church or its leaders: *“As true disciples, our primary concern must be others’ welfare, not personal vindication.* Questions and criticisms give us an opportunity to reach out to others and demonstrate that they matter to our Heavenly Father and to us. Our aim should be to help them understand the truth, not defend our egos or score points in a theological debate. Our heartfelt testimonies are the most powerful answer we can give our accusers. And such testimonies can only be borne in love and meekness” (“Christian Courage,” 73–74).

Sidney Rigdon obeyed the Lord’s counsel and invited Ezra Booth to join him in the town of Ravenna, Ohio, where they would publicly discuss the letters Ezra had sent to the newspaper. Sidney also challenged Symonds Ryder to a public debate on the Book of Mormon. Both men declined the invitations. Sidney still testified of the truth in Ravenna and other locations.



**7.** Answer the following questions in your scripture study journal:

- a. How might the teachings in Doctrine and Covenants 71:8–9 be comforting to those who respond to criticism against the Church?
- b. According to verse 10, why shouldn’t we be overly concerned when people are critical of the Church?

Consider what you will do to better prepare yourself to respond to criticism against the Church.



**8.** Write the following at the bottom of today’s assignments in your scripture study journal:

*I have studied Doctrine and Covenants 69–71 and completed this lesson on (date).*

*Additional questions, thoughts, and insights I would like to share with my teacher:*

## UNIT 16: DAY 1

# Doctrine and Covenants 72–74

## Introduction

On December 4, 1831, the Prophet Joseph Smith received the revelation found in Doctrine and Covenants 72, wherein the Lord called a new bishop in Ohio and revealed some of his duties. In Doctrine and Covenants 73, given in January 1832, the Lord directed Joseph Smith and Sidney Rigdon to recommence their work on the translation of the Bible. As a result of their work on the translation, the Lord gave the revelation in Doctrine and Covenants 74, which is an explanation of 1 Corinthians 7:14.

## Doctrine and Covenants 72:1–8

*The Lord calls Newel K. Whitney as bishop in Ohio*

Have you ever received a calling or been asked to do something difficult in the Church and felt overwhelmed or incapable of doing it? Read Doctrine and Covenants 72:1–2, looking for the calling that needed to be made in Ohio (“this part of the Lord’s vineyard”).

In the summer of 1831, Bishop Edward Partridge, the first bishop called in the Church, moved nearly 900 miles west from Kirtland, Ohio, to Independence, Missouri, to serve as the bishop in Zion. As a result, the Lord declared that a new bishop was needed in Ohio. Read Doctrine and Covenants 72:3–6, and identify phrases that explain why the Saints in Ohio, who were stewards living the law of consecration, needed a bishop. (You were introduced to the law of consecration in the “Unit 10: Day 3” lesson material for Doctrine and Covenants 42:30–42 in this study guide.)

Ponder how your bishop or branch president helps you be accountable for your responsibilities as a member of the Church today.

Read Doctrine and Covenants 72:7–8, and notice whom the Lord called as the new bishop in Ohio.



When Newel K. Whitney was called to be the bishop in Ohio, he felt he was inadequate to serve in such a position. The following information from his grandson Elder Orson F. Whitney of the Quorum of the Twelve Apostles helps us understand how Newel K. Whitney felt and what he learned about where his call had come from:

“The thought of assuming this important responsibility (the office of bishop) was almost more than he could bear. Though in natural gifts few men were better qualified for such a position, he nevertheless distrusted his ability, and [felt] incapable of discharging the high and holy trust. In his perplexity he appealed to the Prophet:

“‘I cannot see a bishop in myself, brother Joseph; but if you say it’s the Lord’s will, I’ll try.’

“‘You need not take my word alone;’ answered the Prophet, kindly, ‘Go and ask Father for yourself.’

“Newel . . . determined to do as [the Prophet] advised. His humble, heartfelt prayer was answered. In the silent of night and the solitude of his chamber, he heard a voice from heaven: *‘Thy strength is in me.’* The words were few and simple, but they had a world of meaning. His doubts were dispelled like dew before the dawn. He straightway sought the Prophet, told him he was

satisfied, and was willing to accept the office to which he had been called” (in B. H. Roberts, *A Comprehensive History of the Church*, 1:271).

 **1.** Respond to the following situation in your scripture study journal: Imagine that a friend or family member receives a calling to serve in the Church and feels overwhelmed and incapable of fulfilling the calling. Based on what you have learned in Doctrine and Covenants 72 and the experience Newel K. Whitney had concerning his calling, write a few sentences of counsel or testimony that you would give to help this person feel confident in accepting and fulfilling the calling.



President Henry B. Eyring of the First Presidency also taught about the source of callings to serve in the Church:

“To everyone, man or woman, girl or boy, who has been called or who will yet be, I give you my counsel. There are a few things you must come to know are true. . . .

“First, you are called of God. The Lord knows you. He knows whom He would have serve in every position in His Church. He chose you. . . . The person who was inspired to recommend you for this call didn’t do it because they liked you or because they needed someone to do a particular task. They prayed and felt an answer that you were the one to be called.

“The person who called you did not issue the call simply because he learned by interviewing you that you were worthy and willing to serve. He prayed to know the Lord’s will for you. It was prayer and revelation to those authorized of the Lord which brought you here” (“Rise to Your Call,” *Ensign*, Nov. 2002, 75–76).

 **2.** Answer the following question in your scripture study journal: How can understanding that **callings to serve in the Lord’s Church come from God** help you accept and diligently strive to fulfill your callings?

## Doctrine and Covenants 72:9–26

*The Lord explains the duties of a bishop*

 **3.** In your scripture study journal, list all of the duties and responsibilities of bishops and branch presidents that you can think of.

In Doctrine and Covenants 72:9–26, the Lord revealed some of Bishop Newel K. Whitney’s duties. The duties that the Lord gave were primarily related to Bishop Whitney’s role under the law of consecration. However, some of the bishops’ and branch presidents’ responsibilities in the Church today relate to these duties of the first bishops in the Church.



Read Doctrine and Covenants 72:10–12, looking for the duties the Lord gave Bishop Whitney. Circle any of the duties you listed in your scripture study journal that are similar to those described in these verses.

Some of the duties the Lord commanded Bishop Whitney to fulfill are similar to responsibilities required of bishops today. Read Doctrine and Covenants 72:16–18, looking for what Bishop Whitney was to give Church members who were moving to Missouri.

Saints moving to Missouri were to carry a certificate to Bishop Partridge, the bishop in Zion, verifying that they were worthy of an inheritance in Zion. In our day, temple recommends serve as a type of “certificate” that bishops and branch presidents give to Church members to certify their worthiness and allow them to enter the holy temples.

From this revelation concerning Bishop Whitney’s duties, we can learn that **bishops and branch presidents manage the temporal and spiritual affairs of the Church in their wards and branches.** (The word *temporal* refers to things pertaining to physical life, such as clothing, food, property, and money.)

Consider the ways that your life is blessed because the Lord has called your bishop or branch president to serve you and your family.

## Doctrine and Covenants 73

*The Lord directs Joseph Smith and Sidney Rigdon to continue the translation of the Bible*



Read the section introduction for Doctrine and Covenants 73, and look for what the Prophet Joseph Smith and Sidney Rigdon had been doing since the early part of December 1831.

Joseph Smith and Sidney Rigdon had been preaching to help combat misinformation about the Church resulting from the publication of Ezra Booth’s letters. In Doctrine and Covenants 73:1–2, the Lord revealed that the elders who had also been preaching were to continue doing so until the next conference. This conference would be held two weeks later.

Read Doctrine and Covenants 73:3–4, looking for what work the Lord commanded Joseph and Sidney to focus on at that time. This “work of translation” Joseph and Sidney were to again focus on was the inspired revision of the Bible. Many of the Prophet Joseph Smith’s inspired revisions are currently found in footnotes (JST) throughout the Bible and in a section in the Bible appendix (Joseph Smith Translation). The book of Moses and Joseph Smith—Matthew in the Pearl of Great Price are also from the inspired translation.

## Doctrine and Covenants 74

*The Lord explains the meaning of 1 Corinthians 7:14*

Imagine that you are serving as a full-time missionary of the Church. While speaking with a married couple who is investigating the Church, you learn that they had a son who died when he was only a few months old. The couple was told by their religious leader that the child was not able to be in heaven because he had not been baptized before he died. The parents feel intense sorrow because of the loss of their child and their belief that their baby has lost his salvation.

What would you say to these parents? (You will have the opportunity to write your response later in this lesson.)

Doctrine and Covenants 74 contains the Lord’s explanation of 1 Corinthians 7:14. Read Doctrine and Covenants 74:1, which is the Apostle Paul’s words from 1 Corinthians 7:14. The word *unbelieving* in verse 1 refers to Jews who had not accepted the gospel of Jesus Christ. Paul was not saying that a person could be saved by his or her spouse’s righteousness but that the conversion of one spouse could bring a sanctifying influence into the family. The phrase “else were your children unclean” in 1 Corinthians 7:14 has been used to justify the practice of infant baptism.

Read Doctrine and Covenants 74:2–6, looking for problems that had developed in the Apostle Paul’s day when one spouse in a marriage converted to the gospel

of Jesus Christ and the other spouse still practiced the law of Moses.

The Atonement of Jesus Christ fulfilled the law of Moses, and circumcision was no longer required. However, the Jews who followed the law of Moses believed a male child was unclean unless he was circumcised, which was usually done when the child was eight days old. In Doctrine and Covenants 74:2–6, the Lord explained how this false belief about the spiritual state of children and the practice of circumcision had caused problems in families in which one parent believed in the gospel of Jesus Christ and the other believed in the law of Moses. Similar conflicts in religious beliefs and practices may occur today in families in which one spouse is a member of the Church and the other spouse is not.

Read Doctrine and Covenants 74:7, and consider marking the doctrine the Lord taught about little children. Then read Moroni 8:8–12. Ponder how these verses apply to the missionary situation presented earlier. You may want to write *Moroni 8:8–12* as a cross-reference next to Doctrine and Covenants 74:7.

 **4.** In your scripture study journal, write what you would teach the married couple who believes their deceased baby is not able to be in heaven. How would you help them understand the doctrine taught in these verses that **little children are holy, being sanctified through the Atonement of Jesus Christ?**



Elder Shayne M. Bowen of the Quorum of the Seventy shared an experience he had as a young full-time missionary in Chile. Notice the effect that learning the true doctrine that little children are sanctified through the Atonement of

Jesus Christ had on the woman Elder Bowen and his companion were teaching.

“Sister Ramirez advanced rapidly through the lessons. She was anxious to learn all the doctrine that we taught. One evening as we were discussing infant baptism, we taught that little children are innocent and have no need for baptism. We invited her to read in the book of Moroni [Moroni 8:10–12]. . . .

“After reading this scripture, Sister Ramirez began sobbing. My companion and I were confused. I asked, ‘Sister Ramirez, have we said or done something that has offended you?’

“She said, ‘Oh, no, Elder, you haven’t done anything wrong. Six years ago I had a baby boy. He died before we could have him baptized. Our priest told us that because he had not been baptized, he would be in limbo

for all eternity. For six years I have carried that pain and guilt. After reading this scripture, I know by the power of the Holy Ghost that it is true. I have felt a great weight taken off of me, and these are tears of joy.’ . . .

“After she suffered almost unbearable grief and pain for six years, the true doctrine, revealed by a loving Father in Heaven through a living prophet, brought sweet peace to this tormented woman. Needless to say, Sister Ramirez and her children who were eight years and older were baptized” (“Because I Live, Ye Shall Live Also,” *Ensign* or *Liahona*, Nov. 2012, 15–16).

 **5.** Write the following at the bottom of today’s assignments in your scripture study journal:

*I have studied Doctrine and Covenants 72–74 and completed this lesson on (date).*

*Additional questions, thoughts, and insights I would like to share with my teacher:*

## UNIT 16: DAY 2

# Doctrine and Covenants 75

## Introduction

At a conference of the Church held on January 25, 1832, the Prophet Joseph Smith received two revelations, which are both found in Doctrine and Covenants 75. The first revelation, recorded in verses 1–22, was given to a group of elders who had submitted their names for missionary service. The Lord instructed these elders concerning their missionary duties and assigned them mission companions. The second revelation, recorded in verses 23–36, was given to a second group of elders who wanted to know the Lord’s will concerning them. The Lord instructed these elders to ensure that their families would be provided for and to accept a call to preach the gospel.

## Doctrine and Covenants 75:1–5

*The Lord addresses those who desire to preach the gospel*

How many years are there until you will be eligible to serve a full-time mission? As you think about the possibility of serving a full-time mission, what blessings do you anticipate you would receive by

sharing the gospel with others? On the space provided, write some of those blessings: \_\_\_\_\_

As recorded in Doctrine and Covenants 75, the Lord promised many blessings to those whom He called to preach the gospel. He also gave them instructions to help them be successful. Read Doctrine and Covenants 75:1–4, looking for what the Lord wanted the elders to do while preaching the gospel. You may want to mark what you discover in your scriptures.

 **1.** In your scripture study journal, write why you think it is important that missionaries preach the gospel in the manner the Lord described in these verses.

Read Doctrine and Covenants 75:5, looking for what the Lord promised the elders if they would faithfully proclaim His gospel. It may be helpful to know that the word *sheaves* refers to stalks of grain that are cut and tied into bundles. Having “many sheaves” means having an abundant harvest. What do you think “sheaves” could represent in missionary work?



Sheaves in a field

In addition to the blessing of receiving the fruits of our labors as we share the gospel with others, the Lord promised eternal blessings in Doctrine and Covenants 75:5. How might the Lord’s promises in verse 5 encourage you to share the gospel with others?

 **2.** Using what you learn in verse 5, complete the following principle in your scripture study journal: ***If we are faithful in proclaiming the gospel, the Lord will bless us with . . .***

## Doctrine and Covenants 75:6–22

### *The Lord calls and instructs missionary companionships*

After the Lord gave instructions and promises to the elders who were going to serve missions, He grouped them into companionships and gave each companionship specific instructions.

Read Doctrine and Covenants 75:6–12 to learn about the first companionship and the promise the Lord gave them if they faithfully proclaimed the gospel.

It may help you to know that on October 29, 1831, William E. McLellin had received a call to serve a mission to the eastern United States, and Samuel H. Smith was called as his companion (see D&C 66:5–8). William initially obeyed this call. His mission ended early, and he returned to Kirtland, Ohio, at the end of December 1831. As recorded in Doctrine and Covenants 75:6–12, the Lord rebuked William E. McLellin for his murmurings, revoked the call to serve in the eastern states, and called Orson Hyde to replace him as Samuel Smith’s companion. However, the Lord mercifully extended another call for William to proclaim the gospel in the southern United States with Luke Johnson as his companion. William accepted the call to serve, but he did not continue faithfully. He soon claimed to be too sick to continue his mission. After leaving his mission, he traveled to Hiram, Ohio, and married Emiline Miller.

Read Doctrine and Covenants 75:11, 13–14, looking for the promise the Lord repeated to each of those missionary companionships if they would be faithful in proclaiming the gospel. You may wish to mark the phrases in these verses that assure us that ***if we are faithful in proclaiming the gospel, the Lord will be with us.***

 **3.** In your scripture study journal, write about an experience you or someone you know has had that assures you that the Lord will be with us as we faithfully share His gospel with others.

 **4.** Imagine that you have a friend or family member who is struggling while serving a full-time mission. In your scripture study journal, write a letter of encouragement to this person, using the principles you have learned in today’s lesson. In your letter, share what missionaries can do to more faithfully proclaim the gospel and what some of the blessings are that come to those who do so. (If you know a full-time missionary, you could write the letter to him or her. Then write a note in your scripture study journal stating you did that.)





Gordon B. Hinckley as a missionary in England, preaching in London's Hyde Park

We may face challenges in our efforts to be faithful in proclaiming the gospel. In an article about President Gordon B. Hinckley, Elder Jeffrey R. Holland of the Quorum of the Twelve Apostles wrote about a struggle President Hinckley faced while serving as a young missionary in England:

“Elder Hinckley found some of that discouragement common to missionaries facing new circumstances in a new land. He was not well physically, and as he went to his first street meeting . . . , he recalls: ‘I was terrified. I stepped up on that little stand and looked at that crowd of people that had gathered. . . . They looked rather menacing and mean, but I somehow stumbled through whatever I had to say.’

“Down in spirit and facing no success in missionary endeavors, Gordon wrote a letter to his father, saying: ‘I am wasting my time and your money. I don’t see any point in my staying here.’ In due course a gentle but terse reply came from his father. That letter read: ‘Dear Gordon. I have your letter [of such and such a date]. I have only one suggestion. Forget yourself and go to work. With love, Your father.’

“President Hinckley says of that moment, ‘I pondered his response and then the next morning in our scripture class we read that great statement of the Lord: “For whosoever will save his life shall lose it; but whosoever shall lose his life for my sake and the gospel’s, the same shall save it” (Mark 8:35).

“That simple statement, that promise, touched me. I got on my knees and made a covenant with the Lord that I would try to forget myself and go to work. I count that as the day of decision in my life. Everything good that has happened to me since then I can trace back to the decision I made at that time” (“President Gordon B. Hinckley: Stalwart and Brave He Stands,” *Ensign*, June 1995, 8.)

As recorded in Doctrine and Covenants 75:15–22, the Lord instructed the missionaries to bless the households of those who received them. He also taught them what to do when they were rejected by those they shared the gospel with. Shaking off the dust of their feet as a testimony against those who reject them is not practiced by missionaries today.

### Doctrine and Covenants 75:23–29

*The Lord explains how the families of those He called to serve missions should be supported*

The second revelation in Doctrine and Covenants 75, recorded in verses 23–36, was given to a different group of elders. In the early years of the Church, many men who were called to serve missions had wives and children who depended on them for support. Accepting the call to serve was a great sacrifice for the whole family. A natural concern for many elders would have been what would happen to their families if they accepted a call to preach the gospel far from home.

Read Doctrine and Covenants 75:24–28, looking for the Lord’s instructions to the elders who were needed to preach the gospel but had families to care for.

In these verses the Lord said that the Church should help the family when a father or husband accepts the call to leave to serve a mission. Notice in verse 26 what



the Lord directed the elders to do if they were able to find a place where their families would be supported.

In verse 28, the Lord told the elders who were not able to find other support for their families that they were excused from traveling, and He assured them that they would not lose their chance of receiving eternal life. These elders were still expected to labor in the Church locally.

Read Doctrine and Covenants 75:29, looking for the counsel the Lord gave to all of these men. It may be helpful to know that an idler is an individual who is unwilling to work and that to “be diligent in all things” means to be consistent, persistent, attentive, and hardworking.

You may want to mark the Lord’s instruction in verse 29 that teaches the following principle: **The Lord commands us to be diligent in all things.**

 **5.** Ponder some aspects of your life in which you feel you can be more diligent. On a separate piece of paper, write a goal of one thing you will do to be more diligent. Post this goal where you can see it daily. Once you have done this, write in your scripture study journal: *I have written my goal and placed it where I can see it daily.*

## Doctrine and Covenants 75:30–36

*The Lord assigns elders to serve as missionary companions*

At the end of the second revelation recorded in Doctrine and Covenants 75, the Lord assigned this group of elders into missionary companionships.



**6.** Write the following at the bottom of today’s assignments in your scripture study journal:

*I have studied Doctrine and Covenants 75 and completed this lesson on (date).*

*Additional questions, thoughts, and insights I would like to share with my teacher:*

## UNIT 16: DAY 3

# Doctrine and Covenants 76:1–49

## Introduction

On February 16, 1832, the Prophet Joseph Smith and Sidney Rigdon were working on inspired revisions to the Bible. While they were pondering the meaning of John 5:29, they were shown a vision. This vision, which is recorded in Doctrine and Covenants 76, affirmed the reality and divinity of Jesus Christ, taught about the fall of Satan and the sons of perdition, and described the three kingdoms of glory and those who will inherit each kingdom.

Doctrine and Covenants 76 will be studied in three lessons. In this first lesson you will learn about the Lord’s willingness to bless us and about the actions of the Prophet Joseph Smith and Sidney Rigdon that led to them receiving the vision. You will also learn about the fall of Satan and the fate of those who follow him.



**The Glory of the Father and the Son**  
(verses 19–24)

**The Fall of Lucifer Sons of Perdition**  
(verses 25–27) (verses 30–49)



**The Celestial Glory**  
(verses 50–70, 92–96)



**The Terrestrial Glory**  
(verses 71–80, 87, 91, 97)



**The Telestial Glory**  
(verses 81–86, 88–90, 98–112)

**Doctrine and Covenants 76**  
**Outline of the Vision**

## Doctrine and Covenants 76:1–10

*The Lord promises blessings to those who are faithful to Him*

If you could select one person to be honored by, who would it be and why?

Doctrine and Covenants 76:1–5 teaches that the Lord is wise, powerful, eternal, merciful, and charitable. Verse 5 also teaches that He will honor us if we qualify. Read verse 5, and identify what we must do to be honored by Jesus Christ.

In this context, to fear the Lord means to revere, honor, respect, and love Him. Based on the Lord’s words in verse 5, we learn that **if we revere and serve the Lord, He will honor us**.

Read Doctrine and Covenants 76:6–9, looking for ways the Lord will honor those who revere and serve Him. As you read, it might be helpful to know that in the scriptures the term *mysteries* generally refers to spiritual truths that can only be learned through revelation.

According to what you read in verses 6–9, add to the previous principle: **If we revere and serve the Lord, He will honor us by \_\_\_\_\_.**

Read Doctrine and Covenants 76:10, and identify a principle regarding how the Lord will reveal truth to us.

 **1. Ponder the principle that the Lord enlightens us by the Spirit.** To help you remember times when the Lord has enlightened you by the Spirit, complete the following in your scripture study journal: *I recently felt enlightened by the Spirit when I . . .*

## Doctrine and Covenants 76:11–19

*Joseph Smith and Sidney Rigdon describe the circumstances that led to their vision*



The vision recorded in Doctrine and Covenants 76 was received in the John Johnson farm, in Hiram, Ohio.

The vision that was shown the Prophet Joseph Smith and Sidney Rigdon is a fulfillment of the Lord’s promises in Doctrine and Covenants 76:5–10. Read Doctrine and Covenants 76:11–14, and notice how the Lord honored Joseph Smith and Sidney Rigdon by revealing truth to them.

Have you ever spent time reading the scriptures and not understood what you read? What have you done to better understand the scriptures?

What Joseph Smith and Sidney Rigdon were doing before they were shown this vision can teach us how we can better understand the scriptures and invite the Spirit to reveal truth to us. Read the section introduction for Doctrine and Covenants 76, and then read Doctrine and Covenants 76:15–19. As you read, look for what Joseph and Sidney were doing that enabled them to receive understanding of the scriptures through revelation.

Notice that it was while they were studying and meditating on the scriptures that the Spirit enlightened their understandings. To meditate on the scriptures means to ponder or think about what you read. Joseph and Sidney’s example shows us that **if we prayerfully study and ponder the scriptures, the Lord can increase our understanding**.



Elder D. Todd Christofferson of the Quorum of the Twelve Apostles explained how to prayerfully study and ponder the scriptures: “When I say ‘study,’ I mean something more than reading. . . . I see you sometimes reading a few verses, stopping to ponder them, carefully reading the verses again, and as you think about what they mean, praying for understanding, asking questions in your mind, waiting for spiritual impressions, and writing down the impressions and insights that come so you can remember and learn more. Studying in this way, you may not read a lot of chapters or verses in a half hour, but you will be giving place in your heart for the word of God, and He will be speaking to you” (“When Thou Art Converted,” *Ensign* or *Liahona*, May 2004, 11).

 **2. Respond to the following in your scripture study journal:**

- a. What results have you experienced by prayerfully studying and pondering the scriptures?
- b. Write one action mentioned by Elder Christofferson that you will apply in your personal study of the scriptures.

## Doctrine and Covenants 76:20–24

*Joseph Smith and Sidney Rigdon see Heavenly Father and Jesus Christ*

As the vision unfolded, the Prophet Joseph Smith and Sidney Rigdon saw Jesus Christ in His majesty and glory.



3. Draw a chart with the following three headings in your scripture study journal:

What they saw:	What they heard:	What they learned:
----------------	------------------	--------------------

- Read Doctrine and Covenants 76:20–24, and write words or phrases from these verses that fit under the applicable headings.
- Based on what Joseph Smith and Sidney Rigdon saw, heard, and learned, list at least two truths about Jesus Christ that are taught in these verses. Then write your testimony regarding one of these truths and how you know or why you believe it is true.

## Scripture Mastery—D&C 76:22–24

Doctrine and Covenants 76:22–24 is a scripture mastery passage. You may want to mark it in a distinctive way to help you locate it in the future.



4. The Prophet Joseph Smith and Sidney Rigdon bore witness that Jesus Christ is a living, glorified Being. Find two other examples in the scriptures of times when someone else saw the resurrected Savior. Use the footnotes, Topical Guide, or Guide to the Scriptures to assist you. Write the references for the examples you find in your scripture study journal.

## Doctrine and Covenants 76:25–29

*Joseph Smith and Sidney Rigdon see in vision the fall of Satan*

Complete the following quiz by marking whether each statement is true (T) or false (F).

- \_\_\_ 1. Satan was known as Lucifer.
- \_\_\_ 2. Satan was a spirit in authority in the presence of God.
- \_\_\_ 3. Satan did not mean to disobey Heavenly Father and Jesus Christ.
- \_\_\_ 4. There was rejoicing in heaven when Satan was cast out.
- \_\_\_ 5. Satan makes war with the Saints of God.

After you have completed the quiz, review Doctrine and Covenants 76:25–29, which describes the Prophet Joseph Smith and Sidney Rigdon’s vision of the fall

of Satan. Make any changes to your answers based on what you read, and then check your answers with those at the end of this lesson.

## Doctrine and Covenants 76:30–49

*Joseph Smith and Sidney Rigdon see in vision the sufferings of the sons of perdition*

During a war, what is a traitor? Doctrine and Covenants 76:30–49 is about individuals who choose to become traitors to the Savior. These individuals are known as sons of perdition. Read Doctrine and Covenants 76:30–35, looking for the choices that lead individuals to become sons of perdition.

Sons of perdition are different from Church members who once had active testimonies of the truth but later fall away from activity and following the principles of the gospel. Sons of perdition commit the unpardonable sin of denying the Holy Ghost.

The Prophet Joseph Smith taught the following about the unpardonable sin: “What must a man do to commit the unpardonable sin? He must receive the Holy Ghost, have the heavens opened unto him, and know God, and then sin against him. After a man has sinned against the Holy Ghost, there is no repentance for him.

He has got to say that the sun does not shine while he sees it; he has got to deny Jesus Christ when the heavens have been opened unto him, and to deny the plan of salvation with his eyes open to the truth of it” (in *History of the Church*, 6:314).

Committing the unpardonable sin requires a special knowledge of the Savior gained through a sacred experience with Him. President Spencer W. Kimball helped us understand what this means for most members of the Church: “The sin against the Holy Ghost requires such knowledge that it is manifestly impossible for the rank and file to commit such a sin” (*The Miracle of Forgiveness* [1969], 123).

Read Doctrine and Covenants 76:36–38, 44–49, looking for the condition of sons of perdition.

### Cross-References

Often, one scripture passage can explain or clarify a phrase or concept found in a different passage. Link scripture passages to each other by using the scripture footnotes, index, or the Topical Guide or Guide to the Scriptures to help unlock the meaning of a scripture passage.

Sons of perdition will not be redeemed from spiritual death, or the second death, and will not inherit a kingdom of glory after they are resurrected. Instead, they will suffer for eternity.

During the vision of the sons of perdition, the Prophet Joseph Smith and Sidney Rigdon learned a principle of hope. Read Doctrine and Covenants 76:39–43, looking for words and phrases that teach the following principle: **Through the Atonement of Jesus Christ, all of God’s children, except the sons of perdition, can be saved from both sin and death.**

### Scripture Mastery—Doctrine and Covenants 76:40–41

Read Doctrine and Covenants 76:40–41. Because this passage is a scripture mastery scripture, you may want to mark it in a distinctive way to help you locate it in the future. The word *gospel* means good news.

 **5.** In your scripture study journal, write a short headline summing up the good news taught in Doctrine and Covenants 76:40–41. Then write a few sentences describing why this is good news to you. You may want to write out the passage and place it somewhere where you can work on memorizing it during the next few days.

 **6.** Write the following at the bottom of today’s assignments in your scripture study journal:

*I have studied Doctrine and Covenants 76:1–49 and completed this lesson on (date).*

*Additional questions, thoughts, and insights I would like to share with my teacher:*

Answers to the true–false assignment:

Statement 1 is true (see D&C 76:26, 28).

Statement 2 is also true (see D&C 76:25–27). The name Lucifer means lightbringer or shining one. Lucifer was “a son of the morning,” which indicates that “he was one of the early born spirit children of the Father” (Bruce R. McConkie, *Mormon Doctrine*, 2nd ed. [1966], 744).

Statement 3 is false (see D&C 76:25, 28). Satan sought to dethrone Heavenly Father and take His power, kingdom, and glory. **In the premortal existence, Lucifer rebelled against Heavenly Father and Jesus Christ and was cast out.**

Statement 4 is also false (see D&C 76:26). The heavens wept over the loss of Lucifer, and he was given the title of Perdition, which means destruction or damnation.

Statement 5 is true (see D&C 76:29). Consider marking the phrase in verse 29 that teaches that **Satan makes war with the Saints of God**. Ponder the ways in which you have seen that Satan is waging war against the Saints of God today.

## UNIT 16: DAY 4

# Doctrine and Covenants 76:50–80

## Introduction

After seeing in vision the glory of the Son, the fall of Lucifer, and the condition of sons of perdition, the Prophet Joseph Smith and Sidney Rigdon were shown those who will take part in the resurrection of the just: the inhabitants of the celestial and terrestrial kingdoms.

## Doctrine and Covenants 76:50–70

*The Lord reveals the requirements for and blessings of receiving celestial glory*



The room where the vision recorded in Doctrine and Covenants 76 was received.



While working on the translation of the Bible on February 16, 1832, the Prophet Joseph Smith made inspired changes to the wording of John 5:29 pertaining to the resurrections of the just and the unjust (see D&C 76:15–17). He and Sidney Rigdon were pondering John’s description of the resurrection of the just and the resurrection of the unjust when they received the vision included in Doctrine and Covenants 76. Read Doctrine and Covenants 76:50, looking for whom Joseph Smith and Sidney Rigdon were shown following the vision of the sons of perdition. (As you read, it may be helpful to know that in this verse the word *just* means righteous. You may want to write this definition in the margin of your scriptures next to Doctrine and Covenants 76:50.)

Read Doctrine and Covenants 76:70, and mark who were in the first group of people Joseph and Sidney saw who will be resurrected during the resurrection of the just. As a part of this vision, the Lord revealed the qualities of those who will inherit the celestial kingdom.

-  **1.** Write the heading *Becoming a Celestial Person* in your scripture study journal. Read Doctrine and Covenants 76:51–53, and under the heading in your scripture study journal, list the qualities described in these verses for those who will inherit the celestial kingdom. Try to find at least four qualities.

### Scripture Lists

The scriptures often contain lists of things, such as instructions or warnings. When you find lists, consider numbering each element.

To help you better understand a few of the phrases you identified, it may be helpful to know that to “[receive] the testimony of Jesus” (D&C 76:51) is to obtain a testimony by personal revelation that Jesus Christ is the Savior

and to act according to that testimony in your life. To “overcome by faith” (D&C 76:53) is to overcome temptations and sins by exercising faith in Jesus Christ. An individual is “sealed by the Holy Spirit of promise” (D&C 76:53; see also D&C 132:7) when the Holy Ghost confirms that the priesthood ordinances received and the covenants made are acceptable to God. This approval depends on a person’s faithfulness.

-  **2.** To help you further understand the qualities of a celestial person, answer one or more of the following questions in your scripture study journal:
- What have you done to receive the testimony of Jesus Christ and to keep that testimony strong?

- What can you do to better receive the testimony of Jesus Christ?
- How does receiving the testimony of Jesus Christ and keeping His commandments help someone become more worthy of the celestial kingdom?



In addition to revealing some of the qualities of those who will inherit the celestial kingdom, the Lord went on to describe some of the blessings the inhabitants of the celestial kingdom will receive. Read Doctrine and Covenants 76:54–68, and identify these blessings.

Consider marking the blessings that are especially meaningful to you.

Read Doctrine and Covenants 76:69–70, looking for what happens to those who are worthy of the celestial kingdom. As you read, it might be helpful to know that the word *perfect* in verse 69 does not mean flawless; it means complete. (Matthew 5:48 footnote *b* explains that alternate translations from the Greek word are “complete, finished, fully developed.”)

While our best efforts to keep all of the commandments do not make us perfect, our efforts do make it possible for us to receive the Savior’s grace and to be cleansed by His “perfect atonement through the shedding of his own blood” (D&C 76:69). Each of us can be made perfect through Jesus Christ and be exalted with our families in the highest degree of the celestial kingdom (see Moroni 10:32–33). This truth can encourage us to keep the commandments and receive the ordinances of salvation so we can receive these great blessings. Thus, **we can be made perfect through the Atonement of Jesus Christ.** You may want to write this principle under the “Becoming a Celestial Person” heading in your scripture study journal.

-  **3.** Answer the following questions in your scripture study journal:

- How do the principles taught in Doctrine and Covenants 76:69–70 strengthen your faith and inspire you to seek exaltation in the celestial kingdom?
- How might the principles taught in these verses help us overcome discouragement as we strive for celestial glory?

## Doctrine and Covenants 76:71–80

*Joseph Smith and Sidney Rigdon are shown in vision the terrestrial kingdom*

If you were to ask your friends if they believe they can inherit the celestial kingdom—to return to live eternally with Heavenly Father with their families—how many do you think would say they believe they can? Do you believe *you* can inherit the celestial kingdom?

Bishop Joseph L. Wirthlin of the Presiding Bishopric testified, “We are all candidates for the celestial kingdom” (in Conference Report, Apr. 1952, 118). You may want to write this statement in your scripture study journal or the margin of your scriptures.

Although all people are candidates for the celestial kingdom, some choose not to live up to their potential. Read Doctrine and Covenants 76:71, and mark what the Prophet Joseph Smith and Sidney Rigdon next saw in vision.

Notice how the scriptures use the difference between the reflected light from the moon and the light that radiates directly from the sun to symbolize the difference between the glories of the terrestrial and celestial kingdoms. While inhabitants of the celestial and terrestrial kingdoms are both included in the resurrection of the just, those obtaining celestial bodies will be resurrected with greater glory and blessings than those obtaining terrestrial bodies.

Read Doctrine and Covenants 76:72–80, looking for how the inhabitants of the terrestrial kingdom differ from the inhabitants of the celestial kingdom.

Review Doctrine and Covenants 76:71–79, and mark what you find about who will inherit the terrestrial kingdom. “Remember that only God, who knows each individual’s heart, can make final judgments of individuals (see Revelation 20:12; 3 Nephi 27:14; D&C 137:9)” (*True to the Faith: A Gospel Reference* [2004], 90). Only the Lord can know our heart; we should be cautious not to make judgments of which kingdom we believe others will inherit.

 **4.** Answer the following question in your scripture study journal: How are some people today being blinded by the craftiness of men?

One significant difference between people who inherit the celestial and terrestrial kingdoms is what they do with their testimonies of Jesus Christ. Those who inherit the terrestrial kingdom “are not valiant in the testimony



of Jesus” (D&C 76:79). Elder Bruce R. McConkie of the Quorum of the Twelve Apostles explained:

“What does it mean to be valiant in the testimony of Jesus?

“It is to be courageous and bold; to use all our strength, energy, and ability in the warfare with the world; to fight the good fight of faith. . . . The great cornerstone of valiance in the cause of righteousness is obedience to the whole law of the whole gospel. . . .

“To be valiant in the testimony of Jesus is to believe in Christ and his gospel with unshakable conviction. It is to know of the verity [truthfulness] and divinity of the Lord’s work on earth.

“But this is not all. It is more than believing and knowing. We must be doers of the word and not hearers only. It is more than lip service; it is not simply confessing with the mouth the divine Sonship of the Savior. It is obedience and conformity and personal righteousness. . . .

“To be valiant in the testimony of Jesus is to . . . ‘endure to the end.’ (2 Ne. 31:20.) It is to live our religion, to practice what we preach, to keep the commandments” (“Be Valiant in the Fight of Faith,” *Ensign*, Nov. 1974, 35).

Each of us has the potential to obtain the celestial kingdom through the choices we make. As taught in the scriptures you have studied in this lesson, **if we are valiant in the testimony of Jesus, we can obtain the celestial kingdom of God.** Add this principle under the “Becoming a Celestial Person” heading in your scripture study journal.

 **5.** Answer the following questions in your scripture study journal:

- Think of someone you know whom you would consider to be valiant in the testimony of Jesus Christ. What characteristics and actions demonstrate his or her valiance?
- What has helped you be valiant in your testimony of Jesus Christ?

 **6.** Write the following at the bottom of today’s assignments in your scripture study journal:

*I have studied Doctrine and Covenants 76:50–80 and completed this lesson on (date).*

*Additional questions, thoughts, and insights I would like to share with my teacher:*

**UNIT 17: DAY 1**

# Doctrine and Covenants 76:81–119; 77

## Introduction

This lesson explores the vision of the telestial kingdom shown to the Prophet Joseph Smith and Sidney Rigdon, as recorded in Doctrine and Covenants 76. This revelation was given at Hiram, Ohio, on February 16, 1832. Joseph and Sidney described what they learned about those who will inherit the telestial kingdom and the consequences of rejecting the gospel and testimony of Jesus Christ. They also described how the telestial kingdom differs from the other kingdoms of glory and explained what individuals must do to qualify to see and understand for themselves the mysteries of the kingdom of God. Later, in March 1832, Joseph Smith recorded the Lord’s answers to his questions about the Book of Revelation. This revelation is found in Doctrine and Covenants 77.

## Doctrine and Covenants 76:81–112

*The Lord shows Joseph Smith and Sidney Rigdon a vision of the telestial kingdom*

### Contrasts

The scriptures often show contrasts between ideas, events, and people. These contrasts emphasize gospel principles. Look for such contrasts in single verses, in chapters, and across chapters and books. For example, in Doctrine and Covenants 76, the revelation contrasts the sons of perdition with those who qualify for the kingdoms of glory.

Imagine you are having a religious discussion with a friend who is a member of a different Christian church. Your friend says, “At church last Sunday, my minister told us that after we die we are going to either heaven or hell. I don’t feel like I’m good enough to go to heaven right now, but I also don’t feel like I’m so bad that I should go to hell. What does your religion teach about heaven and hell?”

Look at the “Doctrine and Covenants 76: Outline of the Vision” diagram from the Unit 16: Day 3 lesson in this study guide. Notice that the last kingdom of glory the Prophet Joseph Smith and Sidney Rigdon saw in vision was

the telestial kingdom. Read Doctrine and Covenants 76:81–83, 103, looking for words and phrases that describe the people who will inherit the telestial kingdom. You may want to mark what you find.

In verse 103, *sorcerers* are people who seek to control and use power through the aid of evil sources. *Whoremongers* are people who engage in fornication and other sexual sins.

One of the criteria that determine which kingdom of glory a person inherits is how he or she responds to the gospel and testimony of Jesus Christ. Read the scripture references in the following chart. In the space provided, describe how the future inhabitants of these kingdoms respond to the gospel and testimony of Jesus Christ.

Kingdom	Responses to the Gospel and Testimony of Jesus Christ
Celestial (D&C 76:50–51)	
Terrestrial (D&C 76:74, 79)	
Telestial (D&C 76:82, 101)	



1. Answer the following questions in your scripture study journal:

- a. In what ways are you seeking to strengthen your testimony of Jesus Christ?
- b. Why do you think a person’s response to the gospel and testimony of Jesus Christ has such an important influence on which kingdom he or she will inherit?
- c. How can you be valiant in your testimony of Jesus Christ?

Read Doctrine and Covenants 76:84–85, 104–6, and mark phrases that teach the following truth: **Those who will inherit the telestial kingdom must suffer in hell before they will be redeemed by the Savior.**

It is helpful to know that the scriptures use the term *hell* in at least two ways. First, hell is the part of the spirit world inhabited by the wicked and is a literal but temporary condition of spiritual torment and suffering (see Doctrine and Covenants 76:84–85, 104–6).

“Eternal fire” is a figurative expression referring to the excruciating torment and suffering that will occur in hell. Secondly, the scriptures sometimes use the word *hell* to refer to outer darkness, which sometimes refers to the permanent condition of torment and suffering that continues for sons of perdition after they are resurrected and judged, as well as for Satan and his followers from the premortal life. (See Bible Dictionary, “Hell”; Guide to the Scriptures, “Hell”; scriptures.lds.org.)

Elder James E. Talmage of the Quorum of the Twelve Apostles taught the following about hell:



“To hell there is an exit as well as an entrance. . . . It is a place prepared for the teaching, the disciplining of those who failed to learn here upon the earth what they should have learned” (in Conference Report, Apr. 1930, 97).

“As to the duration of the punishment, we may take assurance that it will be graded according to the sin; and that the conception of every sentence for misdeeds being interminable [endless] is false [see D&C 19:6–12; 76:36, 44]. Great as is the effect of this life upon the hereafter, and certain as is the responsibility of opportunities lost for repentance, God holds the power to pardon beyond the grave. Yet the scriptures speak of eternal and endless punishment. Any punishment ordained of God is eternal, for He is eternal [see D&C 19:10–12]. His is a system of endless punishment, for it will always exist as a place or condition prepared for disobedient spirits; yet the infliction of the penalty will have an end in every case of acceptable repentance and reparation” (*The Articles of Faith*, 12th ed. [1924], 60–61).

What phrases from Doctrine and Covenants 76:85, 106 teach that hell will be a temporary condition for those who will inherit the telestial kingdom?

President Joseph Fielding Smith explained the result of suffering in hell for those who will inherit the telestial kingdom: “This suffering will be a means of cleansing, or purifying, and through it the wicked shall be brought to a condition whereby they may, through the redemption of Jesus Christ, obtain immortality. Their spirits and bodies shall be again united, and they shall dwell in the telestial kingdom. But this resurrection will not come until the end of the world” (*Doctrines of Salvation*, comp. Bruce R. McConkie, 3 vols. [1954–56], 2:298).

In Doctrine and Covenants 76:106–8, we learn that the wicked will suffer for their sins until Jesus Christ completes His work and delivers up the kingdom of God on earth to His Father, which will occur after the Millennium. Christ will then be crowned with glory.

Read Doctrine and Covenants 76:111 and Doctrine and Covenants 137:9, looking for what will determine the kingdom of glory we inherit.

One principle we can learn from these verses is that **the kingdom of glory we inherit will be determined by our actions in this life and the desires of our hearts.**



The following statement by Elder Russell M. Nelson of the Quorum of the Twelve Apostles can help you further understand this principle: “Each of you will be judged according to your individual works and the desires of your hearts [see D&C 137:9]. You will not be required to pay the debt of any other. Your eventual placement in the celestial, terrestrial, or telestial kingdom will not be determined by chance. The Lord has prescribed unchanging requirements for each. You can know what the scriptures teach and pattern your lives accordingly [see John 14:2; 1 Corinthians 15:40–41; D&C 76:50–119; 98:18]” (“Constancy amid Change,” *Ensign*, Nov. 1993, 35).



**2. Answer the following question in your scripture study journal: How can understanding this principle influence the choices you make today?**

Read Doctrine and Covenants 76:86–89, 98, 112, looking for words or phrases that describe what immortality will be like for those who inherit the telestial kingdom. You may want to mark what you find.

As the Prophet Joseph Smith and Sidney Rigdon described the inhabitants of the telestial kingdom, they included an explanation of how the three kingdoms of glory compare with each other. Read Doctrine and Covenants 76:91–98, looking for how the kingdoms compare with each other in glory.

In what ways does the glory of the celestial kingdom differ from the glory of the terrestrial and telestial kingdoms? \_\_\_\_\_

\_\_\_\_\_





The difference in glory between the celestial, terrestrial, and telestial kingdoms can be illustrated by the differences in the brightness of the sun, moon, and stars as viewed from the earth. When viewed from the earth, the brightest stars are about 100 times brighter than the dimmest stars. The moon is about 30,000 times brighter than the brightest stars. The sun is about 400,000 times brighter than the full moon. These differences in brightness help illustrate the differences Joseph and Sidney observed between the kingdoms of glory. As you can see from Doctrine and Covenants 76:94–95, the blessings received by those who qualify for celestial glory are magnificently greater than the blessings received by those who inherit the telestial kingdom.

### Doctrine and Covenants 76:113–19

*Joseph Smith and Sidney Rigdon explain what individuals must do to qualify to see and understand for themselves the mysteries of the kingdom of God*

Doctrine and Covenants 76:113–19 contains the Prophet Joseph Smith and Sidney Rigdon’s explanation that they were commanded not to write all that they were shown. They also explained what others must do to qualify to see and understand for themselves the mysteries of the kingdom of God. Read Doctrine and Covenants

76:116, looking for how a person can qualify to see and understand the mysteries of the kingdom of God by the power of the Holy Spirit.

According to verse 116, what must a person do to qualify to see and understand the mysteries of the kingdom of God by the power of the Holy Spirit?

 **3.** In your scripture study journal, write a response to the imagined scenario presented at the beginning of this lesson, in which a friend asked what the Church teaches about heaven and hell. Answer the following questions as part of your response to your friend’s question.

- a. What has the Lord revealed about heaven and hell in Doctrine and Covenants 76?
- b. What are the differences between each kingdom of glory and outer darkness?
- c. What are the differences in the choices made by those who inherit the different kingdoms and outer darkness?

 **4.** To help you apply what you have learned from studying Doctrine and Covenants 76, complete each of the following statements in your scripture study journal:

*As a result of what I have learned from studying Doctrine and Covenants 76:*

- a. *I believe or know that . . .*
- b. *I want . . .*
- c. *I will . . .*

### Doctrine and Covenants 77

*The Lord reveals answers to Joseph Smith’s questions about the book of Revelation*

Turn to Doctrine and Covenants 77, and notice how the verses are formatted differently from verses in other sections in the Doctrine and Covenants. Read the section introduction to Doctrine and Covenants 77, looking for what the Prophet Joseph Smith was doing when he received this revelation.

From March 1831 to July 1833, the Prophet Joseph Smith made inspired revisions to the New Testament. (Many of these revisions are listed in the Latter-day Saint edition of the King James Version of the Bible footnotes as JST and in the Joseph Smith Translation section in the appendix, with the changed words written in italics.) While working on the book of Revelation, the Prophet asked the Lord about the meaning of some of the verses. Joseph’s questions and the Lord’s answers are recorded in Doctrine and Covenants 77. Review some of these verses, and notice how each *Q* precedes a question that Joseph Smith asked the Lord, and each *A* precedes the Lord’s response.



## UNIT 17: DAY 2

# Doctrine and Covenants 78–80

### Introduction

On March 1, 1832, the Lord revealed to the Prophet Joseph Smith the revelation now recorded in Doctrine and Covenants 78. In this revelation the Lord directed the Prophet to organize a firm (later known as the United Firm) to manage the storehouses and publishing efforts of the Church. The Lord also described the blessings the Saints would receive if they obeyed the commandment to organize this firm. In an effort to protect this Church-operated business from enemies of the Church, some of the language of this revelation was changed when it was first published in the 1835 edition of the Doctrine and Covenants. For example, the word *firm* was changed to *order* (see D&C 78:4).

Around the same time that the Lord commanded Joseph Smith to organize the United Firm, the Lord gave the revelations recorded in Doctrine and Covenants 79–80. In these revelations the Lord called Jared Carter, Stephen Burnett, and Eden Smith to serve as missionaries.

### Doctrine and Covenants 78:1–16

*The Lord commands the Prophet Joseph Smith to organize the United Firm*

Money is an important part of the world in which we live, and it can be used for righteous or evil purposes. In the space below, list several ways money can be used for righteous purposes and several ways it can be used for evil purposes.

### Pondering Questions

Pondering questions as you study the scriptures will stimulate your desire to search the scriptures for answers. It will also increase your ability to understand the doctrines and principles you identify in the scriptures and to apply them in your life. Consider writing down some of your own questions to ponder as you study the scriptures. These might include questions about the meaning of a word or phrase, the historical background of what you are reading, or the importance of a particular verse.

Joseph Smith's experience with receiving the revelation in Doctrine and Covenants 77 teaches us that **the Lord reveals the correct interpretation of scripture through His prophets**. We can also learn that **if we inquire of the Lord, He can help us understand the scriptures**.

It may be helpful to understand that in Doctrine and Covenants 77:6, the 7,000 years is in reference to the earth's temporal existence, meaning since the Fall of Adam. It is not commenting on the age of the earth.

 **5.** Write the following at the bottom of today's assignments in your scripture study journal:

*I have studied Doctrine and Covenants 76:81–119; 77 and completed this lesson on (date).*

*Additional questions, thoughts, and insights I would like to share with my teacher:*

Righteous Purposes	Evil Purposes

In May 1831, the Lord commanded that a storehouse be established to gather excess goods and money for the benefit of the poor (see D&C 51). The Church also needed funds to buy land and to finance the publication of the revelations the Prophet Joseph Smith had received. Three separate organizations existed to generate these funds: (1) the Newel K. Whitney store in Kirtland, Ohio, (2) a store run by Sidney Gilbert in Missouri, and (3) the Literary Firm, which had been established to oversee the printing of Church publications. The Lord’s instructions in Doctrine and Covenants 78:3 led to combining these



three organizations into one. The new organization would be called the United Firm and would consist of Joseph Smith, Sidney Rigdon, Newel K. Whitney,

Edward Partridge, Sidney Gilbert, Oliver Cowdery, John Whitmer, William W. Phelps, and Martin Harris.

In Doctrine and Covenants 78, the word *order* refers to the United Firm. Read Doctrine and Covenants 78:3–4, looking for what this firm, or order, would allow the Saints to do.

 **1.** Answer the following question in your scripture study journal: According Doctrine and Covenants 78:4, what is the cause that the Lord wanted to advance through the United Firm?

Read Doctrine and Covenants 78:5–6, looking for reasons why the Lord commanded that the Saints help “the poor of [His] people” (D&C 78:3).

As mentioned in these verses, heavenly things include blessings of an eternal nature, such as knowledge, testimony, and opportunities to receive the saving ordinances.

It may be helpful to know that being equal in earthly things does not imply that everyone will have exactly the same possessions, but rather that every family will have sufficient resources for their needs and wants, according to their individual circumstances.

 **2.** In your scripture study journal, write a few sentences explaining how you think being equal in earthly things allows us to be equal in obtaining heavenly things.

Read Doctrine and Covenants 78:7. As you read, look for an additional reason why the Lord commanded the Saints to form the United Firm and care for the poor. Then complete the following principle: **Doing the things the Lord has commanded prepares us for**

---



---

How do you think obeying the commandment to organize the United Firm would help prepare the Saints to inherit a place in the celestial kingdom?

 **3.** In your scripture study journal, list as many of the Lord’s commandments as you can in one minute. Then choose one of the commandments you listed and write a few sentences that explain how obeying that commandment can help prepare you for a place in the celestial kingdom.



As you read the following statement by Elder Dallin H. Oaks of the Quorum of the Twelve Apostles, consider why it is important to understand the Lord’s purpose for giving us commandments: “The final judgment is not just an evaluation of a sum total of good and evil acts—what we have *done*. It is an acknowledgment of the final



effect of our acts and thoughts—what we have *become*. It is not enough for anyone just to go through the motions. The commandments, ordinances, and covenants of the gospel are not a list of deposits required to be made in some heavenly account. The gospel of Jesus Christ is a plan that shows us how to become what our Heavenly Father desires us to become” (“The Challenge to Become,” *Ensign*, Nov. 2000, 32).

 **4.** Answer the following question in your scripture study journal: How will your understanding of the Lord’s purpose for giving us commandments help you obey Him with greater faithfulness?

Read Doctrine and Covenants 78:8–9, looking for the names of those whom the Lord appointed to organize the United Firm.

Notice in verse 9 that the Lord commanded these men to sit in council with the Saints in Zion, meaning the Church members in Independence, Missouri. In order to obey this commandment, Joseph Smith, Newel K. Whitney, and Sidney Rigdon would have to travel almost 1,000 miles (each way) between Hiram, Ohio, and Independence, Missouri. In April 1832, less than one month after this revelation was received, the three men obeyed the commandment and traveled to Missouri.

What does their response teach you about faith in and obedience to the Lord’s commandments?

Shortly after their arrival in Missouri, the three held a council in which they organized the United Firm in accordance with the direction in the revelation. Profits from the United Firm’s business operations were placed into the storehouse to care for the poor and to fund other financial needs of the Church.

In Doctrine and Covenants 78:10–16, the Lord emphasized the importance of the United Firm. He explained that if the Saints followed His instructions, they would have His assistance in accomplishing His commandments and the Church would be able to stand independent from all other earthly entities.

## Doctrine and Covenants 78:17–22

*The Lord describes the blessings available to those who keep His commandments*

Think of some gifts or blessings you received when you were younger that you appreciate even more now that you are older. Why do you appreciate these gifts or blessings more now? Think about how this can relate to the blessings that our Heavenly Father has prepared for us.

Read Doctrine and Covenants 78:17–18, and identify how the Saints were like little children. You might want to consider substituting your name in place of the pronouns *ye*, *you*, and *yours* to help personalize these verses to you.)



Ponder how knowing that the Lord “will lead [us] along” (D&C 78:18) can help us be of good cheer, even when we are not able to understand or bear all things.

Read Doctrine and Covenants 78:19, looking for the counsel the Lord gave to the Saints. (Doctrine and Covenants 78:19 is a scripture mastery verse. You may want to mark it in a distinctive way.)

Complete the following principle based on what you learned from verse 19: **If we \_\_\_\_\_, the Lord will multiply our blessings.**

 **5.** Answer the following questions in your scripture study journal:

- How can you more fully receive all things with thankfulness?
- How can choosing to receive all things with thankfulness help you to be of good cheer?

## Scripture Mastery—D&C 78:19

 **6.** In your scripture study journal, write a two-minute talk based on Doctrine and Covenants 78:19. In your talk, be sure to include the following: (1) background information that relates to this passage, (2) the principle it teaches, and (3) a personal experience that illustrates the truth that this passage teaches. Once your talk is completed, share it with a family member or friend. Your home-study teacher may also invite you to share your talk with your class.

Read Doctrine and Covenants 78:20–22, looking for the counsel the Lord gave.



## Doctrine and Covenants 79–80

*Jared Carter, Stephen Burnett, and Eden Smith are called to serve missions*

In the revelations recorded in Doctrine and Covenants 79 and 80, the Lord called three men to serve as missionaries. Read each section, looking for principles that apply to missionary work. Ponder how you can apply the principles you found to more effectively share the gospel with someone you know.



7. Write the following at the bottom of today's assignments in your scripture study journal:

*I have studied Doctrine and Covenants 78–80 and completed this lesson on (date).*

*Additional questions, thoughts, and insights I would like to share with my teacher:*

### UNIT 17: DAY 3

# Doctrine and Covenants 81

## Introduction

On March 8, 1832, the Lord called Jesse Gause and Sidney Rigdon to serve as Joseph Smith's counselors. One week later, on March 15, 1832, the Lord gave the revelation recorded in Doctrine and Covenants 81. In this revelation He described the role of counselors in the First Presidency and promised eternal life to Jesse Gause if he remained faithful to the end. Jesse Gause did not remain faithful, and the Lord transferred the call to serve as a counselor in the First Presidency to Frederick G. Williams, whose name was subsequently attached to this revelation.

## Doctrine and Covenants 81

*The Lord describes the role of counselors in the First Presidency*

Why does the Lord give us callings in His Church? What are the blessings of faithfully fulfilling a calling? What if someone chooses not to faithfully fulfill his or her calling? Although a Church leader may receive inspiration to call a member of the Church to a certain position, it is up to the individual who receives the call to faithfully respond to it.

Read the section introduction to Doctrine and Covenants 81, looking for who was initially called to serve as a counselor in the Presidency of the High Priesthood (the First Presidency) and what happened to him.

Jesse Gause was called to serve as a counselor in the Presidency of the High Priesthood (the First Presidency) in March 1832. Six months later, on August 1, 1832, he left to serve a mission with Zebedee Coltrin. Jesse visited with his wife and tried to convince her of the truthfulness of the restored Church, but she refused to join. A short time later, Jesse's missionary companion, Zebedee, became very ill and had to return to Kirtland, Ohio. Left alone, Jesse did not complete his mission and did not stay faithful in the Church. He was excommunicated in December 1832.

According to the section introduction to Doctrine and Covenants 81, whom did the Lord call to replace Jesse? \_\_\_\_\_

You may want to mark the following phrase found in the section introduction: "The revelation . . . should be regarded as a step toward the formal organization of the First Presidency." The Lord did not reveal the complete organization of His Church to the Prophet all at once. Rather, He revealed different parts of the organization as the need arose and as the Saints were ready to receive them. In March 1832, the Lord revealed the time had come to organize the Presidency of the High Priesthood.

In the revelation recorded in Doctrine and Covenants 81, the Lord explained one important role of the First Presidency. Read Doctrine and Covenants 81:1–2, and mark the words that teach that **the Presidency of the High Priesthood holds the keys of God's kingdom on the earth**.

Remember that priesthood keys are the authority to preside over the Church and direct the use of priesthood power. Later, the First Presidency would be organized. The keys of the kingdom are always held by the First Presidency, presided over by the President of the Church.

President Joseph Fielding Smith explained what the keys of the kingdom enable the First Presidency to do in our day: "These keys are the right of presidency; they are the power and authority to govern and direct all of the Lord's affairs on earth. Those who hold them have power to govern and control the manner in which all others may serve in the priesthood" ("Eternal Keys and the Right to Preside," *Ensign*, July 1972, 87).



The First Presidency, 2013

One way the First Presidency directs and governs the Church is through their teachings.

 **1.** In your scripture study journal, write an example of how you have been blessed by the teachings of the First Presidency.

Read Doctrine and Covenants 81:3, looking for what the Lord told Frederick G. Williams to do as a counselor in the First Presidency.

 **2.** Write the heading *A Counselor in the First Presidency* in your scripture study journal. Under this heading, list the responsibilities you identified in verse 3. In addition, write what you think it means for a counselor to be “faithful in counsel” to his or her president.



To help you better understand what it means for a counselor to be “faithful in counsel” to the president, consider what President Gordon B. Hinckley taught about how a counselor should counsel with the president.

“[A counselor] is *an assistant to his president*. . . .

“As an assistant, the counselor is not the president. He does not assume responsibility and move out ahead of his president.

“In presidency meetings, each counselor is free to speak his mind on all issues that come before the presidency. However, it is the prerogative of the president to make the decision, and it is the duty of the counselors to back him in that decision. His decision then becomes their decision, regardless of their previous ideas” (“In . . . Counsellors There Is Safety,” *Ensign*, Nov. 1990, 49).

 **3.** Answer the following questions in your scripture study journal:

- a. How might understanding the duties of a counselor help someone who is serving as a counselor in any presidency of the Church?
- b. Why should counselors in a presidency support and strengthen the president?
- c. What could you do to effectively serve in a presidency if or when you have that opportunity?

The Lord gave a powerful promise to Frederick G. Williams if he would be faithful in his calling. Read Doctrine and Covenants 81:4, and find the promise.

The phrase “promote the glory of . . . your Lord” in this context implies that by being faithful in our callings, we can help lead people to honor and worship the Lord. This promise applies to us as well. You may want to write the following principle in the margin of your scriptures: ***If we are faithful in our callings, we can do a great good for others and promote the glory of God.***

 **4.** Answer the following questions in your scripture study journal:

- a. How might serving faithfully in our Church callings help us do a great good for other people?
- b. When have you seen members of the Church do great good for others because they were faithful in their callings? Write about what you have observed.
- c. How might serving faithfully in your Church callings help promote the glory of God?

Read Doctrine and Covenants 81:5, looking for additional counsel the Lord gave to Frederick G. Williams.

Based on what the Lord told Frederick in verse 5, what can we learn about being faithful in our Church callings or being faithful members of the Church?



The following statement from Elder Marvin J. Ashton of the Quorum of the Twelve Apostles can help you understand the Lord’s counsel: “In Doctrine and Covenants 81:5, the verse might be interpreted as the Lord’s urging

Frederick G. Williams to provide strength to the weak ('succor the weak'), provide encouragement to those who are exhausted or discouraged ('lift up the hands which hang down'), and to give courage and strength to those with feeble knees and fearful hearts" ("Strengthen the Feeble Knees," *Ensign*, Nov. 1991, 70).



 **5.** In your scripture study journal, write about an experience when you have been lifted or strengthened by someone else. Then list at least three things you could do to "succor the weak, lift up the hands which hang down, and strengthen the feeble knees" of others. Write a goal to help someone else this week by doing one of the items on your list.

Read Doctrine and Covenants 81:6–7, looking for the blessings the Lord promised Frederick G. Williams if he would be faithful to the end.

This same promise is available to you as well. If you choose to be faithful to the Lord, which includes being faithful in your callings and helping those around you, you will also qualify for the Lord's blessings.

 **6.** Write the following at the bottom of today's assignments in your scripture study journal:

*I have studied Doctrine and Covenants 81 and completed this lesson on (date).*

*Additional questions, thoughts, and insights I would like to share with my teacher:*

## UNIT 17: DAY 4

# Doctrine and Covenants 82–83

### Introduction

The revelation found in Doctrine and Covenants 82 was received on April 26, 1832, during a council of high priests and elders of the Church in Independence, Jackson County, Missouri. In this revelation the Lord forgave the brethren of their trespasses and warned them against further sin. The Lord also instructed these brethren in Missouri on how to manage the temporal affairs of Zion. Four days later, the Prophet Joseph

Smith received the revelation recorded in Doctrine and Covenants 83, in which the Lord instructed Church leaders on how to care for widows and orphans.

### Doctrine and Covenants 82:1–7

*The Lord warns those who have received much from Him*

Think of a time when you had a disagreement with a friend or family member that was eventually resolved. How did you feel after you resolved your disagreement?

For several months, unkind feelings had developed between Sidney Rigdon in Ohio and Bishop Edward Partridge in Missouri. In April 1832, the Prophet Joseph Smith and other Church leaders traveled to Missouri in obedience to the Lord's command that they "sit in council with the Saints which are in Zion" (D&C 78:9). Upon their arrival, a council of high priests and elders of the Church was held. Between the morning and afternoon sessions of the conference, Sidney Rigdon and Edward Partridge resolved their differences. The revelation in Doctrine and Covenants 82 was received during the afternoon session.

Read Doctrine and Covenants 82:1, looking for what the Lord told Sidney Rigdon and William Partridge about resolving their differences.

Based on what you learn in verse 1, complete the following principle describing the relationship between forgiving others and receiving the Lord's forgiveness: \_\_\_\_\_ is a necessary part of receiving the Lord's forgiveness for our sins. (Compare to D&C 64:9–11.)

Although the Lord extended His forgiveness at this time, He also gave them a warning. Read Doctrine and Covenants 82:2, looking for the warning the Lord gave these Saints.

As Church members moved from Ohio to Missouri, many of them failed to obey the counsel of Church leaders, and some refused to live the law of consecration. As a result, some of these Church members were guilty of jealousy, covetousness, and a neglect of duty.

Read Doctrine and Covenants 82:3–4, looking for a reason why the Lord's judgments would come upon those who continued in sin.

 **1.** In your scripture study journal, write a principle the Lord taught in Doctrine and Covenants 82:3. Then answer the following question: Why you think those who have received more from the Lord would also have more required of them?

 **2.** In your scripture study journal, list as many of the blessings you have received from the Lord as you can think of in two minutes. Include blessings that have come to you as a member of the Church. Then choose one of the blessings you wrote down and answer the following questions:

- a. What do you think the Lord expects you to do with this blessing? (For example, if you recognize that you have been blessed by having the truths of the gospel in your life, one of the expectations may be that you share these truths with others.)
- b. What can you start doing to fulfill that expectation?

In Doctrine and Covenants 82:5–6, the Lord warned the Saints that the dominion and power of Satan over the earth was increasing. Read Doctrine and Covenants 82:7, looking for an additional warning the Lord gave these Church members about sin. From this verse we learn that it is important to completely forsake our sins because if we sin again after repenting, our former sins return.

 **3.** In your scripture study journal, write why you think our former sins return when we intentionally sin after we have sought the Lord's forgiveness.

## Doctrine and Covenants 82:8–24

*The Lord commands nine men to form a firm to manage the temporal affairs of the Church*

Think of a situation when you or someone you know needed to be assured that God keeps His promises. During the council of high priests and elders in Missouri, the Lord gave a reassuring promise to those who obey His commandments. As you continue your study of Doctrine and Covenants 82, look for principles that could offer assurance to someone in a situation like the one you thought of above.

Read Doctrine and Covenants 82:8–9, looking for what the Lord said He was going to give the Saints during this council. You may want to mark the Lord's reasons for giving them this new commandment. Ponder how these reasons could apply to every commandment the Lord gives us.

 **4.** Read Doctrine and Covenants 82:10 (a scripture mastery passage), looking for a principle that can give us confidence as we strive to obey the Lord's commandments. (You may want to mark this scripture in a distinctive way to make it easy to find later.) Then write the following assignments in your scripture study journal:

- a. Complete the following principle: *If we obey the Lord, He is . . .*
- b. Ponder experiences you have had that have shown you that this principle is true, then write about one of those experiences.

As you learned in Doctrine and Covenants 78, the Lord commanded Church leaders in Kirtland, Ohio, to form a firm, a Church business association known as the United Firm. Resources from the business operations of the firm were to be used to care for the poor and provide funding for Church needs. As recorded in Doctrine and Covenants 82:11, 15–17, the Lord commanded Church leaders in Missouri to join the United Firm by covenant.

Read Doctrine and Covenants 82:12, looking for what the United Firm's purpose was. As you read, it may help you to recall that one of the duties of the bishop is to assist with the temporal needs of Church members.



Read Doctrine and Covenants 82:14, 18–19, looking for words and phrases that further explain why the Lord commanded Church leaders to form the United Firm. You may want to mark the words or phrases you find.

As recorded in Doctrine and Covenants 82:20–24, the Lord ended this revelation by warning Church leaders to be faithful to the covenant they would make as members of the United Firm.

## Scripture Mastery—Doctrine and Covenants 82:10

Doctrine and Covenants 82:10 is a scripture mastery passage. Try to memorize it by repeating it several times. After you have memorized it, recite it to a family member or friend and share what you have experienced that has confirmed to you that the Lord does keep His promises to us when we do what He asks.

 **5.** In your scripture study journal, write about what you shared with your family member or friend.



## Doctrine and Covenants 83

*The Lord reveals how to care for widows and orphans*

Four days after receiving the revelation in Doctrine and Covenants 82, the Prophet Joseph Smith received a revelation about how to further care for the temporal needs of the Saints. Read Doctrine and Covenants 83:1, looking for whose needs were addressed by this revelation.

To understand this section, recall that many of the Saints were living the law of consecration and had received an “inheritance,” or property from the Church. In this revelation the Lord revealed what should happen to a family’s inheritance if a husband or father died.

Read Doctrine and Covenants 83:2–3, looking for the Lord’s instructions about caring for women who had lost their husbands. (It may help to realize that at the time, most women relied on their husbands for their temporal support. “To have fellowship in the church” meant that, since the wife’s provider was gone, the Church would look after her needs.) Then read Doctrine and Covenants 83:4–6, looking for how the Church is to care for orphans and for widows.



 **6.** In your scripture study journal, write what Doctrine and Covenants 83 teaches you about how the Lord feels about widows, orphans, and all those in need?

 **7.** Write the following at the bottom of today’s assignments in your scripture study journal:

*I have studied Doctrine and Covenants 82–83 and completed this lesson on (date).*

*Additional questions, thoughts, and insights I would like to share with my teacher:*

## UNIT 18: DAY 1

# Doctrine and Covenants 84:1–42

## Introduction

In September 1832, missionaries returned to Kirtland, Ohio, after preaching the gospel in the eastern United States. During their joyful reunion, the Prophet Joseph Smith received the revelation recorded in Doctrine and Covenants 84. He received the revelation over the course of two days: September 22 and 23. (There is some historical evidence that verses 1–41 were received on September 22 and that verses 42–120 were received on September 23.) Your study of Doctrine and Covenants 84 is divided into two lessons. This first lesson focuses on the Lord’s instructions about the priesthood and how the priesthood can prepare us to receive all that Heavenly Father has.

## Doctrine and Covenants 84:1–30

*The Lord declares that a temple will be built and explains the purposes of the priesthood*

Think of a temple you have visited or would like to visit. How would you explain to a friend of another faith the differences between the temple and another building in the community?

Read Doctrine and Covenants 84:2–5, and mark words or phrases the Lord used to help the Saints understand the importance of building a temple.



These verses repeat the prophecy that the city New Jerusalem and a temple will be built in Jackson County, Missouri. Later, however, in 1841 the Lord told the Saints that they were not required at that time to build

the city or the temple in Missouri because of severe persecution from the enemies of the Church (see D&C 124:49). The phrase “this generation” in Doctrine and Covenants 84:5 refers to the prophecy concerning the building of New Jerusalem and the temple—that it will still occur and will be fulfilled at some time in the future (see Moses 7:62).

Doctrine and Covenants 84 provides an opportunity to learn about the important blessings you can receive in the temple. Before continuing your study of this section, it will be helpful to review some key terms related to the principles the Lord taught in this revelation. In the following chart, carefully read the doctrinal definitions on the right. Match each one with the appropriate term on the left.

Term	Definition
___ 1. Covenant	a. The higher or greater priesthood, which administers in spiritual things b. The preparatory priesthood, which holds the keys of the ministering of angels and of the gospel of repentance and baptism c. A sacred agreement between God and man d. A sacred act essential to exaltation and accompanied by covenants
___ 2. Saving ordinance	
___ 3. Melchizedek Priesthood	
___ 4. Aaronic Priesthood	

(See the answers for the matching activity at the end of this lesson.)

Read the following list of priesthood ordinances and blessings, and put a check mark in the column next to those that would be considered saving ordinances:

	Baptism
	Confirmation
	The naming and blessing of children
	Conferral of the Melchizedek Priesthood (for men)

	Administering to the sick
	The temple endowment
	The marriage sealing

Each of the items in the list, except for the naming and blessing of children and administering to the sick, is a saving ordinance. The priesthood ordinances of naming and blessing children and administering to the sick bless the lives of those who receive them, but they are not essential for salvation.

In Doctrine and Covenants 84:6–19, we learn that Moses held the Melchizedek Priesthood, or the “greater priesthood” (D&C 84:19). He could trace his priesthood authority back to God. As a righteous priesthood holder, Moses’s desire was to help other people draw nearer to God through the saving ordinances of the priesthood.

Read Doctrine and Covenants 84:19–22, looking for the blessings we can receive through the Melchizedek Priesthood.

Notice in verse 20 that **in the ordinances of the Melchizedek Priesthood, the power of godliness is manifest.** Except for baptism, each of the ordinances in the preceding chart must be administered by the authority of the Melchizedek Priesthood. How do you feel the power of godliness is manifest in these ordinances? \_\_\_\_\_

Two of the saving ordinances of the Melchizedek Priesthood—the temple endowment and the marriage sealing—can only be received in the temple. According to Doctrine and Covenants 84:22, why is it important that we receive the saving ordinances of the Melchizedek Priesthood? \_\_\_\_\_

Verse 22 can refer to seeing God in this life, but ultimately it refers to our ability to dwell in Heavenly Father’s presence for eternity. You may want to write the following principle in the margin of your scriptures next to verses 21–22: **To become like God and dwell in His presence, we must receive the saving ordinances of the Melchizedek Priesthood.**



1. In your scripture study journal, write about how the principles you have learned in your study of Doctrine and Covenants 84 so far have helped you understand the importance of the priesthood and the importance of temples.



As you read the following statement by Elder Russell M. Nelson of the Quorum of the Twelve Apostles, think of why it is important for you to receive all the saving ordinances of the gospel—including those available only in the temple: “The temple

is the object of every activity, every lesson, every progressive step in the Church. All of our efforts in proclaiming the gospel, perfecting the Saints, and redeeming the dead lead to the holy temple. Ordinances of the temple are absolutely crucial. We cannot return to God’s glory without them” (“Prepare for the Blessings of the Temple,” *Ensign*, Oct. 2010, 41).

Read Doctrine and Covenants 84:23 to discover something Moses sought to do. Remember that the word *sanctify* means to cleanse and make holy. Next, read Doctrine and Covenants 84:24–25, and identify how the children of Israel responded to Moses’s efforts to teach them. What were the consequences of their actions?

As you discovered, the children of Israel lost the opportunity to receive the saving ordinances of the Melchizedek Priesthood. However, the Lord did not stop trying to help them progress. He allowed the lesser priesthood, or the Aaronic Priesthood, to continue with them. Read Doctrine and Covenants 84:26–28, and identify how the Lord continued to bless the children of Israel. As you study, you may want to mark the blessings we can receive through the Aaronic Priesthood.

It may be helpful to understand that in verse 28 the phrase “he was baptized while yet in his childhood” refers to John’s baptism at age eight. The phrase “ordained by the angel of God at the time he was eight days old” means that John was set apart “to make straight the way of the Lord [and] to prepare [the people] for the coming of the Lord.” It does not refer to the time when John received the Aaronic Priesthood. John’s ordination to the Aaronic priesthood came after his baptism. (See Bruce R. McConkie, *The Mortal Messiah: From Bethlehem to Calvary*, 4 vols. [1979–81], 1:384–85.)





The Aaronic Priesthood prepares us to receive the ordinances and blessings of the Melchizedek Priesthood. For example, after baptism, which is an ordinance of the Aaronic Priesthood, we receive the gift of the Holy Ghost through the authority of the Melchizedek Priesthood. As we partake of the sacrament, an ordinance of the Aaronic Priesthood, we renew covenants that help sanctify us and receive the constant companionship of the Holy Ghost and help us prepare to receive ordinances and make covenants in the temple. A young man's service as an Aaronic Priesthood holder prepares him to receive the Melchizedek Priesthood.

 **2.** Answer the following question in your scripture study journal: What can you do now to prepare to receive all of the saving ordinances of the gospel?

## Doctrine and Covenants 84:31–42

### *The Lord teaches the oath and covenant of the priesthood*

As you study about the oath and covenant of the priesthood, keep in mind that “an oath is a sworn affirmation to be true and faithful to one’s promises. A covenant is a solemn promise between two parties. The Aaronic Priesthood is received by covenant alone. Melchizedek Priesthood holders receive the priesthood by unspoken oath as well as by covenant. As priesthood holders are faithful and magnify their callings as God directs, he blesses them. Those who are faithful to the end and do all he asks of them will receive all that the Father has (D&C 84:33–39)” (Guide to the Scriptures, “Oath and Covenant of the Priesthood”; scriptures.lds.org). The “covenant” is man’s agreement with God, and the “oath” is God’s solemn promises to those who keep the covenant.

Doctrine and Covenants 84:31–32 teaches that priesthood holders in the last days (“the sons of Moses and of Aaron”) will labor in the house of the Lord (the temple) and be filled with the glory of the Lord. Doctrine and Covenants 84:33–44 contains the oath and covenant of the priesthood. From it we learn this principle: **If those who receive the priesthood magnify their callings, God will sanctify them and give them all that He has.**

 **3.** Write the following in your scripture study journal: *The Lord promises to . . .* Then study Doctrine and Covenants 84:33–44, and identify at least five promises the Lord gives to those who enter into the oath and covenant of the priesthood. (You can check your answers with those at the end of this lesson.)

President Gordon B. Hinckley taught the following about priesthood holders magnifying their calling:



“We magnify our priesthood and enlarge our calling when we serve with diligence and enthusiasm in those responsibilities to which we are called by proper authority. . . .

“We magnify our calling, we enlarge the potential of our priesthood when we reach out to those in distress and give strength to those who falter. . . .

“We magnify our calling when we walk with honesty and integrity” (“Magnify Your Calling,” *Ensign*, May 1989, 48–49).

All Church members who receive callings and are set apart receive blessings through the Melchizedek Priesthood to magnify their Church callings. President Thomas S. Monson gave a simple explanation about how each of us can magnify our callings: “How does one magnify a calling? Simply by performing the service that pertains to it” (“Priesthood Power,” *Ensign*, Nov. 1999, 51).



 **4.** In your scripture study journal, answer the following questions about what it means to magnify a calling:

- a. How does a priesthood holder magnify his calling in the priesthood?
- b. How have you been blessed because someone has magnified his or her calling?

The duty of all priesthood holders is to prepare themselves and others to receive the saving ordinances of the gospel and live the associated covenants so they can receive eternal life with Heavenly Father.





5. Write the following at the bottom of today's assignments in your scripture study journal:

*I have studied Doctrine and Covenants 84:1–42 and completed this lesson on (date).*

*Additional questions, thoughts, and insights I would like to share with my teacher:*

Answers for the matching activity: (1) c, (2) d, (3) a, (4) b.

Possible answers for assignment 3, identifying the Lord's promises to those who enter into the oath and covenant of the priesthood (from D&C 84:33–44): The Lord will (1) sanctify us by the Spirit (see verse 33); (2) renew our bodies (see verse 33); (3) count us among the seed of Abraham—in other words, give us the blessings promised to Abraham and his posterity (see verse 34); (4) make us His elect, or chosen (see verse 34); (5) give us all that the Father has (see verse 38); and (6) give His angels charge over us (see verse 42).

## UNIT 18: DAY 2

# Doctrine and Covenants 84:43–120

### Introduction

On September 22 and 23, 1832, the Prophet Joseph Smith received the revelation recorded in Doctrine and Covenants 84. In this revelation the Lord taught the Saints the importance of giving heed to the word of God and chastened them for treating the Book of Mormon and former commandments lightly. In addition, He emphasized the commission of Apostles and other priesthood holders to preach the gospel throughout the world, and He explained how this work was to be accomplished.

### Doctrine and Covenants 84:43–61

*The Lord teaches the importance of giving heed to the word of God*

Consider your efforts to study the scriptures daily. How well are you doing in accomplishing this goal?



1. Sometimes it is difficult to maintain a habit of daily scripture study. In your scripture study journal, list some challenges you face in trying to study the scriptures each day. Write about a time when you chose to study the scriptures even when it was difficult. How were you blessed for doing so?

As you continue your study of Doctrine and Covenants 84, you will learn truths that can inspire you to continue your efforts to study the scriptures daily. Read Doctrine and Covenants 84:43–44, and identify words and phrases that teach the importance of studying and applying the word of the Lord. You may want to mark what you find.

Study Doctrine and Covenants 84:45–46.

These verses help us understand that **if we give diligent heed**

**to the word of God, then we will be enlightened through the Spirit of Christ.**

Note the phrase “the Spirit of Jesus Christ” in verse 45. Another phrase that means the same thing is “the Light of Christ.” The Light of Christ is “an influence for good in the lives of all people. . . . In the scriptures, the Light of Christ is sometimes called the Spirit of the Lord, the Spirit of God, the Spirit of Christ, or the Light of Life.

“The Light of Christ should not be confused with the Holy Ghost. It is not a personage, as the Holy Ghost is. Its influence leads people to find the true gospel, be baptized, and receive the gift of the Holy Ghost” (*True to the Faith: A Gospel Reference* [2004], 96).



President Boyd K. Packer of the Quorum of the Twelve Apostles taught that the Light of Christ is within each person, and “regardless of whether this inner light, this knowledge of right and wrong, is called the Light of Christ, moral sense, or conscience, it can direct us to moderate our actions—unless, that is, we subdue it or silence it” (“The Light of Christ,” *Ensign* or *Liahona*, Apr. 2005, 8–9).

Read Doctrine and Covenants 84:47, and complete the following principle based on what you discover: **If we hearken to the Spirit, we will** \_\_\_\_\_

\_\_\_\_\_

### Study the Scriptures Daily

Daily scripture study will increase your faith in Heavenly Father and Jesus Christ. It will also help you understand the plan of salvation. President Howard W. Hunter taught, “It is certain that one who studies the scriptures every day accomplishes far more than one who devotes considerable time one day and then lets days go by before continuing” (“Reading the Scriptures,” *Ensign*, Nov. 1979, 64).

As you read Doctrine and Covenants 84:48, notice what the Father will do as we come unto Him.

In addition to having the Light of Christ, individuals can receive the companionship of the Holy Ghost after they enter into the covenant of baptism. Through the gift of the Holy Ghost, they can receive additional light and be guided back into the presence of the Father to receive eternal life.

Think about a time when you tried to walk in complete physical darkness. Is there a difference in the way you walk when it is completely dark compared to when there is light? The scriptures often refer to darkness to symbolize a spiritual condition. Read Doctrine and Covenants 84:49–53, and identify who the Lord said is in darkness and why they are in that condition.



**2.** Answer the following question in your scripture study journal: How is living under the bondage of sin like being in darkness?

Ponder what you feel you need to do better to receive His voice and avoid the bondage of sin.

In addition to saying that the world was in darkness, the Lord said that the minds of Church members had been darkened. Read Doctrine and Covenants 84:54–56, looking for two reasons why their minds had become darkened.

To treat something lightly means to ignore it or to treat it disrespectfully or carelessly. How can a person’s mind be darkened by treating a sacred thing lightly? In Doctrine and Covenants 84:54, the phrase “you have treated lightly the things you have received” refers specifically to the Saints not doing what was written in the Book of Mormon and the former commandments.

Read Doctrine and Covenants 84:57–58 to discover what the Saints had been treating lightly and what they needed to do to avoid a scourge and a judgment. (The word *scourge* in these verses refers to punishment from God or a trial.)

Notice that the Saints had neglected the Book of Mormon as well as “the former commandments” the Lord had given them. Elder Dallin H. Oaks of the Quorum of the Twelve Apostles said: “These former commandments must have been the Lord’s prior revelations, as contained in the Bible (the Old and New Testaments) and in those modern revelations already given to the Saints (see *History of the Church*, 1:318, 320)” (“Another Testament of Jesus Christ,” *Ensign*, Mar. 1994, 63).

From Doctrine and Covenants 84:57–58, we learn the following principle: **If we treat the word of God lightly, our minds will be darkened and we will be brought under condemnation.**

Read the following statements by President Ezra Taft Benson:



“Do eternal consequences rest upon our response to [the Book of Mormon]? Yes, either to our blessing or to our condemnation.

“Every Latter-day Saint should make the study of this book a lifetime pursuit. Otherwise, he is placing his soul in jeopardy and neglecting that which could give spiritual and intellectual unity to his whole life. There is a difference between a convert who is built on the rock of Christ through the Book of Mormon and stays hold of that iron rod, and one who does not” (“The Book of Mormon Is the Word of God,” *Ensign*, May 1975, 65; see also “The Book of Mormon Is the Word of God,” *Ensign*, Jan. 1988, 5).

“If the early Saints were rebuked for treating the Book of Mormon lightly, are we under any less condemnation if we do the same? . . .

“Let us not remain under condemnation, with its scourge and judgment, by treating lightly this great and marvelous gift the Lord has given to us. Rather, let us win the promises associated with treasuring it up in our hearts” (“The Book of Mormon—Keystone of Our Religion,” *Ensign*, Nov. 1986, 4–5, 7).



**3.** Answer the following questions in your scripture study journal:

- How would you describe your treatment of the Book of Mormon?
- What can you do to make your study of it a lifetime pursuit?
- What will you do to more diligently study the scriptures and live the truths you learn in them?

## Doctrine and Covenants 84:62–120

*The Lord gives instructions to those who are called to preach His gospel*

Consider the billions of people who live on the earth. Each person needs to have the opportunity to learn the gospel. However, it is not possible for the First Presidency and the Quorum of the Twelve Apostles, who have the charge to declare the gospel to all nations, to teach everyone.

Read Doctrine and Covenants 84:62, and identify the direction the Lord gave to those who have the responsibility to preach the gospel.

Notice that because Church leaders cannot go everywhere to preach the gospel, they are to send others to help them. Doctrine and Covenants 84:62 can help us understand that **all Latter-day Saints have a responsibility to take the gospel to the whole world.**

President Spencer W. Kimball said:



“The scriptures are abundantly clear in stating that all members of the Church are responsible to do missionary work: ‘It becometh every man who hath been warned to warn his neighbor.’ (D&C 88:81.)

“The prophets of this dispensation also have clearly taught the concept that missionary service is the responsibility of all members. President David O. McKay taught the principle with the challenging words, ‘Every member a missionary!’ (See *Conference Report*, April 1959, p. 122.)” (“It Becometh Every Man,” *Ensign*, Oct. 1977, 3).

Read Doctrine and Covenants 84:64–75, and ponder why it is important for the gospel to be preached to the entire world.

 **4.** Answer the following question in your scripture study journal: Based on what you read in Doctrine and Covenants 84:64–75, how would you summarize the importance of teaching others the gospel of Jesus Christ? Then complete the following statement: *I will fulfill my responsibility to share the gospel by . . .*

In the following list, underline any fears that might cause you to be reluctant to serve the Lord as a full-time missionary: fear of leaving home, family, and friends; fear of missing school and work opportunities; fear of not being able to pay for a mission; fear of speaking to others about the gospel; and fear of learning a new language.

The Lord reassured those who may be reluctant or have fears about serving Him as a missionary. Read Doctrine and Covenants 84:80, 85, 87–88, looking for the responsibilities and blessings of missionary service. Fill in the chart with what you find:

Responsibilities of Missionary Service	Blessings of Missionary Service

The verses you have studied affirm that **as we share the gospel, the Lord will be with us, will protect us, and will strengthen us.**

 **5.** In your scripture study journal, explain how the promises stated in Doctrine and Covenants 84:80, 85, 88 might influence your desire and ability to share the gospel.

In Doctrine and Covenants 84:89–97, the Lord affirmed that those who accept His missionaries also accept Him and will be blessed. He also taught that those who reject His servants and His word will forfeit blessings and be cursed.

Read Doctrine and Covenants 84:98–102. These verses contain the words of a song of joy and praise associated with the redemption of Zion. The redemption of Zion refers to the condition God’s covenant people will enjoy when they choose to come unto Him and receive all of the ordinances and blessings of the gospel.



Why do you think the Lord calls missionaries to serve in companionships?

Think of some other callings in the Church in which members serve with one or more other persons. Read Doctrine and Covenants 84:106, 109–10, and identify what the Lord instructed Church members to do to strengthen one another.

Doctrine and Covenants 84:106 teaches that **those who are strong in the Spirit are to edify those who may be weak.**



**6.** Answer the following questions in your scripture study journal:

- a. When have you been uplifted by working with someone who is strong in the Spirit?
- b. What can you do to seek out ways to encourage and strengthen others?



**7.** Write the following at the bottom of today's assignments in your scripture study journal:

*I have studied Doctrine and Covenants 84:43–120 and completed this lesson on (date).*

*Additional questions, thoughts, and insights I would like to share with my teacher:*

## UNIT 18: DAY 3

# Doctrine and Covenants 85–86

### Introduction

Doctrine and Covenants 85 is a portion of an inspired letter the Prophet Joseph Smith sent to William W. Phelps on November 27, 1832. In this letter the Prophet explained that the Lord desired an accurate record to be kept of those who were living the law of consecration in Missouri. Later, on December 6, 1832, Joseph Smith received the revelation recorded in Doctrine and Covenants 86 as he was working on the inspired revisions of the Bible. This revelation provided further explanation of the parable of the wheat and the tares and the role of the priesthood in helping the Lord gather the righteous in the last days.

## Doctrine and Covenants 85

*The Lord's clerk is to keep a record of the people of God*

Imagine you are on a sports team that has the potential to be really great. After a few days of playing with this team, you observe that one team member is a selfish player, some team members won't play their positions properly, and others ignore the coach. Why might it be difficult for your team to win? What might need to be changed so the team can play better?

A similar situation began to arise in 1832 as more and more Church members arrived in Missouri. Many of the Saints in Missouri lived in harmony with the laws the Lord had set forth for building Zion. However, a number of Church members disobeyed the Lord's commandments and traveled to Missouri without obtaining a certificate from their leaders (which was required by the laws the Lord had set forth in D&C 72:17–18, 25). A certificate was a piece of paper signed by the Bishop of the Church or the three presiding Elders of the Church, stating that the person was worthy and in good standing and able to receive a stewardship. Although all Church members in Missouri were commanded to consecrate their property to the Church, some arrived without any resources to consecrate, which increased the challenges the people faced. At least one member who had consecrated property demanded it back upon leaving the Church. Others in Missouri refused to consecrate their properties to the Church.



**1.** Answer the following questions in your scripture study journal:

- a. How is this behavior by some Church members like being an unproductive member of a team?
- b. Why might it have been difficult to establish the city of Zion under these circumstances?

Read the section introduction to Doctrine and Covenants 85 to understand how the Prophet Joseph Smith responded to these difficulties in Missouri.





John Whitmer

Joseph Smith's letter provided instructions for the Lord's clerk, John Whitmer, who lived in Missouri. Read Doctrine and Covenants 85:1–2, looking for what the Lord instructed the clerk of the Church in Missouri to do. (As you study these verses, it may help to know that apostates are those who apostatize, or turn away from the Church and deny the faith.)

Read Doctrine and Covenants 85:3–5, looking for the reasons why some of the people were not to have their names written in the records of the Church. In verse 3 the phrase “those who receive not their inheritance by consecration” refers to Church members who refused to live the law of consecration as the Lord had commanded.

Just as records were kept in the early days of the Church, records are also kept in our day to preserve a record of the names of the faithful, as well as an account of their works. One principle we learn from the Prophet's letter is **if we live the laws of God, our names will be written upon the records of the Church as faithful members.**

 **2.** In your scripture study journal, write about the things you must do to have your name recorded as a faithful member of the Church. (After you finish this assignment, compare what you wrote with the answers identified at the end of this lesson.)

The reference to the “one mighty and strong” (D&C 85:7) who is to set in order the house of God and the reference to one who “putteth forth his hand to steady the ark” (D&C 85:8) have been used by many apostates to justify their falling away from the Church. They claim that various Presidents of the Church have lost favor with God and are rejected and that they, the apostates, are the “one mighty and strong” called by God to set things right. Such claims contradict the meaning of the scriptures. In an official statement issued in 1905, the First Presidency (Joseph F. Smith, John R. Winder, and Anthon H. Lund) discussed the circumstances that brought this revelation forth and those to whom these two phrases referred:

“It is to be observed first of all that the subject of this whole letter [the Prophet's letter to William W. Phelps], as also the part of it subsequently accepted as a revelation [D&C 85], relates to the affairs of the Church in Missouri, the gathering of the Saints to that land and obtaining their inheritances under the law of consecration and stewardship; and the Prophet deals especially with the matter of what is to become of those who fail to receive their inheritances by order or deed from the bishop. . . .

“It was while these conditions of rebellion, jealousy, pride, unbelief and hardness of heart prevailed among the brethren in Zion—Jackson county, Missouri—in all of which Bishop Partridge participated, that the words of the revelation taken from the letter to William W. Phelps, of the 27th of November, 1832, were written. The ‘man who was called and appointed of God’ to ‘divide unto the Saints their inheritance’—Edward Partridge—was at that time out of order, neglecting his own duty, and putting ‘forth his hand to steady the ark’; hence, he was warned of the judgment of God impending, and the prediction was made that another, ‘one mighty and strong,’ would be sent of God to take his place, to have his bishopric—one having the spirit and power of that high office resting upon him, by which he would have power to ‘set in order the house of God, and arrange by lot the inheritance of the Saints’; in other words, one who would do the work that Bishop Edward Partridge had been appointed to do, but had failed to accomplish. . . .

“. . . And inasmuch as through his repentance and sacrifices and suffering, Bishop Edward Partridge undoubtedly obtained a mitigation of the threatened judgment against him of falling ‘by the shaft of death, like as a tree that is smitten by the vivid shaft of lightning,’ so the occasion for sending another to fill his station—‘one mighty and strong to set in order the house of God, and to arrange by lot the inheritances of the Saints’—may also be considered as having

passed away and the whole incident of the prophecy closed” (in James R. Clark, comp., *Messages of the First Presidency of The Church of Jesus Christ of Latter-day Saints*, 6 vols. [1965–75], 4:112, 115, 117.)

Imagine that you have plans to attend a prestigious event (for example, the wedding of a well-known person or a dinner party with someone you have always wanted to meet). How would you feel if you arrived at the event but were not allowed in because your name was not on the invitation list?

Read Doctrine and Covenants 85:9–11, looking for what the Lord said would happen to those early Saints whose names were missing from the Lord’s book of remembrance, or the book of the law of God. (Remember that these titles refer to the written account of the faith and works of the early Saints.)

Records are kept both here on the earth and in heaven. We will all have to account for our actions and our faith in living the laws of God. Ponder your attitude toward and obedience to the laws of God.

## Doctrine and Covenants 86

*The Lord further explains the parable of the wheat and the tares*



A parable is a story that uses comparison to teach a truth. Read the parable of the wheat and the tares in Matthew 13:24–30.

What do you think the wheat symbolizes? \_\_\_\_\_

---

What do you think the tares symbolize? \_\_\_\_\_

---

You can check your answers to the questions above by referring to Matthew 13:38.

 **3.** Answer the following question in your scripture study journal: Why did the man in the parable want to wait to have the tares pulled out?

Tares are a type of poisonous weed. Wheat and tares are almost identical when they sprout, but they can be identified once they are fully grown. If a reaper tried to pull out the tares before the wheat and the tares matured, much of the wheat would likely be destroyed as well.

 **4.** Read Doctrine and Covenants 86:1–6, looking for the meanings of the field, the sowers of the seed, and the enemy. Answer the following question in your scripture study journal: Based on the Lord’s explanation of the symbols, how would you summarize the meaning of the parable?

The Prophet Joseph Smith was reviewing and editing the inspired revision of the Bible when he received this revelation. According to Matthew 13:30, the Lord indicated that the tares would first be gathered and bundled together to be burned, and then the wheat would be gathered into the barn (see Joseph Smith Translation, Matthew 13:29 [in Matthew 13:30, footnote *b*]).

Read Doctrine and Covenants 86:7, looking for an insight this revelation provides about the order of the gathering. How do you think the righteous will be gathered in the last days?



Consider how missionaries teaching people about the restored gospel relates to the parable of the wheat and the tares.

# Doctrine and Covenants 87

We also can assist in the gathering of the righteous by sharing the gospel with others. People are gathered into the fold when they accept Christ and are baptized. Remembering the many ways we are blessed as members of the Lord's Church can increase our desire to share those blessings with others.

Read Doctrine and Covenants 86:8–10, and identify ways we have been blessed as members of the Lord's Church. You may want to mark what you find.

The phrase “ye are lawful heirs” in verse 9 means that members of The Church of Jesus Christ of Latter-day Saints are part of the covenant God made with Abraham, through which Abraham was promised that his descendants would enjoy the blessings of the priesthood and would share those blessings with others (see Abraham 2:9–11).

Ponder the following question: How have you been blessed through the priesthood?

While pondering the question above, you may have thought about the ordinances you have been able to receive through the priesthood, including the saving ordinances of baptism and the gift of the Holy Ghost. Read Doctrine and Covenants 86:11, and identify ways we are to help others.

The phrase “a light unto the Gentiles” means setting a righteous example for those who do not have the blessings of the gospel. Verse 11 teaches that **we can bring salvation to others by helping them receive the blessings of the priesthood.** You may want to write this principle in the margin of your scriptures.

Ponder experiences when you or someone you know set a righteous example for someone else or helped another person receive the blessings of the priesthood.

 **5.** In your scripture study journal, write about what you will do to be “a light” unto others so that they can receive the ordinances and blessings of the priesthood.

 **6.** Write the following at the bottom of today's assignments in your scripture study journal:

*I have studied Doctrine and Covenants 85–86 and completed this lesson on (date).*

*Additional questions, thoughts, and insights I would like to share with my teacher:*

*Compare the following ideas with those you wrote for scripture study journal assignment 2: To have our names recorded in the book of the law of God, or book of remembrance, we must be baptized and receive other essential ordinances, such as confirmation, priesthood ordination for men, and the endowment and sealing ordinances performed in the temple. Our faithfulness in attending Church meetings and paying tithing is also recorded in the records of the Church.*

## Introduction

Throughout 1832, the Prophet Joseph Smith and other Church members likely learned through newspaper reports of distresses sweeping the earth. Near the end of that year, the Prophet said, “Appearances of troubles among the nations became more visible this season than they had previously been since the Church began her journey out of the wilderness” (*Teachings of Presidents of the Church: Joseph Smith* [2007], 249). On December 25, 1832, Joseph Smith received the revelation now recorded in Doctrine and Covenants 87, which includes prophecies about the wars and judgments that would be poured out upon all nations in the last days.

## Doctrine and Covenants 87

*Joseph Smith prophesies that war will be poured out upon all nations.*

A prophecy is a declaration by a true prophet of a future sign or event as revealed by the Holy Ghost.

Read Doctrine and Covenants 87:1–4, and identify a prophecy given by Joseph Smith. As you study these verses, it may be helpful to know that South Carolina is a state in the southern United States.

One of the principles we can learn from Doctrine and Covenants 87:1–4 is that in our day, just as in days of old, **the Lord can reveal the future to us through His prophets.**

 **1.** Answer the following questions in your scripture study journal:

- How can knowing that the Lord reveals future events through His prophets be a blessing to the Church?
- How can knowing this be a blessing to you and your family?

Read the section introduction to Doctrine and Covenants 87. Look for the date this revelation was given and the issue Joseph Smith was reflecting on at this time.

Joseph Smith had learned about a political conflict between the state of South Carolina and the federal government of the United States over tariffs. (A tariff is

## The United States of America in 1847



a tax on imports.) Because residents of South Carolina relied more on imported manufactured products than did people in the northern states, they felt that federal tariffs were unfair and that they had been purposely levied at the expense of the South. Government leaders in South Carolina adopted an ordinance invalidating, or nullifying, the federal laws, and many South Carolinians began to prepare for military action against the federal government. The president of the United States asserted that he would maintain the laws of the United States by force.

In December 1832, newspapers throughout the United States were reporting on this conflict. It was at this time that Joseph Smith received the revelation in Doctrine and Covenants 87 prophesying that “wars . . . will shortly come to pass, beginning at the rebellion of South Carolina” (D&C 87:1). In early 1833, not long after this prophecy was given, the United States government peacefully settled the issue with the state of South Carolina. Some may have believed the crisis had passed and that the prophecy in Doctrine and Covenants 87:1–4 would not be fulfilled, but the crisis had been only temporarily halted, and South Carolina would still rebel.

 **2.** Answer the following question in your scripture study journal: How would you respond if the words of a prophet were not fulfilled in the way or during the time period you expected?

You may want to mark the cross-reference in Doctrine and Covenants 87:1 footnote *c*. Read Doctrine and Covenants 130:12–13. What did the Prophet Joseph Smith reaffirm in these verses?

Refer to the section introduction for Doctrine and Covenants 130, and identify the year Joseph Smith gave this reaffirmation of the prophecy in Doctrine and Covenants 87.

What can the Prophet Joseph Smith’s reaffirmation of the prophecy he had received 10 years earlier teach you about his faith?

The crisis between the United States government and South Carolina had been resolved 10 years earlier, in 1833. The Prophet Joseph Smith continued to maintain faith in the prophecy the Lord had revealed through him, even though many people refused to believe that a civil war would take place in the United States.





In 1861, Southern warships began firing on United States federal soldiers who were stationed at Fort Sumter, in Charleston Harbor, South Carolina. Other Southern states joined South Carolina in a civil war against the Northern states. In time, the Southern states called on Great Britain for aid. Additionally, many who had been slaves in the South joined the army of the North and fought against their former masters. The American Civil War lasted until 1865 and resulted in the death of approximately 620,000 soldiers.



Fort Sumter, in Charleston Harbor, South Carolina



3. Answer the following questions in your scripture study journal:

- a. How do these events help us know that **Joseph Smith is a true prophet?**
- b. Why is it important for you to know that Joseph Smith is a true prophet?

Every prophecy in Doctrine and Covenants 87 has been or will be fulfilled.

In addition to the events revealed in Doctrine and Covenants 87:1–4, Joseph Smith prophesied of other things that would happen. Verse 5 mentions that “the remnants who are left of the land will . . . vex the Gentiles.”

“The word *remnant* is often used in the scriptures to refer to a segment of the house of Israel (see Topical Guide, “remnant,” 419). Because the Savior made specific promises about the remnants of the Nephites and Lamanites (see 3 Nephi 20:10, 16; 21:2, 4), many have assumed that this verse refers to the Lamanite peoples who would at some point arise and ‘vex the Gentiles’ (D&C 87:5).



“President Joseph Fielding Smith wrote: ‘The history of this American continent . . . gives evidence that the Lamanites have risen up in their anger and vexed the Gentiles. This warfare may not be over. It has been the fault of people in the United

States to think that this prophetic saying has reference to the Indians in the United States, but we must remember that there are millions of the “remnant” in Mexico, Central and South America. It was during our Civil War that the Indians in Mexico rose up and gained their freedom from the tyranny which Napoleon endeavored to inflict upon them contrary to the prediction of Jacob in the Book of Mormon, that there should be no kings among the Gentiles on this land. The independence of Mexico and other nations to the south has been accomplished by the uprising of the “remnant” upon the land. However, let us not think that this prophecy has completely been fulfilled.’ (Church History and Modern Revelation, 1:363.)” (Doctrine and Covenants Student Manual, 2nd ed. [Church Educational System manual, 2001], 195).

Read Doctrine and Covenants 87:6–7, and identify other events that Joseph Smith prophesied would occur in the last days.

# Doctrine and Covenants 88:1–40

The “chastening hand” of God refers to the fact that the Lord uses His judgments to prompt His children to repent of their sins. In addition, some of the judgments described in these verses will occur as the Lord punishes the wicked for their unjust treatment of the righteous.

Read Doctrine and Covenants 87:8 to learn what the Lord directs us to do so that we will be prepared for the wars and disasters that will be upon the earth in the last days. A principle we learn from this verse is that **we are to stand in holy places and be not moved until the Lord comes**.

Holy places are locations where we can feel the presence of the Holy Ghost, which helps us draw near to Heavenly Father and Jesus Christ and to learn of Them. Standing in holy places often has more to do with *how* we live than *where* we live. If you live worthy of the constant companionship of the Holy Ghost, then you stand in a holy place. Strive to make your heart a holy place filled with the Spirit of the Lord.

 **4.** In your scripture study journal, list a few places you consider holy. Then choose one of the places you identified and describe how being in that holy place has helped you to draw near to Heavenly Father and Jesus Christ. How can you strive to make your home a holy place? If the prophet were to see where you live, your room, your locker, or places you frequent, would he view it as a holy place?

 **5.** Answer the following questions in your scripture study journal:

- What do you think it means to “stand . . . in holy places, and be not moved” (D&C 87:8)?
- How might a person be moved from holy places?
- What is something you will do to stand in holy places more faithfully and not be moved from them?

 **6.** Write the following at the bottom of today’s assignments in your scripture study journal:

*I have studied Doctrine and Covenants 87 and completed this lesson on (date).*

*Additional questions, thoughts, and insights I would like to share with my teacher:*

## Introduction

President Joseph Fielding Smith stated that Doctrine and Covenants 88 “is one of the most important revelations ever given to the Church, and several weeks could be profitably spent in discussing it” (*Church History and Modern Revelation*, 2 vols. [1953], 1:366). This is the first of three lessons that will explore Doctrine and Covenants 88. The Prophet Joseph Smith received this revelation over three days—December 27–28, 1832, and January 3, 1833. The portion of the revelation covered in this lesson includes the Lord’s teaching concerning the light of Christ and His explanation of the laws that govern His kingdoms and their inhabitants.

## Doctrine and Covenants 88:1–13

*The Lord declares that He is the light that is in all things*

Have you ever prayed to know the Lord’s will concerning choices you were making in your life? The Prophet Joseph Smith received the revelation in Doctrine and Covenants 88 after high priests at a conference had prayed separately and vocally to know the Lord’s will. Read Doctrine and Covenants 88:1–2, looking for what the Lord said about how He and the angels feel when His servants seek to know His will.

In Doctrine and Covenants 88:3–5, the Lord taught these brethren that they could receive an assurance of eternal life through the Holy Ghost, which is also called the Comforter and the Holy Spirit of Promise.

The Lord also taught about the significance of light. Have you ever been in complete physical darkness? How might an experience of being in complete darkness help you appreciate the blessing of light? What does light represent in the gospel of Jesus Christ?

Read Doctrine and Covenants 88:6–13, looking for what the Lord taught about the source of all light.

In verse 7, what term is used to refer to the truth that “shineth”? \_\_\_\_\_

According to verse 12, where does all light come from?

---

---

These verses teach that **through the Light of Christ, God gives light and life to all things**. You might want to write this doctrine in the margin of your scriptures. The Light of Christ is also the law that governs the universe and its inhabitants, and it “quickeneth” our understanding. *Quicken* means to make alive. You might want to write this definition in your scriptures.

### Define Difficult Words

It is important to define difficult words as you study the scriptures. This will help you better understand them. Check the scripture footnotes; use the Bible Dictionary, the Guide to the Scriptures, or other dictionaries; or ask a parent or teacher when you encounter words that you do not understand. It may be helpful to write the meaning of these words in your scriptures.

be baptized, and receive the gift of the Holy Ghost (see John 12:46; Alma 26:14–15).

“Conscience is a manifestation of the Light of Christ, enabling us to judge good from evil. The prophet Mormon taught: ‘The Spirit of Christ is given to every man, that he may know good from evil; wherefore, I show unto you the way to judge; for every thing which inviteth to do good, and to persuade to believe in Christ, is sent forth by the power and gift of Christ; wherefore ye may know with a perfect knowledge it is of God. . . . And now, my brethren, seeing that ye know the light by which ye may judge, which light is the light of Christ, see that ye do not judge wrongfully; for with that same judgment which ye judge ye shall also be judged’ (Moroni 7:16, 18)” (*True to the Faith: A Gospel Reference* [2004], 96).

President Boyd K. Packer of the Quorum of the Twelve Apostles further commented on the distinction and interaction between the Light of Christ and the Holy Ghost:



“Everyone everywhere already has the Spirit of Christ, and while the Spirit of the Holy Ghost can visit anyone, the *gift* of the Holy Ghost is obtained ‘by obedience to the laws and ordinances of the Gospel’ (Articles of Faith 1:3), by submitting to ‘baptism by immersion for the remission of sins; [and the] laying on of hands for the gift of the Holy Ghost’ (Articles of Faith 1:4). It is not automatically present like the Spirit of Christ is present. This gift must be conferred by one holding authority (see Articles of Faith 1:5).

“That is what we are commissioned to do, to foster the Light of Christ, which is within every soul we meet, and bring souls to the point where the Holy Ghost may visit them. And then, in due time, they can receive, through the ordinance, the gift of the Holy Ghost, which is conferred upon every member of the Church.

“Once a person has received that gift of the Holy Ghost and can cultivate it together with the Light of Christ, which they already have, then the fulness of the gospel is open to their understanding. The Holy Ghost can even work through the Light of Christ.

“The Light of Christ is as universal as sunlight itself. Wherever there is human life, there is the Spirit of Christ. Every living soul is possessed of it. It is the sponsor of everything that is good. It is the inspirer of everything that will bless and benefit mankind. It nourishes goodness itself” (“The Light of Christ,” *Ensign*, Apr. 2005, 13).



**1.** To help you think about how the Light of Christ blesses you daily, answer two or more of the following questions in your scripture study journal:

- In Doctrine and Covenants 88:7–10, we learn that all physical light, such as sunlight, is part of the Light of Christ. How does physical light bless your life?
- Quickeneth* or *quickeneth* means to bring to life or make alive. In Doctrine and Covenants 88:11, we learn that the Light of Christ is a means by which our understanding of things can be quickened, or made alive. When have you felt your learning or understanding quickened?
- In Doctrine and Covenants 88:12–13, we learn that the Light of Christ gives life to all things, which includes animals, plants, and even us. How have you been blessed by the living things around you?
- In Doctrine and Covenants 88:13, we also learn that the Light of Christ is the law by which all things are governed. This includes physical laws, like gravity, and spiritual laws and commandments. Through the Light of Christ, sometimes called our conscience, each of us can discern the difference between right and wrong. How do physical and spiritual laws affect you each day?

 **2.** Answer the following question in your scripture study journal: How do the truths you have learned help you appreciate God's influence in your daily life—in ways both noticed and generally unnoticed? Include some thoughts about how this will impact your daily life in coming days.

## Doctrine and Covenants 88:14–40

*The Lord explains that there are laws associated with the kingdoms of glory*

When you put on a glove, your hand animates, or gives life, to the glove. If you were teaching someone about the plan of salvation and you used a glove to represent the physical body we receive at birth, what could your hand represent?



Read Doctrine and Covenants 88:15, looking for what the Lord called the combination of the spirit and the body.

You might want to mark the doctrine that **the spirit and the body are the soul of man.**

 **3.** Answer the following questions in your scripture study journal: How can the things that affect our physical bodies also affect our spirits? What are some examples?

The following statement from President Ezra Taft Benson helps to explain the connection between our physical bodies and our spirits:

“There is no question that the health of the body affects the spirit, or the Lord would never have revealed the Word of Wisdom. God has never given any temporal commandments—that which affects our bodies also affects our souls. . . .

“ . . . Sin debilitates. It affects not only the soul, but the body. The scriptures are replete with examples of the physical power that can attend the righteous. On the other hand, unrepented sin can diffuse energy and lead to both mental and physical sickness” (“In His Steps,” *Ensign*, Sept. 1988, 5).

Note that in some verses of scripture the word *soul* is used specifically in reference to our spirit body (for example, see Alma 40:15–23).

 **4.** Answer the following question in your scripture study journal: How can understanding the connection between your body and your spirit help you make righteous decisions?



Consider some additional doctrines and principles that can be demonstrated by using a hand and a glove: Imagine removing your hand from a glove. What could this action represent? What happens to the soul—the spirit and the body—at death?

What could picking up the glove and putting it back on represent? What happens to the soul at resurrection?

Read Doctrine and Covenants 88:14, 16–17, looking for how the Lord described the Resurrection.

Complete the following doctrine taught in these verses: **Jesus Christ made it possible for our souls to** \_\_\_\_\_

In verse 17, after we read that Jesus Christ has redeemed our souls, we learn that those who are humble and meek will inherit the earth. Read Doctrine and Covenants 88:18–20, looking for what will happen to the earth before it becomes celestial and the redeemed souls inherit it.

According to verse 19, whose presence will be found on the sanctified earth? Ponder what you would say to someone who asked you the following question: What do I need to do to qualify to live in the celestial kingdom and enjoy the presence of Heavenly Father?

Just as the earth will receive glory after it is sanctified, our bodies will also be changed and receive glory in the Resurrection. However, not all people will receive the same degree of glory.

Read Doctrine and Covenants 88:21–24, and identify what determines the degree of glory a person receives in the Resurrection.





As you study Doctrine and Covenants 88:25–33, look for words and phrases that support the doctrine taught in verses 21–24, that **in the Resurrection, we will receive glory according to the law we obey.**

Verse 28 refers to those “who are of a celestial spirit.” Those are individuals who live according to the law of the celestial kingdom. We know from Doctrine and Covenants 76 that the law of the celestial kingdom includes making and keeping gospel covenants (see D&C 76:50–53, 69–70). A person who lives a celestial law on earth will receive a celestial body in the Resurrection. If a person only obeys a terrestrial or telestial law on earth, he or she will receive a body of lesser glory, according to the law he or she obeyed.

To help you understand why the laws of God are blessings to us, think about the benefits that come from obeying traffic laws. On the other hand, what are some consequences for disobeying traffic laws?

Read Doctrine and Covenants 88:34–35, looking for the consequences of living and refusing to live the laws of God.

 **5. Study Doctrine and Covenants 88:40, and identify qualities of people who will be drawn to the celestial kingdom. Then answer the following question and complete the following assignment in your scripture study journal:**

- a. What can you do to develop or strengthen these qualities in your life?
- b. Choose one of the qualities you identified, and write a personal goal to develop or strengthen that quality in your life.

As you fulfill your goal and live the laws of Jesus Christ, His light will fill your life.

 **6. Write the following at the bottom of today's assignments in your scripture study journal:**

*I have studied Doctrine and Covenants 88:1–40 and completed this lesson on (date).*

*Additional questions, thoughts, and insights I would like to share with my teacher:*

## UNIT 19: DAY 2

# Doctrine and Covenants 88:41–69

### Introduction

This is the second of three lessons that explore the revelation recorded in Doctrine and Covenants 88. The portion of the revelation covered in this lesson was given at a conference of high priests in Kirtland, Ohio, on December 27 and 28, 1832. It includes Jesus Christ's explanation of how God governs His creations and an invitation for us to draw near to Him.



### Doctrine and Covenants 88:41–50

*The Savior reveals that all things are governed by divine law*

Have you ever looked at the stars and thought about God and His creations? What questions or thoughts have you pondered as you gazed at the sky?

When people contemplate the vastness of God’s creations, they sometimes feel small and insignificant. They may wonder if God is aware of them. Many of the verses you will study today in Doctrine and Covenants 88 show God’s awareness of you and His desire to draw near to you.

Read Doctrine and Covenants 88:41. Think about how this verse shows that God has the power to be aware of you and your needs. Then read Doctrine and Covenants 88:42–45, and identify how God governs His creations, including the sun, moon, stars, and planets. You may want to mark what you find.

-  **1.** Think about some of God’s creations in the heavens and on the earth. In your scripture study journal, write about one of God’s creations that amazes you. What does that creation teach you about the Creator?
-  **2.** Read Doctrine and Covenants 88:46–47, looking for what the Lord said we are seeing when we view God’s creations. Then answer the following questions in your scripture study journal:
  - a.** What are we seeing when we view even the least of God’s creations?
  - b.** How do the creations you see in the heavens and on the earth help to increase your testimony of God?
-  **3.** Study Doctrine and Covenants 88:48–50. In your scripture study journal, summarize these verses in your own words. What do these verses teach about Jesus Christ?

## Doctrine and Covenants 88:51–61

*The Lord gives a parable of men laboring in a field and being visited in turn*

Doctrine and Covenants 88:51–60 contains a parable that helps us understand God’s interactions with the kingdoms He has created. A parable is a story that uses symbols to teach truth.

Read Doctrine and Covenants 88:51–55, looking for what the man in the parable commanded each of his servants to do and what he promised each of his servants.

In Doctrine and Covenants 88:56–60, we read that the lord of the field visited each of his servants when it was their turn: “They all received the light of the countenance of their lord, every man in his hour” (D&C 88:58).

Read Doctrine and Covenants 88:61, looking for what this parable teaches us about how God interacts with the kingdoms He has created.

The earth we inhabit is one of the kingdoms the Lord has promised to visit. One truth we can learn from this parable is that **the Lord will visit each of His kingdoms and their inhabitants in His time.** You may want to write this truth in your scriptures.



We will enjoy the Lord’s presence on the earth during the Millennium, after His Second Coming.

## Doctrine and Covenants 88:62–69

*God promises to draw near to us as we draw near to Him*

Ponder the following questions: How close do you feel to the Lord? Would you like to feel closer to Him?

Read Doctrine and Covenants 88:62–63, looking for things we can do to invite the Lord to draw near to us. You may want to mark what you find.

-  **4.** Do the following in your scripture study journal:
  - a.** Write a principle you learn from Doctrine and Covenants 88:63 about drawing near to the Lord.
  - b.** Write three action words from verse 63 that give you insight about how you can draw nearer to the Lord.
  - c.** Answer the following question: What have you done to seek, ask, and knock in order to draw nearer to the Lord?

Read Doctrine and Covenants 88:64, looking for what the Lord promises those who pray to the Father in His name.

What did the Savior teach about how Heavenly Father answers our prayers? In this verse the phrase “expedient for you” could be rephrased as “best for you.” Therefore, one principle we can learn from this verse is that **Heavenly Father answers our prayers in the ways that He knows are best for us.**



The following statement by Elder Richard G. Scott of the Quorum of the Twelve Apostles can help you understand why you should feel grateful even when Heavenly Father answers a prayer in a way that is different from what you hope or expect: “It is so hard when sincere prayer about something you desire very much is not answered the way you want. It is difficult to understand why your exercise of deep and sincere faith from an obedient life does not grant the desired result. . . . At times it is difficult to recognize what is *best* or *expedient* for you over time. Your life will be easier when you accept that what God does in your life is for your *eternal* good” (“Using the Supernal Gift of Prayer,” *Ensign* or *Liahona*, May 2007, 9).



**5. What should you do when the answers to prayers come in ways that you do not expect? In your scripture study journal, write about an experience you have had when Heavenly Father has answered your prayers in a way that was best for you.**

In Doctrine and Covenants 88:66, we learn that one way God communicates with us is “as the voice of one crying in the wilderness.” Read that verse, looking for how God’s voice reaches us. Think about times when you have felt that God has been near to you even though you have not seen Him.

Read Doctrine and Covenants 88:67–69, looking for additional ways you can draw near to the Lord. You may want to mark what you find.

Using these verses, complete the following statement:  
**If my eye is single to God’s glory, then \_\_\_\_\_**

In verse 67, the phrase “eye . . . single to my glory” means fully devoted to the work and purposes of God.



**6. Answer the following questions in your scripture study journal:**

- a. Who do you know who seems to be filled with the Lord’s light?
- b. In what ways do you see the Lord’s light in that person?

In verse 68, notice that in order to have your mind single to God, you need to sanctify yourself. The phrase “sanctify yourselves” refers to the need to be purified and cleansed from sin. You can become sanctified through the Atonement of Jesus Christ and the influence of the Holy Ghost as you repent of your sins, receive priesthood ordinances, and keep your covenants.



**7. Review the doctrines and principles you have identified in this lesson. Then imagine you are gazing at the stars with a friend who feels that God is not aware of him or her. In your scripture study journal, write what you would say to your friend.**

Conclude this lesson by reading and pondering the following statement by President Dieter F. Uchtdorf of the First Presidency:



“My dear brothers and sisters, it may be true that man is nothing in comparison to the greatness of the universe. At times we may even feel insignificant, invisible, alone, or forgotten. But always remember—you matter to Him! . . .

“God sees you not only as a mortal being on a small planet who lives for a brief season—He sees you as His child. He sees you as the being you are capable and designed to become. He wants you to know that you matter to Him” (“You Matter to Him,” *Ensign* or *Liahona*, Nov. 2011, 22).



**8. Write the following at the bottom of today’s assignments in your scripture study journal:**

*I have studied Doctrine and Covenants 88:41–69 and completed this lesson on (date).*

*Additional questions, thoughts, and insights I would like to share with my teacher:*



## UNIT 19: DAY 3

# Doctrine and Covenants 88:70–141

### Introduction

The portion of the revelation in Doctrine and Covenants 88 that this lesson focuses on includes the Lord’s instruction for a group of priesthood leaders to learn together by study and by faith and to show love and friendship toward each other. The Lord also foretells the signs of His Second Coming, the order of the Resurrection, and events surrounding the great and last battle with Satan.

### Doctrine and Covenants 88:70–117

*The Lord commands the elders of the Church to prepare for their ministry and reveals events surrounding His Second Coming*



The School of the Prophets met in the upper room of the Newel K. Whitney store until the Kirtland Temple was built.

In Kirtland, Ohio, in the winter of 1832–33, the Lord commanded a group of priesthood leaders to meet together in what was called the School of the Prophets to prepare themselves to preach the gospel among the nations of the earth. The Lord commanded this group to remain in Kirtland and learn from each other. Read Doctrine and Covenants 88:77–80, looking for what the Lord commanded these priesthood holders to do as they met together. You may want to mark what you find.

In Doctrine and Covenants 88:81–115, the Lord revealed many of the events that will precede and follow His Second Coming. He also revealed events that will occur at the end of the Millennium.

The Lord revealed that the dead will be resurrected in the order of their righteousness. Those who are resurrected first are those who inherit the celestial kingdom (see D&C 88:97–98, 107). Those who are resurrected second are those who inherit the terrestrial kingdom (see D&C 88:99). Those who inherit the telestial kingdom will be resurrected after the Millennium (see D&C 88:100–101). Finally, those who “remain filthy still”—those born on this earth who became sons of perdition—will be resurrected and cast into outer darkness (see D&C 88:102, 114).

### Doctrine and Covenants 88:118–26

*The Lord describes a pattern of learning*



1. In your scripture study journal, list some of the things you have recently learned about in school and in church.

Then answer the following question: How is learning about school subjects, such as math and science, different from learning about gospel subjects? How is it the same? (See D&C 88:78–79.)

Read Doctrine and Covenants 88:118, looking for how those who attended the School of the Prophets were to seek learning. You may want to mark what you find. What do you think it means to learn “by faith”?

As you read the following statement from Elder David A. Bednar of the Quorum of the Twelve Apostles, mark the words or phrases that help you better understand what it means to learn by faith:



“As learners, you and I are to act and be doers of the word and not simply hearers who are only acted upon. Are you and I agents who act and seek learning by faith, or are we waiting to be taught and acted upon? . . .

“ . . . Learning by faith requires spiritual, mental, and physical exertion and not just passive reception. It is in the sincerity and consistency of our faith-inspired action that we indicate to our Heavenly Father and His Son, Jesus Christ, our willingness to learn and receive instruction from the Holy Ghost. . . .

“ . . . Learning by faith requires both ‘the heart and a willing mind’ (D&C 64:34). Learning by faith is the result of the Holy Ghost carrying the power of the word of God both unto and into the heart. Learning by faith cannot be transferred from an instructor to a student . . . ; rather, a student must exercise faith



and act in order to obtain the knowledge for himself or herself" ("Seek Learning by Faith," *Ensign*, Sept. 2007, 64).

We can learn by faith when we actively and prayerfully engage in learning the gospel and then act on what we learn.

Notice at the beginning of Doctrine and Covenants 88:118 that the Lord indicated some did not have faith. From what you have learned from this verse, how would you complete the following principle about how to increase our faith? **If we \_\_\_\_\_, then our faith in Jesus Christ will increase.**

 **2.** To help you understand how this principle might be applied in your life, read each of the following situations. Then, in your scripture study journal, write how the person in each situation could change in order to learn by study and by faith. Also write how the person's actions would help the person increase in faith.

- a. A young woman regularly reads the scriptures, but she rarely pauses to think about what she is reading. She doesn't feel that reading the scriptures benefits her very much.
- b. A young man attends his Church meetings and enjoys participating in class discussions. Sometimes he feels prompted to make changes in his life based on what he learns, but he usually does not act on those promptings.

 **3.** Answer the following questions in your scripture study journal:

- a. When have you felt your faith increase as a result of actively seeking to learn by study and by faith?
- b. How did your actions help your faith to increase?
- c. What do you feel you should do in the future to seek learning by study and faith?

To learn more about the School of the Prophets, read Doctrine and Covenants 88:119–20, looking for how the Lord described the place where the School of the Prophets was to meet. You may want to mark what you find.

In response to the Lord's commandment to build the house described in verse 119, the Saints eventually built the Kirtland Temple. While the temple was under construction, the School of the Prophets met in the upper room of the Newel K. Whitney store in Kirtland.

Search Doctrine and Covenants 88:121–26, and identify how the Lord expected the brethren in the School of the Prophets to conduct themselves. Consider how these behaviors can help you as you study the gospel on your own and with others. You may want to ponder how the behaviors you identify can be applied to your own life.

 **4.** Answer the following question in your scripture study journal: What do you think it means to "cease from all your light speeches, from all laughter, . . . and light-mindedness" (D&C 88:121)?

The instructions concerning laughter and light-mindedness in speech given to those participating in the School of the Prophets meant that those participating in the School of the Prophets needed to be reverent in sacred settings. These meetings would eventually occur in the temple.

Why might obeying this counsel be helpful in your efforts to learn things that are sacred?

This counsel, however, does not mean that all laughter is sinful. With regard to laughter, President Gordon B. Hinckley told the youth of the Church:



"You can have a good time. Of course you can! We want you to have fun. We want you to enjoy life. . . . We want you to be robust and cheerful, to sing and dance, to laugh and be happy.

"But in so doing, be humble and be prayerful, and the smiles of heaven will fall upon you" ("A Prophet's Counsel and Prayer for Youth," *Ensign*, Jan. 2001, 11).

Notice the repetition of the word *all* in Doctrine and Covenants 88:122. Think about how a class could be affected if *all* of the students participated in the lesson and tried to learn from each other.

Doctrine and Covenants 88:124 contains instruction from the Lord concerning sleep. Consider how sleeping longer than is needful can affect our ability to learn or feel the Spirit. (D&C 88:124 is a scripture mastery verse. You may want to mark it in a distinctive way to help you find it in the future.)

In what ways do you think getting a proper amount of sleep and rising early can help us learn better? One principle that can be identified from the

### Writing about Impressions You Receive

Elder Richard G. Scott of the Quorum of the Twelve Apostles encouraged us to write about impressions we receive: "Write down in a secure place the important things you learn from the Spirit. You will find that as you write down precious impressions, often more will come. Also, the knowledge you gain will be available throughout your life. Always, day or night, wherever you are, whatever you are doing, seek to recognize and respond to the direction of the Spirit" ("To Acquire Knowledge and the Strength to Use It Wisely," *Ensign*, June 2002, 32).

Lord's instructions in Doctrine and Covenants 88:118–26 is that **doing righteous actions and ceasing unrighteous ones will help us to learn and be edified**. Consider writing this principle in the margin of your scriptures.

 **5.** Review Doctrine and Covenants 88:121–26, and determine which items of counsel you need to adopt more fully in your life. In your scripture study journal, write why you think following the Lord's counsel and doing these things are important to help you learn the gospel and be edified.

### Scripture Mastery—Doctrine and Covenants 88:124

 **6.** To help you memorize Doctrine and Covenants 88:124, list the six behaviors the Lord said to cease or follow in your scripture study journal. Repeat the list of actions until you can recite them from memory. To help you remember and apply the counsel in this scripture mastery passage, consider reciting it in your mind each time you attend a seminary or Church class or a family home evening for the next month.

### Doctrine and Covenants 88:127–41

*The Lord sets forth the order of the School of the Prophets*



Ponder some places where you study the gospel with others. Consider if there are people in these settings whom you don't know very well or struggle to get along with. Think about one of these people as you study Doctrine and Covenants 88:127–41. Ponder the following question: How does your relationship with those you learn the gospel with affect your ability to learn and be edified by the Spirit?

The Lord expected the members of the School of the Prophets to establish good relationships with each other as they learned together. Read Doctrine and Covenants 88:128–34, looking for the teacher's role in establishing a spiritual learning environment in the School of the Prophets. You may want to mark what you find.

The teacher saluting the members of the class means that he greeted them as they entered. This was a specific greeting in the School of the Prophets. What do you notice about the salutation or greeting in verse 133?

Read Doctrine and Covenants 88:135–37, looking for the students' role in establishing a good learning environment.

What kind of relationship did the Lord want the members of the School of the Prophets to have with each other? According to verse 137, what did the Lord promise if members of the School of the Prophets would follow His instructions?

The following is one principle we can learn in these verses: **If we show friendship and love to each other, then we can invite the Spirit as we study the gospel together.**

 **7.** Review the salutation in Doctrine and Covenants 88:133. Then answer the following questions in your scripture study journal:

- How do you think we can show "a determination that is fixed, immovable, and unchangeable, to be [a] friend" to class or family members whom we may not know well or may struggle to love?
- When have you experienced learning the gospel in an environment where everyone was determined to be friends? What was it like, or what do you think it would be like?

Think about how you can develop a determination to love those you learn the gospel with. You may want to record any promptings you feel to show greater kindness and love toward classmates and family members.

 **8.** Write the following at the bottom of today's assignments in your scripture study journal:

*I have studied Doctrine and Covenants 88:70–141 and completed this lesson on (date).*

*Additional questions, thoughts, and insights I would like to share with my teacher:*

# Doctrine and Covenants 89

## Introduction

On February 27, 1833, in response to the Prophet Joseph Smith's inquiries concerning the priesthood brethren's use of tobacco in their meetings, the Lord gave the revelation in Doctrine and Covenants 89, known as the Word of Wisdom. In it, the Lord warned against the use of harmful substances and encouraged the consumption of wholesome foods. The Lord also promised that those who follow the Word of Wisdom will be blessed both physically and spiritually.

## Doctrine and Covenants 89:1–3

*Joseph Smith introduces the revelation known as the Word of Wisdom*

Have you ever explained to someone why you do not drink alcohol, tea, or coffee or use tobacco? If so, do you remember what you said and how the person responded? This lesson will help you better understand the Word of Wisdom and be prepared to explain it to others.



In the winter of 1833, about 20 of the priesthood brethren began meeting in the upper room of Newel K. Whitney's store in Kirtland, Ohio, to attend the School of the Prophets. "At the meeting of the school held on

February 27, 1833, the Prophet received an important revelation. In the early days of the Church, the use of alcohol, tobacco, coffee, and tea was common in society and among Church members. As the Prophet saw the brethren using tobacco at the school, he became concerned. Brigham Young recalled: "When they assembled together in this room after breakfast, the first [thing] they did was to light their pipes, and, while smoking, talk about the great things of the kingdom. . . . Often when the Prophet entered the room to give the school instructions he would find himself in a cloud of tobacco smoke. This, and the complaints of his wife at having to clean so filthy a floor [from chewing tobacco], made the Prophet think upon the matter, and he inquired of the Lord relating to the conduct of the elders in using tobacco, and the revelation known as the Word of Wisdom was the result of his inquiry" (*Teachings of Presidents of the Church: Joseph Smith* [2007], 263).

Read the section introduction for Doctrine and Covenants 89, looking for what the Prophet Joseph Smith did in response to the brethren using tobacco. Then read Doctrine and Covenants 89:1–3, looking for words or phrases that describe the Lord's purposes in giving this revelation.

You may have identified that one purpose of this revelation deals with our temporal salvation. Temporal salvation has to do with our physical well-being.

Notice in Doctrine and Covenants 89:2 that the Word of Wisdom was not initially given as a commandment. President Joseph F. Smith explained: "At that time, . . . if [the Word of Wisdom] had been given as a commandment it would have brought every man, addicted to the use of these noxious things, under condemnation; so the Lord was merciful and gave them a chance to overcome, before He brought them under the law" (in Conference Report, Oct. 1913, 14).

Because of this, we should be careful not to judge some of the early Church leaders and members who, even after the Word of Wisdom was revealed, used substances that are prohibited today. Throughout the early history of the Church, leaders invited the Saints to more fully live the Word of Wisdom. In the fall general conference of 1851, President Brigham Young proposed that all Saints formally covenant to abstain from tea, coffee, tobacco, and whiskey. On October 13, 1882, the Lord revealed to President John Taylor that the Word of Wisdom was to be considered a commandment. In 1919, the First

Presidency, under President Heber J. Grant, made the observance of the Word of Wisdom a requirement for receiving a temple recommend. The Word of Wisdom continues to be an important commandment today, and obeying it is a prerequisite for baptism, temple attendance, missionary service, and other worthy service in the Church.

 **1.** In your scripture study journal, write the phrase *A Principle with Promise* (from D&C 89:3) as shown below. Leave some space to write the principles and promises of this revelation under those two parts of the phrase. You might also want to mark this phrase in your scriptures.

<i>A Principle</i>	<i>with Promise</i>
--------------------	---------------------

## Doctrine and Covenants 89:4–9

*The Lord warns the Saints not to use alcohol, tobacco, tea, or coffee*



Have you been fishing before?

In what ways does someone fishing try to deceive a fish into biting a hook?

Why might some people try to persuade you to partake of substances the Lord has forbidden? What lures, or methods, do they use to try to persuade you and others to use those substances? Read Doctrine and Covenants 89:4, looking for who the Lord warned would attempt to deceive the Saints in the last days.

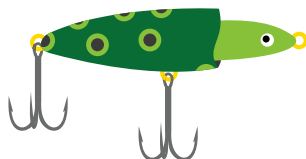

Write the following in your scripture study journal under the heading “A Principle”: ***Because of evil designs of conspiring men in the last days, the Lord warns us not to use harmful substances.***

The following statement from President Ezra Taft Benson helps us understand that one design of evil and conspiring men is to profit by selling addictive substances to others:



“The Lord foresaw the situation of today when motives for money would cause men to conspire to entice others to take noxious substances into their bodies. Advertisements which promote beer, wine, liquors, coffee, tobacco, and other harmful substances are examples of what the Lord foresaw. But the most pernicious example of an evil conspiracy in our time is those who induce young people into the use of drugs.

“My young brothers and sisters, in all love, we give you warning that Satan and his emissaries will strive to entice you to use harmful substances, because they well know if you partake, your spiritual powers will be inhibited and you will be in their evil power. Stay away from those places or people which would influence you to break the commandments of God. Keep the commandments of God and you will have the wisdom to know and discern that which is evil” (“A Principle with a Promise,” *Ensign*, May 1983, 54–55).

Read Doctrine and Covenants 89:5–9, looking for what substances the Lord warned the Saints not to take into their bodies. Consider marking what you find. (Church leaders have stated that the term “hot drinks” refers to tea and coffee.) In what ways are the substances in verses 5–9 harmful?

Notice that Doctrine and Covenants 89:7–8 says that alcohol and tobacco have proper as well as improper uses. Today there are other substances that can be misused so that they become harmful and addictive. Church leaders have warned against the use of “any drink, drug, chemical, or dangerous practice that is used to produce a ‘high’ or other artificial effect that may harm your body or mind. Some of these include marijuana, hard drugs, prescription or over-the-counter medications that are abused, and household chemicals” (*For the Strength of Youth* [booklet, 2011], 26).





2. Answer the following questions in your scripture study journal:

- In what ways is addiction like the hook that a person fishing uses to catch fish?
- Why is addiction damaging to our eternal progression?
- How has the warning to abstain from addictive and harmful substances blessed your life?

You will be blessed if you decide now to never partake of the substances that are contrary to the Word of Wisdom.

## Doctrine and Covenants 89:10–17

*God encourages the use of herbs, fruits, meat, and grains*



Read Doctrine and Covenants 89:10–17, looking for what the Lord encouraged us to eat. You might want to mark what you find. According to verse 11, what type of attitude should we have as we partake of these healthful foods?

It might be helpful to know that “with prudence” means wisely and carefully. An overabundance or imbalanced diet even of good food can be unhealthy.



3. Write a principle about healthful foods under the heading “A Principle” in your scripture study journal.

One example of the prudent use of food can be found in the instruction the Lord gave concerning meat in Doctrine and Covenants 89:12–13. The word *sparingly* suggests that meat is to be used in a moderate way.

## Doctrine and Covenants 89:18–21

*The Lord promises health, wisdom, and protection to those who obey the Word of Wisdom*

Write the following in your scripture study journal under the heading “Promise”: ***If we follow the Word of Wisdom, the Lord will bless us with . . .***

Read Doctrine and Covenants 89:18–19, and identify some of the blessings you can receive for obeying the Word of Wisdom.



4. Use what you learned from verses 18–19 to partially complete the sentence you wrote in your scripture study journal. (Leave room to add to this sentence later.) Then answer the following question: How can observing the Word of Wisdom help us obtain wisdom and knowledge?

President Boyd K. Packer of the Quorum of the Twelve Apostles explained one of the fundamental purposes of the Word of Wisdom:



“I have come to know . . . that a fundamental purpose of the Word of Wisdom has to do with revelation. . . .

“If someone ‘under the influence’ can hardly listen to plain talk, how can they respond to spiritual promptings that touch their most delicate feelings?”

“As valuable as the Word of Wisdom is as a law of health, it may be much more valuable to you spiritually than it is physically” (“Prayers and Answers,” *Ensign*, Nov. 1979, 20).

Think about how obeying the Word of Wisdom has allowed you to enjoy the companionship of the Holy Ghost, who reveals wisdom and knowledge to the faithful.

Read Doctrine and Covenants 89:20–21, looking for additional blessings that come from following the Word of Wisdom. (Doctrine and Covenants 89:18–21 is a scripture mastery passage. You may want to mark it in a distinctive way to help you find it later.)

 **5.** From what you learned from these verses, add to the sentence under the heading “Promise” in your scripture study journal. (Look at footnote 21a to help you understand the phrase “the destroying angel shall pass by.” This promise of divine protection can refer to physical as well as spiritual safety.) Then write an answer to the following question: When have the promises in Doctrine and Covenants 89:18–21 been fulfilled in your life or in the life of someone you know?

Consider setting a goal to better live the Word of Wisdom.

### Scripture Mastery—Doctrine and Covenants 89:18–21

 **6.** Copy the following headings and scripture references in your scripture study journal as shown:

Health	Wisdom	Strength	Protection
D&C 89:18	D&C 89:19	D&C 89:20	D&C 89:21

Choose one of the verses, and work to memorize it for a few minutes. See if you can recite it to a family member or a friend. To memorize the entire passage, you may want to choose other verses and designate a time to work on memorizing them in the future.

 **7.** Write the following at the bottom of today’s assignments in your scripture study journal:

*I have studied Doctrine and Covenants 89 and completed this lesson on (date).*

*Additional questions, thoughts, and insights I would like to share with my teacher:*

## UNIT 20: DAY 1

# Doctrine and Covenants 90–92

### Introduction

On March 8, 1833, the Lord gave the revelation recorded in Doctrine and Covenants 90, which contains instructions to the Presidency of the High Priesthood. “This revelation is a continuing step in the establishment of the First Presidency” (D&C 90 section introduction). The following day, the Prophet Joseph Smith inquired whether he should translate the Apocrypha as part of his inspired revisions to the Bible. The Lord responded to his inquiry through the

revelation recorded in Doctrine and Covenants 91 and told Joseph it was not needful for him to translate it. Just a few days later, on March 15, 1833, the Prophet received a revelation (D&C 92) that instructed Frederick G. Williams, one of the counselors to the Prophet, on his duties in the United Firm, which was established to oversee the welfare and business affairs of the Church.

### Doctrine and Covenants 90:1–18

*The Lord instructs the Presidency of the High Priesthood concerning their responsibilities*

What is the most valuable gift you have ever received? Why is it valuable?

Read Doctrine and Covenants 90:1–3, looking for the valuable things the Prophet Joseph Smith was given. According to these verses, what did the Prophet hold?

The phrase “keys of the kingdom” refers to the right of presidency, or the authority God gives man to preside over, govern, and direct His kingdom on the earth.

Read Doctrine and Covenants 90:4–5, and identify the warning the Lord gave the Saints. As used in these verses, the term *oracles* refers to revelations from God through His prophets.



You may want to write the following principle in the margin of your scriptures next to verse 5: ***If we treat lightly the revelations God gives through His prophets, we will stumble and fall.***



1. Answer the following questions in your scripture study journal:

- What do you think it means to treat the revelations God gives through His prophets “as a light thing” (D&C 90:5)?
- What are some examples of revelations people might be tempted to treat lightly?

Read Doctrine and Covenants 90:6, looking for who else the Lord said would hold the keys of the kingdom. You may want to mark words or phrases in this verse that teach the truth that **the First Presidency holds the keys of the kingdom.** (Members of the Quorum of the Twelve Apostles would also be given the keys of the kingdom when that quorum was organized in 1835. Their use of these keys would be under the direction of the President of the Church.)

On March 18, 1833, 10 days after the revelation in Doctrine and Covenants 90 was given, Joseph Smith set apart Sidney Rigdon and Frederick G. Williams as counselors in the Presidency of the High Priesthood, which later became known as the First Presidency of the Church.

Doctrine and Covenants 90:7–10 contains instruction to the First Presidency to prepare members of the School of the Prophets to preach the gospel throughout the world. Read Doctrine and Covenants 90:11, and consider how this verse is being fulfilled today.

Doctrine and Covenants 90:12–18 describes some of the responsibilities of the First Presidency, which include setting in order all the affairs of the Church. Because the First Presidency holds the keys of the kingdom, you will be blessed as you follow their teachings.

## Doctrine and Covenants 90:19–37

### *The Lord instructs the Saints in Zion*

What do you do when circumstances in your life become very difficult?

When the Prophet Joseph Smith received the revelation in Doctrine and Covenants 90, he and other Church leaders were in a difficult situation because of the Church’s lack of financial resources. Doctrine and Covenants 90:19–37 contains the Lord’s instruction to early Church leaders on how to handle the difficult circumstances they faced.

Read Doctrine and Covenants 90:24, and identify counsel that could comfort anyone who might be going through a difficult situation.

Complete the following principle based on the Lord’s promise in verse 24: **If we will \_\_\_\_\_ diligently, \_\_\_\_\_ always, be \_\_\_\_\_ and keep our \_\_\_\_\_ all things will work together for our good.**

Searching diligently includes more than reading the scriptures. President Harold B. Lee said: “Diligence means to be industrious, the opposite of being lazy or careless or indifferent. In other words, they must search to know the doctrines of the Church” (*Stand Ye in Holy Places: Selected Sermons and Writings of President Harold B. Lee* [1974], 198).

What do you think it means that “all things will work together for your good” (D&C 90:24)?

This does not mean that nothing bad will happen to us. Rather, it means that God will strengthen us during difficult times if we are faithful and that our challenges can bring us needed experiences and blessings.



2. In your scripture study journal, write about an experience you have had or witnessed in the life of someone else that illustrates the truthfulness of this principle.

One Church member who demonstrated great faithfulness during difficult times was Vienna Jaques. Study Doctrine and Covenants 90:28–31, and identify the specific instructions the Lord gave her. Study the following information about Sister Jaques, looking for ways she was faithful to the Lord’s instructions. As you study this, you may want to underline some of the difficult circumstances Vienna experienced (try to find at least three).



Vienna Jaques

Vienna Jaques is an example of the faithfulness of many early Latter-day Saints. She was born June 10, 1787. After she met the missionaries in Boston, Massachusetts, USA, she traveled to Kirtland, Ohio, in 1831. She stayed there six weeks and was baptized. Upon returning to Boston, Vienna helped bring several members of



her family into the Church. She then “settled up her business and went back to Kirtland to unite her interests forever with the Church” (“Home Affairs,” *Woman’s Exponent*, July 1, 1878, 21). In 1833, Vienna consecrated all of her possessions, including \$1,400, to the Church during a time when the money was desperately needed. She then traveled to Missouri to receive her inheritance in Zion. However, soon after she arrived she suffered persecution with the Saints. After being driven from her home in Missouri, she attended to the sick in Zion’s Camp. Heber C. Kimball wrote, “I received great kindness . . . from Sister Vienna Jaques, who administered to my wants and also to my brethren—may the Lord reward [her] for [her] kindness” (“Extracts from H. C. Kimball’s Journal,” *Times and Seasons*, Mar. 15, 1845, 839–40).

While in Missouri, Vienna Jaques married Daniel Shearer. In 1847, at the age of 60, she traveled west to Utah, driving her own wagon across the plains. She settled in Salt Lake City and for the rest of her life worked hard to support herself and diligently study the scriptures. Sister Jaques died on February 7, 1884, at the age of 96. Her obituary stated: “She was true to her covenants and esteemed the restoration of the Gospel as a priceless treasure” (“In Memoriam,” *Woman’s Exponent*, Mar. 1, 1884, 152; see also Susan Easton Black, “Happiness in Womanhood,” *Ensign*, Mar. 2002, 12, 14).

 **3.** In your scripture study journal, write what you learned about hardship and faithfulness from Vienna Jaques’s example.

## Doctrine and Covenants 91

### *The Savior instructs Joseph Smith not to translate the Apocrypha*

How can you know if something you read on the Internet or in a newspaper or magazine is true? The revelation recorded in Doctrine and Covenants 91 instructed the Prophet Joseph Smith how to discern if something he was reading was true. Read the section introduction, looking for what Joseph Smith was doing at the time he received this revelation.

The Apocrypha is a collection of sacred books of the Jewish people. They were not originally included in the Hebrew Bible, but they were included in the Greek translation of the Bible at the time of Christ. Some of the books bridge the time period between

the Old Testament and the New Testament. When early Christians compiled the books of the Bible centuries later, they included the books of the Apocrypha, but there were questions about whether they belonged as part of the scriptures. The copy of the Bible Joseph Smith was using while working on his inspired translation contained the Apocrypha. However, because the validity of the Apocrypha was in question, Joseph asked the Lord if his translation of the Bible should include these books.

Read Doctrine and Covenants 91:1–3, looking for what the Prophet Joseph Smith learned about the Apocrypha. *Interpolations* are additions to a manuscript that sometimes alter the meaning and corrupt the original text.

Read Doctrine and Covenants 91:4–6, and identify how those who study it can know what was true in the Apocrypha.

From these verses we can learn the following truth:  
**The Holy Ghost can help us know if the things we read are true.**

President Dieter F. Uchtdorf of the First Presidency taught:



“Never in the history of the world have we had easier access to more information—some of it true, some of it false, and much of it partially true.

“Consequently, never in the history of the world has it been more important to learn how to correctly discern between truth and error. . . .

“The Holy Ghost is a revelator. He is the Comforter, who teaches us ‘the truth of all things.’ . . .

“The *Witness* of truth from the Holy Ghost is available to all, everywhere, all around the globe. All who seek to know the truth, who study it out in their minds, and who ‘ask with a sincere heart, with real intent, having faith in Christ, [will know] the truth . . . by the power of the Holy Ghost.’ [Moroni 10:4.]” (“What Is Truth?” [Church Educational System devotional address, Jan. 13, 2013], 3, 6; speeches.byu.edu).

 **4.** In your scripture study journal, write about an experience when you felt the Holy Ghost confirm that something you read was true.



## Doctrine and Covenants 92

*Frederick G. Williams is to be received into the United Firm*

The revelation contained in Doctrine and Covenants 92 instructed Church leaders who were part of the United Firm (which was also called the United Order) to accept Frederick G. Williams into the firm. Read Doctrine and Covenants 92:1–2, and identify how the Lord wanted Brother Williams to act as a member of the firm.

 **5.** “A lively member” of a group is one who is active and committed. Select two or more of the following situations, and in your scripture study journal, write what “a lively member” of the Church might do in those situations.

- a. A young man has been assigned to be a home teacher.
- b. A youth has been called as president of a Young Women class or priesthood quorum.
- c. A youth is a student in a Sunday School class.
- d. A youth is a neighbor of an elderly couple.

Ponder what you can do to be a lively member of the Church today.

In Doctrine and Covenants 92:2, the Lord also taught Frederick G. Williams what he must do to “be blessed forever.” You may want to mark this instruction in your scriptures.

 **6.** Write the following at the bottom of today’s assignments in your scripture study journal:

*I have studied Doctrine and Covenants 90–92 and completed this lesson on (date).*

*Additional questions, thoughts, and insights I would like to share with my teacher:*

come unto the Father in my name, and in due time receive of his fulness” (D&C 93:19). These verses will be covered in more detail when you meet with your teacher for the weekly lesson. This lesson primarily focuses on what the Lord revealed in Doctrine and Covenants 93:21–53. These verses include the Lord’s instruction on gaining truth and light and the need to be “diligent and concerned at home” (D&C 93:50).

## Doctrine and Covenants 93:1–20

*The Lord reveals how we can become like Him and our Heavenly Father*

In Doctrine and Covenants 93:1–20, we learn about Jesus Christ, His relationship with Heavenly Father, and how we can receive “a fulness of the glory of the Father” (D&C 93:16) as He did.



John the Baptist bore strong testimony of Jesus Christ.

The Apostle John was a disciple of John the Baptist when Jesus Christ began His mortal ministry. He gave an account of the testimony John the Baptist bore of the Savior in the Gospel of John in the New Testament. Regarding this inclusion of the testimony of John the Baptist, Elder Bruce R. McConkie of the Quorum of the Twelve Apostles explained:

“From the latter-day revelation we learn that the material in the forepart of the gospel of John (the Apostle, Revelator, and Beloved Disciple) was written originally by John the Baptist. By revelation the Lord restored to Joseph Smith part of what John the Baptist

## UNIT 20: DAY 2

# Doctrine and Covenants 93

### Introduction

On May 6, 1833, the Prophet Joseph Smith received the revelation recorded in Doctrine and Covenants 93. Jesus Christ explained the purpose of the first part of this revelation (D&C 93:1–20): “I give unto you these sayings that you may understand and know how to worship, and know what you worship, that you may

had written and promised to reveal the balance when men became sufficiently faithful to warrant receiving it. (D. & C. 93:6–18.) [Doctrine and Covenants 93:15] is the key to the identity of the particular John spoken of. . . .

“. . . There is little doubt but that the Beloved Disciple had before him the Baptist’s account when he wrote his gospel. The latter John either copied or paraphrased what the earlier prophet of the same name had written. The only other possibility is that the Lord revealed to the gospel author the words that had been recorded by the earlier messenger who prepared the way before him” (*Doctrinal New Testament Commentary*, 3 vols. [1966–73], 1:70–71).

In Doctrine and Covenants 93:6–17, the Lord gave information from John’s record to help us understand more about Him. John taught that **Jesus Christ grew from grace to grace until He received a fulness of the glory of the Father.**

We too can receive a fulness of the glory of the Father as we follow the example of Jesus Christ. You may want to mark phrases that teach this truth in Doctrine and Covenants 93:19–20.

### Doctrine and Covenants 93:21–39

*The Lord instructs His servants on how to receive truth and light*

What are some responsibilities of being the firstborn child in a family?

Read Doctrine and Covenants 93:21–23, looking for what Jesus Christ revealed about Himself.

You may want to mark words or phrases in those verses that teach the following doctrine: **Jesus Christ is the Firstborn among all the spirit children of Heavenly Father.**

Because Jesus Christ is the Firstborn spirit child of the Father, He is the “appointed heir” (Hebrews 1:2) of all the Father has. However, He wants all of Heavenly Father’s children to share in this inheritance. We have the opportunity to be “joint-heirs with Christ” (Romans 8:17) and be numbered among “the church of the Firstborn” (D&C 93:22; see also D&C 76:51–54). Elder Bruce R. McConkie taught that “members of The Church of Jesus Christ of Latter-day Saints who so devote themselves to righteousness that they receive the higher ordinances of exaltation become members of the *Church of the Firstborn*” (*Mormon Doctrine*, 2nd ed. [1966], 139). In this way we also can receive all that the Father has (see D&C 76:55; 84:37–38).



According to Doctrine and Covenants 93:22, we must be begotten through Jesus Christ in order to be partakers of the glory of the Firstborn. To be begotten through Jesus Christ means to be spiritually reborn and cleansed from all sin through the power of the Atonement.

 **1.** In your scripture study journal, explain why it is important for you to understand Jesus Christ’s role as the Firstborn of the Father. You may also want to record the feelings you have for Jesus Christ as you consider what His role as the Firstborn of the Father means for you.

Notice in Doctrine and Covenants 93:21 that Jesus Christ said He was “in the beginning with the Father.” According to verse 23, who else was in the beginning with the Father?

Doctrine and Covenants 93:23 can be applied to all of Heavenly Father’s spirit children. You might replace the word *ye* in this verse with your own name. You could write your name in the margin of your scriptures and draw a line to the word *ye*.

**Inserting Your Name into Verses You Study**

Using your own name or inserting the word *I* or *me* in suitable places in the scriptures can help scriptures become more meaningful and help you see how certain passages may relate to you.

While we lived with Heavenly Father and Jesus Christ in the premortal life, we were taught by Them and had the opportunity to accept or reject truth. Read Doctrine and Covenants 93:24–26, looking for what the Lord taught about truth in these verses.

In the space provided, write about what you learn from the Lord’s definition of truth in verse 24: \_\_\_\_\_

\_\_\_\_\_

Notice how Satan is described in Doctrine and Covenants 93:25. Notice how he seeks to influence us by distorting and diminishing our knowledge of the truth. In comparison, ponder what we learn about the Savior in verse 26.

Search Doctrine and Covenants 93:36–37, and identify additional principles the Lord revealed about light and truth. You may want to mark the phrase “the glory of God is intelligence, or, in other words, light and truth” in verse 36. Remember that Heavenly Father and Jesus Christ have a fulness of glory, which includes a fulness of intelligence, or light and truth. Ponder how we benefit by receiving light and truth in our lives. One benefit is that **by receiving light and truth, we can become like Jesus Christ and Heavenly Father.** (You may want to write this principle in the margin of your scriptures next to verse 36.)



 **2.** In your scripture study journal, write about why it is important for you to understand that by receiving light and truth we can become like Jesus Christ and Heavenly Father.

Read Doctrine and Covenants 93:27–28, looking for what we must do to receive truth and light. In the oval on the right side of the accompanying diagram, write a principle that teaches how we receive truth and light.

**By receiving light and truth, we can become like Jesus Christ and Heavenly Father.**

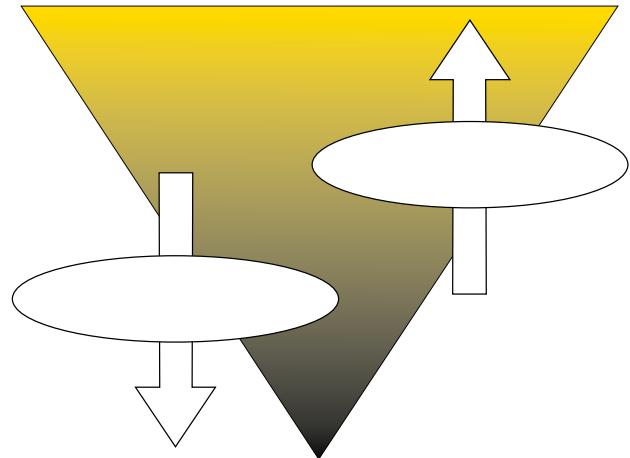

 **3.** Answer the following questions in your scripture study journal:

- a. How does obeying the commandments help us receive truth and light?
- b. When have you felt that you received truth and light by keeping the commandments?

When we lived with God before we were born on earth, we had agency—the ability to choose and act for ourselves. Read Doctrine and Covenants 93:29–32, looking for how our use of agency affects our ability to receive light and truth.

According to verses 31–32, what is the consequence if we choose not to receive truth and light?

These verses help us understand that we place ourselves under condemnation and hinder our spiritual progression by refusing to receive the light that is available to us.

Can we lose light and truth that we have already received? Search Doctrine and Covenants 93:39 to find an answer to this question.

In the oval on the left side of the diagram, write a principle stating what causes us to lose light and truth.



 4. In your scripture study journal, list some examples of traditions, or activities commonly done by many people, that could cause us to lose light and truth. Write a few sentences explaining how participating in one of these traditions could affect our ability to receive and keep light and truth from our Heavenly Father.

The following scenario can help illustrate how our personal choices to obey or disobey God's commandments affect our ability to receive light and truth or to lose it. Read the following narrative, and identify how Maria's choices affect her ability to receive light and truth. Pause after each paragraph, and think about why Maria's condition has changed.

Maria prays each morning and evening. She feels joy giving service, keeping her covenants, and searching the scriptures daily. She regularly helps gather her family together for family scripture study and prayer. She looks forward to partaking of the sacrament each week at church.

Maria's life has become busier. She still prays and studies the scriptures often but not every day. She attends church most of the time and usually listens to those who speak and teach. She goes to Young Women activities if she knows that her friends will be there.

Maria has become more involved in activities with friends who do not follow Church standards. She prays if she isn't tired or in a hurry. She helps around the house reluctantly and reads scriptures with the family only if it is convenient. She usually skips Church and Young Women activities. She occasionally breaks the Word of Wisdom.

Maria spends most of her time with friends instead of her family. She never prays, reads the scriptures, or attends Church meetings. The bishop has asked to see her, but she will not speak to him. She often breaks the Word of Wisdom. She argues constantly with family members. She feels distant from Heavenly Father.

 5. In your scripture study journal, write about the importance of the decisions you make each day and how they affect the light and truth you receive and keep.

## Doctrine and Covenants 93:40–53

*The Lord counsels His servants to set their homes in order*



Consider how interactions with your parents or other family members can help you to grow in light and truth.

Read Doctrine and Covenants 93:40, and identify the responsibility God has given to parents.

In Doctrine and Covenants 93:41–48, the Lord instructed Frederick G. Williams, Sidney Rigdon, and Joseph Smith Jr. to do better at teaching their children light and truth and in ways in which they could set their families in order.

Read Doctrine and Covenants 93:49–50, looking for the Lord's warning that applies to all families. As you study these verses, you may want to mark words or phrases that teach the following principle: **We must pray always and be diligent and concerned at home, or the wicked one will have power over us.**

Although this warning was given to a father, it applied to his whole family. Elder David A. Bednar of the Quorum of the Twelve Apostles explained ways that we can be "more diligent and concerned at home":

*"Suggestion Number One: Express Love—and Show It*

*"We can begin to become more diligent and concerned at home by telling the people we love that we love them. Such expressions do not need to be flowery or lengthy. We simply should sincerely and frequently express love. . . .*

*". . . Children, when was the last time you told your parents that you love them? . . .*



“We should remember that saying ‘I love you’ is only a beginning. We need to say it, we need to mean it, and most importantly we need consistently to show it. We need to both express and demonstrate love. . . .

*“Suggestion Number Two: Bear Testimony—and Live It*

“We also can become more diligent and concerned at home by bearing testimony to those whom we love about the things we know to be true by the witness of the Holy Ghost. The bearing of testimony need not be lengthy or eloquent. . . .

“. . . Children, when was the last time you shared your testimony with your parents and family? . . .

“We should remember that bearing a heartfelt testimony is only a beginning. We need to bear testimony, we need to mean it, and most importantly we need consistently to live it. We need to both declare and live our testimonies. . . .

*“Suggestion Number Three: Be Consistent*

“Each family prayer, each episode of family scripture study, and each family home evening is a brushstroke on the canvas of our souls. No one event may appear to be very impressive or memorable. But . . . our consistency in doing seemingly small things can lead to significant spiritual results. . . . Consistency is a key principle as we lay the foundation of a great work in our individual lives and as we become more diligent and concerned in our own homes” (“More Diligent and Concerned at Home,” *Ensign* or *Liahona*, Nov. 2009, 17–20).

 **6.** What do you think it means to be “diligent and concerned at home” (D&C 93:50)? In your scripture study journal, write about one thing you will do to be more diligent and concerned at home.

 **7.** Write the following at the bottom of today’s assignments in your scripture study journal:

*I have studied Doctrine and Covenants 93 and completed this lesson on (date).*

*Additional questions, thoughts, and insights I would like to share with my teacher:*

**UNIT 20: DAY 3**

# Doctrine and Covenants 94–96

## Introduction

The Lord gave the revelation recorded in Doctrine and Covenants 94 on August 2, 1833, and directed the Saints to lay out the city of Kirtland, Ohio, similar to the city of Zion in Missouri. The Lord also commanded the Saints to build a house (a Church administration building) for the First Presidency and a house for printing, in addition to the temple, which He had previously commanded the Saints to build. Two months earlier, on June 1, 1833, the Prophet Joseph Smith had received the revelation recorded in Doctrine and Covenants 95, in which the Lord chastened the Saints for delaying construction of the temple. Doctrine and Covenants 96 contains the Lord’s instruction to appoint Newel K. Whitney “to take charge of” (D&C 96:2) the property on which the temple in Kirtland would be built.

## Doctrine and Covenants 94

*The Lord commands the Saints to construct two houses and reaffirms the need to build the temple*



Imagine that you have the opportunity to travel through a country with many cities. As you travel, you notice that there is a sports arena at the center of every city. What might this suggest about the people of this country?

If you were going to design a large city, what would you place at the center of the city? Why?

Read Doctrine and Covenants 94:1–2, looking for how the Lord directed the city of the stake of Zion in Kirtland, Ohio, to be designed.

What does this say about the importance of the temple to the Lord?

Read Doctrine and Covenants 94:3, 10, and identify the two other buildings the Lord commanded the Saints to construct in Kirtland.

The commandment to construct these buildings shows the importance the Lord places on temple ordinances, the work of the First Presidency in obtaining revelation and ministering to the Church, and the publishing of scriptures and other works the Lord commands.

Read Doctrine and Covenants 94:6–8, 12, looking for phrases that communicate the sacredness of these buildings.

The Lord instructed Hyrum Smith, Reynolds Cahoon, and Jared Carter to form a building committee for the buildings mentioned in this revelation (see D&C 94:13–17).

Read Doctrine and Covenants 94:16, looking for what the Lord told the Saints concerning the construction of the buildings for the First Presidency and for printing.

Consider why it was important for the temple to be built before the other two buildings. What can this teach us about the importance of temples?

## Doctrine and Covenants 95

### *The Lord chastens the Saints for delaying construction of the temple*

The Lord first issued the commandment to build the Kirtland Temple in Doctrine and Covenants 88:119, which was recorded on December 27–28, 1832.

Search the section introduction to Doctrine and Covenants 95 for the date when this revelation was given. Approximately how much time passed between these two dates?

During this time, Church leaders had acquired property in Kirtland on which to build the temple. However, by June 1, 1833, the Saints had not begun constructing the temple or even preparing the foundation.

Read Doctrine and Covenants 95:1–3, and identify what the Lord told the Saints concerning their delay in building the temple.

Refer to verse 1 to complete the following statement:  
**God chastens** \_\_\_\_\_.



To chasten means to discipline or correct. In verse 1, you may want to mark reasons why God chastens those He loves.

Consider how you tend to respond when you are chastened or corrected. As you read the following narrative, look for ways some of the brethren responded to the Lord's chastening:

After the Prophet Joseph Smith received the revelation recorded in Doctrine and Covenants 95, Church leaders held a conference to discuss the construction of the temple. "Some were in favor of building a frame house, but others were of a mind to put up a log house. Joseph reminded them that they were not building a house for a man, but for God; 'and shall we, brethren,' said he, 'build a house for our God, of logs? No, I have a better plan than that. I have a plan of the house of the Lord, given by himself; and you will soon see by this, the difference between our calculations and his idea of things'" (Lucy Mack Smith, *History of Joseph Smith by His Mother*, ed. Preston Nibley [1958], 230). After the Prophet explained the full pattern of the temple, all of the brethren were excited. They traveled to the building site, removed a fence, and leveled a field of wheat that had previously been planted by the Smith family. After the grain was cleared, Hyrum

Smith “commenced digging a trench for the wall, he having declared that he would strike the first blow upon the house” (Lucy Mack Smith, *History of Joseph Smith*, 231).

 **1. In your scripture study journal, write what you can learn from these brethren about how to respond to correction or discipline. In addition, write about a time when you were chastened and responded by seeking to improve.**

Notice that the Lord described the Saints’ delay in building the temple as “a very grievous sin” (D&C 95:3). Why do you think the Lord would consider the delay in building the temple as a serious sin? Search Doctrine and Covenants 95:6 to see what the Lord compared this very grievous sin to.

Consider how ignoring the Lord’s commandments—particularly the commandment to build a temple—might be like walking in darkness at noonday.

Read Doctrine and Covenants 95:4, 8–9, and identify reasons why the Lord commanded the Saints to build the Kirtland Temple. (The phrase “that I may bring to pass my strange act” [D&C 95:4] refers to the Lord’s latter-day work and how people who do not believe in revelation, heavenly visitations, and other spiritual matters might consider the Restoration of the gospel to be strange.)

From these verses we learn that **in temples, the Lord prepares His servants to do His work and endows them with power.**

The word *endow* means to provide someone with a gift. To be endowed in the temple means to receive spiritual power and knowledge. In the Kirtland Temple, the Lord would restore the priesthood keys essential to perform the saving ordinances that today we can receive only in temples: the temple endowment and the temple sealing (see D&C 110).



President Thomas S. Monson spoke about the importance of receiving these temple blessings: “Until you have entered the house of the Lord and have received all the blessings which await you there, you have not obtained everything the Church

has to offer. The all-important and crowning blessings of membership in the Church are those blessings which we receive in the temples of God” (“The Holy Temple—a Beacon to the World,” *Ensign* or *Liahona*, May 2011, 93).

 **2. Write in your scripture study journal about some things you can do now to prepare to receive the ordinances and blessings of the temple.**

Building the Kirtland Temple was an enormous task for the Saints. In the early part of 1833, there were fewer than 200 members of the Church in Ohio, and most of them were poor. Read Doctrine and Covenants 95:11–12, looking for what the Lord promised if the Saints would keep His commandments.

The Saints in Ohio proceeded with faith in the Lord’s promise and constructed the temple. From Doctrine and Covenants 95:11, we learn that **if we keep the commandments, we will have power to do what the Lord asks us to do.** You may want to write this principle in the margin of your scriptures.

 **3. Answer the following questions in your scripture study journal:**

- What are some situations you might face in which this principle could apply?
- When have you felt that you have received the Lord’s help to do something because you have kept the commandments?

Notice the phrase “the love of the Father shall not continue with you” in Doctrine and Covenants 95:12. When we fail to obey the commandments of the gospel, we lose blessings, such as light and knowledge, which are fruits of the Father’s love for those who show their love for Him by being obedient.



In Doctrine and Covenants 95:13–17, we read that the Lord gave the brethren instructions on the dimensions and the functions of specific rooms of the Kirtland Temple. Read verse 14, looking for one way the Lord



indicated He would fulfill His promise to give His people power to build the temple.

The three men whom the Lord promised to show how to build the temple were the First Presidency. The following information will help you see how this promise was fulfilled:

Joseph Smith, Sidney Rigdon, and Frederick G. Williams prayed together and saw the temple in vision. After viewing the exterior in detail, “the building seemed to come right over [them]” and they saw the interior of the building as if they were actually inside of it (see *Teachings of Presidents of the Church: Joseph Smith* [2007], 271). Later, when the temple was nearing completion, Frederick G. Williams said that it looked like the model he had seen in vision to the smallest detail and that he could not tell the difference.

## Doctrine and Covenants 96

*Newel K. Whitney is designated to take charge of the temple property for the Church*

In Doctrine and Covenants 96, we read that the Lord instructed that Bishop Newel K. Whitney should take charge of the property on which the temple would be built. The Lord also commanded Bishop Whitney to divide the property into lots for those who seek an inheritance. Some of the lots were designated for Church leaders responsible for the publication of the revelations. Receiving this inheritance would help them devote their time to doing the work of the Lord. Read Doctrine and Covenants 96:4–5, and identify how publishing the word of God would help the Saints.

In this revelation the Lord also directed that John Johnson should be admitted as a member of the United Firm, which oversaw the Church’s financial, publishing, and business operations.

 **4.** Write the following at the bottom of today’s assignments in your scripture study journal:

*I have studied Doctrine and Covenants 94–96 and completed this lesson on (date).*

*Additional questions, thoughts, and insights I would like to share with my teacher:*

## UNIT 20: DAY 4

# Doctrine and Covenants 97

## Introduction

The Prophet Joseph Smith received the revelation recorded in Doctrine and Covenants 97 on August 2, 1833. In this revelation, the Lord provided instruction and encouragement for Parley P. Pratt, who presided over a school for priesthood brethren in Missouri, and for the brethren who attended that school. The Lord also emphasized His will that the Saints in Missouri build a temple. He promised that if they did so, and if their hearts were pure, His glory and presence would dwell there.



A school for the elders

## Doctrine and Covenants 97:1–9

*The Lord teaches members of the school of elders in Missouri what they must do to be accepted of Him*

If you were to teach a friend how to be a good student, what attributes and behaviors would you encourage your friend to develop?

In the winter of 1832–33, the Lord directed Church leaders to establish the School of the Prophets in Kirtland, Ohio. Under the direction of the Prophet Joseph Smith, Parley P. Pratt conducted a similar school in Independence, Missouri. This school was called a school for the elders. Members of the school for the elders wrote letters to Joseph Smith, who was in Ohio. In response, he sent them a letter containing



the revelation that is now recorded in Doctrine and Covenants 97. Read Doctrine and Covenants 97:1, and identify how the Lord described many of the brethren in Missouri.

Read Doctrine and Covenants 97:2, and identify what the Lord promised these men if they continued to be faithful.

From Doctrine and Covenants 97:1–2, we learn that **if we humble ourselves and seek diligently to learn, we will obtain wisdom and truth**. You may want to write this principle in your scriptures.



 **1. Answer the following questions in your scripture study journal:**

- a. Why is it important to you to obtain wisdom and truth?
- b. How do you think being humble and diligent will help you obtain wisdom and truth?

Read Doctrine and Covenants 97:3–5 to learn how the Lord felt about Parley P. Pratt’s service and what the Lord promised Brother Pratt.

Like Parley P. Pratt, you can know that the Lord is pleased with you as you continue to follow Him.

 **2. Read Doctrine and Covenants 97:7, 9. In your scripture study journal, draw the trees described in these verses. (If you prefer not to draw, you could write two paragraphs describing the trees.)**

The two types of trees represent Church members, and the fruits represent the members’ works or actions. Remember that many of the Saints in Missouri were humble and faithful. However, others had become prideful and disobedient. Read Doctrine and Covenants 97:6–7, and ponder the messages you find in these verses.

Read Doctrine and Covenants 97:8–9, and ponder the messages you find in these verses.

 **3. What did the Lord promise these brethren if they continued to follow Him? In your scripture study journal, write two or three sentences explaining how the description of the tree and its surroundings in verse 9 could encourage you to be more faithful.**

According to Doctrine and Covenants 97:8, what are some characteristics of a person who is accepted of the Lord? To answer this question, write words that complete this principle: **To be accepted of the Lord we must** \_\_\_\_\_

 **4. Answer the following question in your scripture study journal: What are some sacrifices you have made in order to “observe [your] covenants” (D&C 97:8)?**

Ponder your standing before the Lord. Think about how you can apply the principle in Doctrine and Covenants 97:8.

## Doctrine and Covenants 97:10–21

*The Lord emphasizes His will that the Saints in Zion build a temple*

Read Doctrine and Covenants 97:10–12, looking for the sacrifice the Lord required of the Saints in Zion (Missouri). In these verses the word *tithing* refers to offerings generally, not to 10 percent of a person’s annual increase, as understood in the law of tithing, which was revealed later (see D&C 119). More than one-tenth of the Saints’ resources would have been needed to build the temple, including their offerings of time and labor.

Remember that the Lord had designated the lot for the temple in Zion two years before He gave this revelation (see D&C 57:1–3). In June 1833, the Prophet Joseph Smith wrote to Church leaders in Missouri and instructed them to begin construction of the temple immediately (see *History of the Church*, 1:363). However, when the revelation in Doctrine and Covenants 97 was given, on August 2, 1833, the Saints in Missouri had not begun the construction.

### Applying What You Learn

President Marion G. Romney of the First Presidency taught: “Learning the gospel from the written word . . . is not enough. It must also be lived. . . . One cannot fully learn the gospel without living it” (“Records of Great Worth,” *Ensign*, Sept. 1980, 4). In several places in this lesson, you will be encouraged to apply what you have learned. Application should always be part of your gospel study.

Search Doctrine and Covenants 97:12–14, and identify reasons the Lord wanted the Saints in Missouri to build a temple.

How has the temple been “a place of thanksgiving” (D&C 97:13) for you? How has it been “a place of instruction” (D&C 97:13)?

As you study Doctrine and Covenants 97:15–20, look for promises the Lord gave the Saints if they would build a temple.



Elder David B. Haight of the Quorum of the Twelve Apostles explained that the promise of seeing God in the temple (see verses 15–16) may include more than seeing Him with our natural eyes: “It is true that some have actually seen the Savior, but when one consults the dictionary, he learns that there are many other meanings of the word *see*, such as coming to know Him, discerning Him, recognizing Him and His work, perceiving His importance, or coming to understand Him” (“Temples and Work Therein,” *Ensign*, Nov. 1990, 61).

According to Doctrine and Covenants 97:15–17, how can you qualify to experience the Lord’s glory and presence in the temple? Mark words or phrases in these verses that teach the principle that **in the temple, God will manifest Himself to those who are pure in heart.**



**5.** Answer the following questions in your scripture study journal:

- a. What do you think it means to be pure in heart?
- b. What can we do to purify our hearts so we can receive the blessings of the temple?
- c. How have you felt blessed as you have prepared yourself to go to the temple?



Read Doctrine and Covenants 97:21, and identify how the Lord defined the word *Zion*. You may want to write or mark the phrase that teaches the following truth in your scriptures: ***Zion is the pure in heart.***

## Doctrine and Covenants 97:22–28

*The Lord explains what we must do to escape His indignation and receive His blessings*

To understand the Lord’s message in Doctrine and Covenants 97:22–24, consider the following information: Whirlwinds occur all over the world. Strong whirlwinds can turn into violent tornadoes that damage everything in their path. Have you ever witnessed a whirlwind or tornado in person or seen video footage of one?

Read Doctrine and Covenants 97:22–24, and identify what the Lord compared to a whirlwind.

In verse 22, the word *vengeance* refers to the consequences of disobeying the Lord. In the space provided, write about how the Lord’s vengeance might be like a whirlwind: \_\_\_\_\_

Search Doctrine and Covenants 97:25–28 to discover what we need to do to escape the Lord’s vengeance and receive His blessings. You may want to mark the word *if* wherever it occurs in these verses.

Consider how the Lord’s message in verses 25–28 relates to the images of the two types of trees you studied earlier. What do verses 27–28 teach about repentance and forgiveness?

From these verses we learn the principle that **if we are obedient, we will escape the vengeance of the Lord and receive a multiplicity of His blessings.**

Consider what you have felt prompted to do as you have studied Doctrine and Covenants 97. Act on those promptings so you can receive the Lord’s blessings.



**6.** Write the following at the bottom of today’s assignments in your scripture study journal:

*I have studied Doctrine and Covenants 97 and completed this lesson on (date).*

*Additional questions, thoughts, and insights I would like to share with my teacher:*

# Doctrine and Covenants 98

## Introduction

On July 20, 1833, a group of 400–500 Missourians demanded that no more Saints move to Jackson County and that those already living there must leave. Before the Saints in Missouri could respond, a mob began destroying their property and threatening their lives. On August 6, 1833, the Prophet Joseph Smith received the revelation recorded in Doctrine and Covenants 98, in which the Lord instructed the Saints about how to respond to persecution. Although some news of the trouble in Missouri had probably reached the Prophet in Kirtland, Ohio, about 900 miles (1,450 kilometers) away, he could have understood the seriousness of the situation only through revelation. In this revelation the Lord acknowledged the Saints’ afflictions, counseled them to follow the constitutional law of the land, and instructed them to keep their covenants.

## Doctrine and Covenants 98:1–22

*The Lord counsels the Saints to keep their covenants during difficult times*

In Doctrine and Covenants 98:1–22, the Lord counseled the afflicted Saints to give thanks in all things and to wait patiently on the Lord.

Read Doctrine and Covenants 98:11–12, and find the commandment the Lord gave the Saints.

Read Doctrine and Covenants 98:13–15, looking for what the Lord told the Saints about being tested or proved. From these verses we learn that **we prove ourselves to the Lord by keeping our covenants, even when it is difficult to do so.**

Think about why it might have been important for the Saints living in Missouri in 1833 to remember the importance of keeping their covenants even when it was difficult to do so. Why do you think it might be important for us today to remember the importance of keeping our covenants during difficult times?

## Doctrine and Covenants 98:23–32

*The Lord reveals how the Saints are to respond to persecution*



1. Draw three columns in your scripture study journal. Title the first column *The Lord’s Law on Retaliation* (D&C 98:23–32), the second column *The Lord’s Law on War* (D&C 98:33–38), and the third column *The Lord’s Law on Forgiveness* (D&C 98:39–48). Leave room in each column to write the principles and doctrines you discover as you study this lesson. As you work through the lesson, you will find instructions regarding what to write in these columns.

How would you feel if someone harmed you or your family? Why do you think some people might want to retaliate (get revenge) against a person who caused them harm?

Read Doctrine and Covenants 98:23–27, looking for what the Lord said about revenge and retaliation.

You might want to mark the phrases “revile not” and “bear it patiently” in these verses.

Based on what the Lord taught the Saints in Missouri, we learn that **if we bear mistreatment patiently and without retaliating, then the Lord will reward us.** Write this principle in your scripture study journal under the heading “The Lord’s Law on Retaliation.”



2. Answer the following questions in your scripture study journal:

- In what ways do you think retaliation or seeking revenge is harmful?
- Think about someone you know (or have read about) who has shown patience while enduring mistreatment and did not seek revenge. What did this person do to show his or her patience despite being mistreated?

When the mob formed in Jackson County, Missouri, on Saturday, July 20, 1833, they not only destroyed property, they also sought to harm the Church leaders. The following account shows how Bishop Edward Partridge and Charles Allen, a 27-year-old recent convert from Pennsylvania, responded to being mistreated by the mobs in Missouri.



Modern-day photograph of the public square in Independence, Missouri, near where Bishop Edward Partridge and Charles Allen were abused by a mob

“The mob caught Bishop Edward Partridge and Charles Allen, and dragged them through the maddened crowd, which insulted and abused them along the road to the public square. Here two alternatives were presented them; either they must renounce their faith in the *Book of Mormon* or leave the county. The *Book of Mormon* they would not deny, nor consent to leave the county. Bishop Partridge, being permitted to speak, said that the saints had to suffer persecution in all ages of the world, and that he was willing to suffer for the sake of Christ, as the saints in former ages had done; that he had done nothing which ought to offend anyone, and that if they abused him, they would injure an innocent man. Here his voice was drowned by the tumult of the crowd, many of whom were shouting: ‘Call upon your God to deliver you . . . !’ The two brethren, Partridge and Allen, were stripped of their clothing, and bedaubed [smeared] with tar, mixed with lime, or pearl-ash, or some other flesh-eating acid, and a quantity of feathers scattered over them. They bore this cruel indignity and abuse with so much resignation and meekness that the crowd grew still, and appeared astonished at what they witnessed. The brethren were permitted to retire in silence” (B. H. Roberts, *A Comprehensive History of the Church*, 1:333; see also *Church History in the Fulness of Times Student Manual*, 2nd ed. [Church Educational System manual], 2003, 133).



**3.** Answer the following questions in your scripture study journal:

- a. What impresses you about how Bishop Partridge and Charles Allen responded to the persecution they experienced?
- b. What can you do to better follow the Lord’s counsel in this area?

In Doctrine and Covenants 98:28–32, the Lord counseled the Saints that if an enemy had harmed them three times without incurring the vengeance of God, they should warn the enemy in the name of the Lord not to harm them again. The Lord further explained that if the enemy continued to harm them after this warning, then the Saints were justified in “reward[ing] him according to his works” (D&C 98:31). However, the Saints were also told that if they spared their enemies even though they were justified in retaliating, they would be rewarded for their righteousness.

## Doctrine and Covenants 98:33–38

### *The Savior explains when war is justified*

Do you have any relatives or friends who have served in a war for their country? Have you wondered what the Lord has taught about war?

Read Doctrine and Covenants 98:33–34, looking for what the Lord told His ancient followers about war.

Based on what you read in verse 33, fill in the blanks to complete the following phrase: They should \_\_\_\_\_ go to battle against any nation, kindred, tongue, or people, \_\_\_\_\_ the Lord \_\_\_\_\_ them. You may want to write this truth in your scripture study journal under the heading “The Lord’s Law on War.” (Remember that the Lord gave this law specifically to people who lived in a different time and in a different culture. Although the principle of the law is true, today we are also subject to the laws of the nations in which we live [see Articles of Faith 1:12].)

According to Doctrine and Covenants 98:34, what were those ancient followers supposed to do first if someone declared war against them? (Write your answer to this question in your scripture study journal under the heading “The Lord’s Law on War.”)

Read Doctrine and Covenants 98:35–38, looking for what the Lord told His ancient followers to do if their offer of peace was not accepted.

From these verses we learn that **war can be justified under circumstances prescribed by the Lord**. Write this truth in your scripture study journal under the heading “The Lord’s Law on War.”



When many nations were engaged in battle during World War II, President David O. McKay explained the circumstances in which the Lord's followers are justified in entering war:



"War is incompatible with Christ's teachings. The gospel of Jesus Christ is the gospel of peace. War is its antithesis [opposite] and produces hate. . . .

"There are, however, two conditions which may justify a truly Christian man to enter—mind you, I say *enter*, not *begin*—a war: (1) An attempt [by someone] to dominate and deprive another of his free agency, and, (2) Loyalty to his country. Possibly there is a third, [namely], Defense of a weak nation that is being unjustly crushed by a strong, ruthless one" (in Conference Report, Apr. 1942, 71–72).

## Doctrine and Covenants 98:39–48

### *The Lord teaches the Saints how they should respond to their enemies*

Related to the Lord's law on war is the Lord's law of forgiveness in Doctrine and Covenants 98:39–48. The following account of an event that took place after World War II demonstrates the Lord's law on forgiveness:

"In Holland during World War II, the Casper ten Boom family used their home as a hiding place for those hunted by the Nazis. This was their way of living out their Christian faith. Four members of the family lost their lives for providing this refuge. Corrie ten Boom and her sister Betsie spent horrific months in the infamous Ravensbrück concentration camp. Betsie died there—Corrie survived.

"In Ravensbrück, Corrie and Betsie learned that God helps us to forgive. Following the war, Corrie was determined to share this message. On one occasion, she had just spoken to a group of people in Germany suffering from the ravages of war. Her message was 'God forgives.' It was then that Corrie ten Boom's faithfulness brought forth its blessing.

"A man approached her. She recognized him as one of the cruelest guards in the camp. 'You mentioned Ravensbrück in your talk,' he said. 'I was a guard there. . . . But since that time, . . . I have become a Christian.' He explained that he had sought God's forgiveness for the cruel things he had done. He extended his hand and asked, 'Will you forgive me?'

"Corrie ten Boom then said:

"'It could not have been many seconds that he stood there—hand held out—but to me it seemed hours as I wrestled with the most difficult thing I had ever had to do.

"'. . . The message that God forgives has a . . . condition: that we forgive those who have injured us. . . .

"'. . . "Help me!" I prayed silently. "I can lift my hand. I can do that much. You supply the feeling."

"'. . . Woodenly, mechanically, I thrust my hand into the one stretched out to me. As I did, an incredible thing took place. The current started in my shoulder, raced down my arm, sprang into our joined hands. And then this healing warmth seemed to flood my whole being, bringing tears to my eyes.

"'"I forgive you, brother!" I cried. "With all my heart."

"'For a long moment we grasped each other's hands, the former guard and the former prisoner. I had never known God's love so intensely, as I did then.' [Corrie ten Boom, *Tramp for the Lord* (1974), 54–55.]" (Keith B. McMullin, "Our Path of Duty," *Ensign* or *Liahona*, May 2010, 13).

What does this story teach you about forgiveness?

Read Doctrine and Covenants 98:39–40, looking for the Lord's law on forgiveness.

According to these verses, what should we do when someone asks for our forgiveness?

The phrase "until seventy times seven" in verse 40 implies that we should forgive others as many times as they repent and seek our forgiveness after offending or hurting us. (Although we are commanded to forgive, this does not mean that we should allow others to continue harming us.)

Read Doctrine and Covenants 98:41–43, searching for additional truths the Lord taught the Saints concerning their enemies who trespass against them and do not repent.

Write a summary of the Lord's law on forgiveness in your scripture study journal under the heading "The Lord's Law on Forgiveness."



**4.** Answer the following questions in your scripture study journal:

- Why do you think we are commanded to forgive others even if they don't ask for forgiveness?
- Why are we commanded to forgive our enemies?

Think about what you can do in your life to follow the Lord's law on forgiveness.

In Doctrine and Covenants 98:44–48, the Lord promised that if the Saints' enemies would repent, they would escape His vengeance.

 **5.** Write the following at the bottom of today's assignments in your scripture study journal:

*I have studied Doctrine and Covenants 98 and completed this lesson on (date).*

*Additional questions, thoughts, and insights I would like to share with my teacher:*

## UNIT 21: DAY 2

# Doctrine and Covenants 99–100

### Introduction

The Prophet Joseph Smith received the revelation recorded in Doctrine and Covenants 99 on August 29, 1832. In this revelation the Lord called John Murdock to continue his missionary labors and go to the eastern United States. Joseph Smith received the revelation recorded in Doctrine and Covenants 100 on October 12, 1833, while he and Sidney Rigdon were in New York laboring as missionaries. In this revelation the Lord assured Joseph and Sidney that their families in Ohio were well. The Lord also comforted Joseph concerning the Saints in Missouri who were suffering persecution.

### Doctrine and Covenants 99

#### *The Lord calls John Murdock to proclaim the gospel*

Imagine that a friend who is not a member of the Church asks you why so many young men and women are willing to give up 2 years or 18 months of their lives to serve missions. How would you explain why someone would be willing to make such a sacrifice to serve a mission?



John Murdock was an early Church member. As you read the following information, notice the sacrifices he made to serve the Lord:

John Murdock investigated many churches and concluded that all religions had lost their way. However, in late 1830, he read the Book of Mormon and felt the Holy Ghost bear witness of its truth. He was convinced he had found Christ's true Church. Shortly after his baptism on November 5, 1830, John Murdock served a mission, baptizing about 70 people in four months in Orange and Warrensville, Ohio.



John Murdock

On April 30, 1831, shortly after John returned from his mission, his wife, Julia, died after giving birth to twins. In June 1831, the Lord called him to go to Missouri and preach the gospel along the way (see D&C 52:8–9). Before John could go, he needed to make sure his five children, all under the age of seven, were provided for. He arranged for several individuals to watch over his older children, and Joseph and Emma Smith adopted the infant twins. For the rest of 1831 and the first half of 1832, John Murdock preached in Michigan Territory, Indiana, Missouri, and Ohio. When he returned to Hiram, Ohio, in June 1832, he was suffering from the effects of a long illness. He also learned that one of his twins had died the previous March and that those who had cared for his three older children demanded payment for their help.

The Prophet Joseph Smith received the revelation in Doctrine and Covenants 99 approximately two months after John Murdock arrived home from his second mission. Read Doctrine and Covenants 99:1, looking for what the Lord called John Murdock to do.

In addition to this call to preach the gospel, this revelation contains numerous promises relating to John's service. Read Doctrine and Covenants 99:2–3, looking for how both John Murdock and those he taught would be blessed by his service.

From verses 2–3 we learn the following truths: **We represent the Lord when we serve missions, and those who receive the gospel as little children obtain mercy.**

Before John Murdock left on his mission to the eastern states, he had an experience in the School of the Prophets that had a profound effect on him. "In one of [our prayer meetings] the Prophet told us if we could humble ourselves before God, and exercise strong faith, we should see the face of the Lord. And about midday the visions of my mind were opened, and the eyes of my understanding were enlightened, and I saw the form of a man, most lovely, the visage of his face was sound and fair as the sun. . . . His countenance was most penetrating, and yet most lovely. And while I was endeavoring to comprehend the whole personage from head to feet it slipped from me and the vision was closed up. But it left on my mind the impression of love, for months, that I never felt before to that degree" (John Murdock, autobiography and diary, 13, L. Tom Perry Special Collections, Harold B. Lee Library, Brigham Young University, Provo, Utah).



**1. Identify at least three people in the scriptures or in your life who made sacrifices to serve the Lord. Write their names in your scripture study journal. Then write what blessings these people received because of their sacrifices and service.**

Read Doctrine and Covenants 99:4–5, looking for what the Lord said would happen to those who rejected the message John Murdock would teach them.

Read Doctrine and Covenants 99:6–8, looking for evidence that the Lord was aware of John Murdock's needs and the sacrifices he was making.

John Murdock followed the Lord's counsel and made arrangements to send his three oldest children to Bishop Partridge in Missouri, where they stayed

with different families. John left on his mission in September 1832, about one month after he received his call. He served several more missions, and then he joined his older children in Missouri. For the remainder of his life, John Murdock served the Lord faithfully in his callings as a missionary, a bishop, and a patriarch.

## Doctrine and Covenants 100:1–12

*The Lord gives Joseph Smith and Sidney Rigdon words of comfort and instruction*

What are some of the concerns missionaries might have as they begin their missions? Keep these concerns in mind while studying Doctrine and Covenants 100.

In April 1833 a man named Freeman Nickerson joined the Church in New York and traveled to Kirtland, Ohio. When Freeman met Joseph Smith, he asked the Prophet to visit the Nickerson family in New York and Canada. Joseph Smith and Sidney Rigdon agreed to his proposal, and they left Kirtland with him on October 5, 1833. The group preached the gospel while traveling. On October 12, 1833, they arrived at the Nickerson home in Perrysburg, New York, and Joseph received the revelation recorded in Doctrine and Covenants 100.

Read the section introduction for Doctrine and Covenants 100, looking for what Joseph Smith and Sidney Rigdon were concerned about when they arrived in New York.

In this revelation the Lord responded to Joseph Smith and Sidney Rigdon's concerns for their families. Read Doctrine and Covenants 100:1–2, looking for how the Savior responded to their concerns. You may want to mark the phrases that might have been comforting to Joseph and Sidney.



**2. In your scripture study journal, describe how the Lord's words in Doctrine and Covenants 100:1–2 might help missionaries today with their concerns regarding their families.**

In addition to reassuring them about their families, the Lord also assured Joseph and Sidney that they would be blessed in their missionary labors. Read Doctrine and Covenants 100:3–4, and identify some of these assurances.

Read Doctrine and Covenants 100:5–8, looking for additional promises from the Lord.



If we will lift up our voices to share the gospel, then the Lord will help us know what to say.

Verses 5–6 contain the promise that **if we will lift up our voices to share the gospel, then the Lord will help us know what to say.** (Remember that to receive this promised help, we must live righteously and prepare ourselves to serve.)

In Doctrine and Covenants 100:7, we learn that the missionaries should declare the gospel “in solemnity of heart, in the spirit of meekness.” This counsel implies that we should share the gospel with seriousness and humility.

Read Doctrine and Covenants 100:8, looking for what the Lord promised if we preach the gospel in this way. Then complete the following principle: **If we share the gospel with others in solemnity of heart and in the spirit of meekness, then the Holy Ghost will**

 **3.** Ponder a time when you felt the Spirit confirm that something you taught or said was right. This might include talking about the gospel with your friends or family, bearing your testimony or giving a talk in a Church meeting, or making a comment in a class. In your scripture study journal, describe your experience. You could also describe an experience when you felt the Holy Ghost bear witness that what someone else was saying was true.

Read Doctrine and Covenants 100:9–12, looking for instructions and promises the Lord gave the Prophet Joseph Smith and Sidney Rigdon.

 **4.** Answer the following question in your scripture study journal: What might the promise in Doctrine and Covenants 100:12 mean to you if you were serving a mission?

The missionary efforts of the Prophet Joseph Smith and Sidney Rigdon had a lasting influence on the Church. Sidney Rigdon preached to a large group gathered at the Nickerson home in New York, and the three brethren then continued north to Ontario, Canada, where they preached to additional groups. The missionaries baptized nearly 20 individuals there and organized a branch of the Church. Some time later, Parley P. Pratt visited this branch as he served a mission in Canada. Moses Nickerson, a convert from the 1833 mission, introduced Elder Pratt to John Taylor, who became a successful missionary and later became President of the Church. These events were a partial fulfillment of the Lord’s promise that “an effectual door [would] be opened in the regions round about in this eastern land” (D&C 100:3).

### Doctrine and Covenants 100:13–17

#### *The Lord comforts Joseph and Sidney concerning the trials of the Saints in Missouri*

In August 1833, shortly before the Prophet Joseph Smith departed on this mission, Oliver Cowdery had brought word from Missouri that enemies of the Church had turned violent against the Latter-day Saints there. Joseph sent Orson Hyde and John Gould to deliver counsel from him to the Saints in Missouri. This journey would be hazardous because they would be traveling through areas near anti-Mormon mobs. While on his mission with Sidney Rigdon and Freeman Nickerson, the Prophet worried about Orson and John and all of the Saints who were being persecuted in Missouri.

 **5.** Read Doctrine and Covenants 100:13–17, looking for what the Lord told the Prophet Joseph Smith. In your scripture study journal, complete the following assignments:

- Based on what you learn in verse 15, complete this principle:  
***All things will work together for our good if we . . .***
- To “walk uprightly” before the Lord refers to being righteous and keeping the commandments. Think of specific things you can do in your life to better “walk uprightly” before the Lord. Set and write a goal to act on one of these things and more fully invite this blessing into your life.

 **6.** Write the following at the bottom of today’s assignments in your scripture study journal:

*I have studied Doctrine and Covenants 99–100 and completed this lesson on (date).*

*Additional questions, thoughts, and insights I would like to share with my teacher:*



## UNIT 21: DAY 3

# Doctrine and Covenants 101:1–16

## Introduction

On December 16 and 17, 1833, the Prophet Joseph Smith received a revelation concerning the afflictions the Saints were experiencing in Missouri. This revelation, recorded in Doctrine and Covenants 101, will be covered in three lessons. This first lesson includes the Lord’s explanation of why He allowed the Saints to be afflicted. It also includes His words of counsel and comfort to the suffering Saints.

## Doctrine and Covenants 101:1–8

*The Lord explains why He allows His people to experience trials*

From what you learned during your study of Doctrine and Covenants 98, indicate which of the following difficulties the Saints experienced in Jackson County, Missouri, in July 1833. You can refer to the lesson from day 1 to help you remember.

The Saints’ printing office was destroyed.
Sidney Gilbert’s store was demolished, and the goods were stolen.
Many of the Saints’ homes and crops were burned down.
Two of the Saints, Edward Partridge and Charles Allen, were tarred and feathered in a public square.

Due to the mob violence in Jackson County, Missouri, in July 1833, Church leaders agreed to leave the county. However, in August 1833, the Prophet Joseph Smith counseled the Saints not to sell any of their land there. Church leaders petitioned the government and used available legal channels to maintain their lands in Missouri and seek justice for those responsible for the violence. After hearing of these actions, and believing that the Saints were not planning

### Learning about the Geographic Setting

Simple information about the geographic settings of scripture accounts can help you better understand the context and content of the scriptures. Maps can help you understand the relationship between various locations.



to leave as expected, non-Latter-day Saint settlers attacked the Saints again. On the night of October 31, 1833, a mob of about 50 horsemen raided the Whitmer Settlement, west of Independence. They unroofed 13 houses and whipped several men, almost killing them. These attacks continued for the next two nights in Independence and other places where the Saints lived. Men were beaten, and women and children were terrorized. More than 1,000 Saints were driven from their homes in Jackson County.

What questions do you think the Saints in Missouri might have had at this time? Have you ever wondered why the Lord allows bad things to happen to you or people you know?

Read the section introduction to Doctrine and Covenants 101 to learn when this revelation was given and some further trials the Saints in Missouri faced at this time.

When the Saints in Missouri were suffering through these trials, the Lord revealed truths about why He allows His people to experience afflictions. Read Doctrine and Covenants 101:1–2, looking for a reason why the Lord allowed the Saints in Jackson County to suffer persecution and affliction.

From verse 2 we learn that **when we violate the commandments, God allows us to suffer.**

 **1.** Answer the following question in your scripture study journal: Why do you think it is important to understand this truth?

Although many Saints in Missouri were faithful and obedient, they still suffered because of persecution. Read Doctrine and Covenants 101:3–5, looking for a reason why the Lord allows even the righteous Saints to be afflicted. Note that the word *chasten* means to discipline or correct, that the word *try* means to test, and that the word *sanctify* means to make someone or something pure or holy.

Refer to verse 5 to complete the following statement of truth: **If we will not endure chastening, we cannot be \_\_\_\_\_.**



Elder D. Todd Christofferson of the Quorum of the Twelve Apostles taught how being chastened and tested helps us become sanctified: “In addition to stimulating our repentance, the very experience of enduring chastening can refine us and prepare us for greater spiritual privileges” (“As Many as I Love, I Rebuke and Chasten,” *Ensign* or *Liahona*, May 2011, 98).



In Doctrine and Covenants 101:4, the Lord referred to Abraham as an example of someone who was chastened and tried. When the Lord commanded Abraham to offer his son Isaac as a sacrifice, Abraham proved his faithfulness and showed that he was prepared to receive great spiritual blessings (see Genesis 22:1–18).

 **2.** Answer the following question in your scripture study journal: How can understanding the truth taught in Doctrine and Covenants 101:5 help you during difficult times?

 **3.** Read Doctrine and Covenants 101:6–8, and identify specific things some of the Saints in Missouri did that caused afflictions to come upon them. Then answer the following questions in your scripture study journal:

- a. According to verse 7, what is the consequence of being “slow to hearken unto the voice of the Lord”?
- b. According to verse 8, what do some people begin to do during times of affliction? What do you think it means to “feel after” the Lord?

Ponder an experience when you have felt chastened and you sought the Lord.

## Doctrine and Covenants 101:9–16

### *The Lord counsels and comforts the Saints*

As you read Doctrine and Covenants 101:9, look for a message of hope the Lord gave to the Saints who were suffering in Missouri. You may want to mark words or phrases that teach the following doctrine: **Even when we have sinned, the Lord will have compassion toward us.**

 **4.** Answer the following question in your scripture study journal: How can understanding this doctrine bring you hope?

In Doctrine and Covenants 101:10–11, we learn that even though the Lord allowed the Saints to be persecuted, He said that He would punish the people who persecuted them.



As you read the following paragraphs, mark the descriptions of suffering that would have been especially difficult for you to witness or experience:

The mob in Jackson County, Missouri, continued tormenting the Saints until all members of the Church were driven out of the county. Lyman Wight reported, “I saw one hundred and ninety women and children driven thirty miles across the prairie, with three decrepit men only in their company, in the month of November, the ground thinly crusted with sleet; and I could easily follow on their trail by the *blood that flowed from their lacerated feet* on the stubble of the burnt prairie!” (in *History of the Church*, 3:439).

Most of the Saints fled north, where they had to cross the Missouri River. The shores of the river near the ferry were lined with refugees on both sides. Some were fortunate enough to escape with their household goods, but many lost everything. Parley P. Pratt wrote: “Hundreds of people were seen in every direction, some in tents and some in the open air around their fires, while the rain descended in torrents. Husbands were inquiring for their wives, wives for their husbands; parents for children, and children for parents. . . . The scene was indescribable, and, I am sure, would have melted the hearts of any people on the earth, except our blind oppressors, and a blind and ignorant community” (*Autobiography of Parley P. Pratt*, ed. Parley P. Pratt Jr. [1938], 102).

How do you think you might respond if you experienced such afflictions?

Read Doctrine and Covenants 101:12–16, looking for the Lord’s promises to the righteous Saints. (It may help you to know that in verse 12, the phrase “all mine Israel” refers to those who are true to the gospel covenant.)

You may want to write the following principle in your scriptures near Doctrine and Covenants 101:16: ***When we live righteously, we can find comfort in the knowledge that all people are in the Lord’s hands.***

 **5.** In your scripture study journal, answer the following questions based on your own experience, or you could discuss these questions with a family member or friend and write what you learn from the conversation:

- a. In Doctrine and Covenants 101:16, what do you think is the meaning of the command to “be still and know that I am God”?
- b. When have you felt blessed with peace during a difficult time?
- c. How can being still, or quiet, help you receive comfort from the Lord?

 **6.** Write the following at the bottom of today’s assignments in your scripture study journal:

*I have studied Doctrine and Covenants 101:1–16 and completed this lesson on (date).*

*Additional questions, thoughts, and insights I would like to share with my teacher:*

## UNIT 21: DAY 4

# Doctrine and Covenants 101:17–42

### Introduction

On December 16 and 17, 1833, the Prophet Joseph Smith received a revelation concerning the Saints in Missouri who had to flee from their homes to escape severe persecution. Many of those Saints had been forced to leave all their possessions behind. The revelation that the Prophet received, recorded in Doctrine and Covenants 101, is covered in three lessons. This second lesson includes the Lord’s description of conditions during the Millennium. It also includes words of comfort and counsel to the Saints in Missouri.

## Doctrine and Covenants 101:17–34

### *The Lord describes conditions during the Millennium*

Think of some future events you are preparing for. Why do you put forth the effort to be prepared for those events?

Doctrine and Covenants 101 contains instructions on preparing for the Second Coming of Jesus Christ and the Millennium (the period of peace that will begin when Christ returns to reign personally on the earth). From Doctrine and Covenants 101:17–21, we learn that the Lord’s promise to gather the Saints in the city of Zion in Jackson County, Missouri, “is held in abeyance [temporarily suspended], while the people are being sanctified for the great gift and for the responsibilities associated with it. In the meantime the honest in heart are gathering to the valleys of the Rocky Mountains [and to stakes all around the world]. . . . Temples have been erected. . . . But Zion shall yet be established on the chosen site” (James E. Talmage, *Articles of Faith*, 12th ed. [1924], 353).

Read Doctrine and Covenants 101:22–23, looking for something the Lord told the Saints to do to prepare for His Second Coming. (In verse 23, the phrase “the revelation which is to come” refers to the Second Coming of Jesus Christ. The reference to the removal of a veil is also related to the Second Coming—to the time when all the inhabitants of the earth will see the Savior.)



Complete the following statement based on Doctrine and Covenants 101:22–23: We can prepare for the Savior’s Second Coming by \_\_\_\_\_ on His name, living according to gospel principles, \_\_\_\_\_ together, and \_\_\_\_\_ in holy places.



**1.** Answer the following questions in your scripture study journal:

- When have you felt that you were in a holy place?
- How does gathering in holy places with other Latter-day Saints help you prepare for the Lord’s Second Coming?

Doctrine and Covenants 101:24–34 refers to the destruction of the wicked at the time of Jesus Christ’s Second Coming and to conditions that will exist on the earth during the Millennium. For example, in verses 32–34 we read that the Lord will reveal hidden things about the earth, such as its creation and about the heavens. (The word *enmity* in verse 26 refers to hatred or hostility.)



**2.** In your scripture study journal, list two or three of the conditions in Doctrine and Covenants 101:24–34 that you would be particularly excited to experience. Explain why these conditions would be meaningful to you.

## Doctrine and Covenants 101:35–38

### *The Lord assures the Saints in Missouri that if they endure in faith, they will ultimately partake of His glory*

When the Lord gave the revelation recorded in Doctrine and Covenants 101:24–34, the Saints in Missouri had experienced tremendous difficulties, including physical abuse, the loss of their homes and possessions, and cold weather conditions.

Read Doctrine and Covenants 101:35–38, and identify principles and counsel the Lord gave the Saints in Missouri to comfort and strengthen them in their trials.



**3.** In your scripture study journal, write one item of counsel the Lord gave the Saints in verses 35–38. Then explain how this counsel could comfort the Saints in Missouri.

Complete the following principle based on what you have learned from Doctrine and Covenants 101:35:

**Those who \_\_\_\_\_ for the name of the Savior and \_\_\_\_\_ will partake of God’s glory.**

True disciples of Jesus Christ always follow Him, even when they are persecuted for their faith. President James E. Faust of the First Presidency shared the following account about two Latter-day Saints who



lived in Mexico in the early 1900s. In 1915 they were captured by a violent band of soldiers. As you read the account, notice how these two Latter-day Saints were examples of enduring persecution in faith.

“Rafael Monroy was the president of the small San Marcos Mexico Branch, and Vicente Morales was his first counselor. . . . They were told they would be spared if they would give up their weapons and renounce their strange religion. Brother Monroy told his captors that he did not have any weapons and simply drew from his pocket his Bible and Book of Mormon. He said, ‘Gentlemen, these are the only arms I ever carry; they are the arms of truth against error.’

“When no arms were found, the brethren were cruelly tortured to make them divulge where arms were hidden. But there were no arms. They were then taken under guard to the outskirts of the little town, where their captors stood them up by a large ash tree in front of a firing squad. The officer in charge offered them freedom if they would forsake their religion and join the [soldiers], but Brother Monroy replied, ‘My religion is dearer to me than my life, and I cannot forsake it.’

“They were then told that they were to be shot and asked if they had any request to make. Brother Rafael requested that he be permitted to pray before he was executed. There, in the presence of his executioners, he knelt down and, in a voice that all could hear, prayed that God would bless and protect his loved ones and care for the little struggling branch that would be left without a leader. As he finished his prayer, he used the words of the Savior when He hung upon the cross and prayed for his executioners: ‘Father, forgive them; for they know not what they do.’ [Luke 23:34.] With that the firing squad shot both Brother Monroy and Brother Morales” (“Discipleship,” *Ensign* or *Liahona*, Nov. 2006, 21–22; based on Rey L. Pratt, “A Latter-day Martyr,” *Improvement Era*, June 1918, 720–26).

Think of times when you have been persecuted (teased or bullied) because of your faith in Jesus Christ and His Church.



**4.** Answer the following question in your scripture study journal: When people are persecuted for their faith in Jesus Christ and His Church, how can they respond with faith?



Think about some of the uses of salt. For example, it can be used to flavor and preserve food and to heal wounds as a disinfectant. Read Doctrine and Covenants 101:39, and identify the people the Lord compared to salt.

Ponder why people who come unto the gospel and make covenants with the Lord might be called “the salt of the earth.”

Notice in verse 39 that the Lord also called Church members “the savor of men.” The word *savor* refers to distinctive flavor or quality. What do you think it means to be the savor of men?

The following statement by Elder Carlos E. Asay of the Seventy can help you better understand what it means to be the savor of men: “When the Lord used the expression ‘savor of men,’ he was speaking of those who represent him. He was referring to those who have repented, who have been washed clean in the waters of baptism, and who have covenanted to take upon them his name and his cause. Moreover, he was speaking of those who would share by covenant his priesthood power. He was speaking of you and me” (“Salt of the Earth: Savor of Men and Saviors of Men,” *Ensign*, May 1980, 42).

The phrases “salt of the earth” and “savor of men” teach that as members of the Church of Jesus Christ, we have a responsibility to help all the people of the earth receive God’s blessings (see Abraham 2:8–11).

Study Doctrine and Covenants 101:40–42, looking for the Lord’s warnings and promises.



Note that verse 40 includes the phrase “if that salt of the earth lose its savor.” Salt does not lose its savor as it gets older. It loses its savor when it is mixed with other substances and contaminated by them. Elder Asay taught: “Flavor and quality flee a man when he contaminates his mind with unclean thoughts, desecrates his mouth by speaking less than the truth, and misapplies his strength in performing evil acts” (“Salt of the Earth,” 42).

Doctrine and Covenants 101:40–42 help us learn that **to help the people of the earth receive God’s blessings, we must repent of our sins and be humble.** You may want to write this truth in your scriptures.

 **5.** Answer the following questions in your scripture study journal:

- How do the Lord’s teachings in Doctrine and Covenants 101:39–42 help you understand what He expects of you?
- What are some examples of how sin can prevent us from blessing the people of the earth?
- What will you do to avoid being contaminated by sin?

Think about whether sins are contaminating your life. Repent of those sins so you can become pure before the Lord and so you can be more effective in helping others receive His blessings.

 **6.** Write the following at the bottom of today’s assignments in your scripture study journal:

*I have studied Doctrine and Covenants 101:17–42 and completed this lesson on (date).*

*Additional questions, thoughts, and insights I would like to share with my teacher:*

## UNIT 22: DAY 1

# Doctrine and Covenants 101:43–101; 102

## Introduction

On December 16 and 17, 1833, the Prophet Joseph Smith received a revelation concerning the Saints in Missouri who had left their homes to escape persecution. Many of those Saints had been forced to leave all their possessions behind. The revelation that the Prophet received, recorded in Doctrine and Covenants 101, is covered in three lessons. This third lesson includes the Lord’s parable of the nobleman and the olive trees, teaching His will concerning the redemption of Zion. It also includes the Lord’s counsel that the Saints continue gathering together and seek justice for those who had crimes committed against them.

## Doctrine and Covenants 101:43–62

*The Lord gives the parable of the nobleman and the olive trees*

A parable is “a simple story used to illustrate and teach a spiritual truth or principle. A parable is based on comparing an ordinary object or event to a truth” (Guide to the Scriptures, “Parable”; scriptures.lds.org). You probably remember parables the Savior taught during His mortal ministry—the parable of the good Samaritan, the parable of the prodigal son, the parable of the ten virgins, and others.

In today’s lesson, you will study the parable of the nobleman and the olive trees, a parable the Savior gave through the Prophet Joseph Smith.



As you study this parable, consider the following statement by Elder Dallin H. Oaks of the Quorum of the Twelve Apostles: “[The Savior’s] parables had multiple meanings or applications according to the spiritual maturity of the listener. They had a message for both children and gospel scholars” (“Scripture Reading and Revelation,” *Ensign*, Jan. 1995, 8). Look for multiple meanings and applications in this parable (see also Bible Dictionary, “Parables”).

The Lord gave the parable of the nobleman and the olive trees to help His people understand His “will concerning the redemption of Zion” (D&C 101:43). Read Doctrine and Covenants 101:44–45, looking for what the nobleman in the parable instructed his servants to do.



Why did the nobleman want watchmen in the vineyard? Why did he want a watchman on the tower?

Read Doctrine and Covenants 101:46–50, and identify how well the servants of the nobleman followed his counsel. (As you read verse 50, it might be helpful to know that the phrase “at variance one with another” means that the servants disagreed with each other or were in conflict with one another.)

Why did the servants fail to build the tower? \_\_\_\_\_

Read Doctrine and Covenants 101:51, looking for what happened because the servants did not build the tower.

Read the nobleman’s words to his servants, in Doctrine and Covenants 101:52–54. According to verse 54, why was the nobleman upset that his servants had not built a tower?

How do the events described in this parable relate to what happened to the Saints in Missouri?

 **1.** Answer the following question in your scripture study journal: How might the tower in the parable relate to the temple that the Saints had failed to build in Jackson County, Missouri?

 **2.** Answer the following question in your scripture study journal: What are some principles in this parable that apply to your life? (As you answer this question, consider the

following doctrines and principles: **When we obey the Lord’s commandments, we are strengthened to withstand spiritual and physical enemies. Prophets serve as watchmen on the tower, warning us of coming dangers. Through temple work, we prepare to withstand the adversary.**)

Read Doctrine and Covenants 101:55, in which the nobleman in the parable gives instructions to one servant. Then read Doctrine and Covenants 103:21. Who does this servant in the parable represent?

Read Doctrine and Covenants 101:56–62, looking for what the nobleman instructed the servant to do because the enemy had destroyed parts of the vineyard. Joseph Smith followed the instruction in this parable. He organized a group called Zion’s Camp to redeem the land of Zion. They arrived in Missouri six months after this parable was given. You will learn more about Zion’s Camp when you study Doctrine and Covenants 103 and 105.

## Doctrine and Covenants 101:63–75

*The Lord admonishes the Saints to continue the work of gathering*

Even though the Saints had been expelled from Jackson County, Missouri, the Lord commanded them to continue to build His kingdom. Read Doctrine and Covenants 101:63–64, looking for what the Lord promised He would continue to do.



In this revelation the Lord referred to the parable of the wheat and the tares, in which He described the gathering of His people (see also Matthew 13:24–30, 36–43). Read Doctrine and Covenants 101:65–66, and find the following elements of the parable: garner, wheat, and tares.





In ancient times, garners were places where wheat was gathered and stored for safety. Elder David A. Bednar of the Quorum of the Twelve Apostles offered one symbolic meaning of the word *garners* in this parable. He said, “The garners are the holy temples” (“Honorably Hold a Name and Standing,” *Ensign* or *Liahona*, May 2009, 97). Tares are weeds that look like wheat when they are young.

To help you understand this parable, you may want to write the following interpretations in your scriptures: *garners = holy temples; wheat = the righteous; tares = the wicked.*

In the parable, wheat is gathered into the garners. In what ways do we gather to the temple?

Fill in the blanks to express a principle this parable teaches: **As we gather to the \_\_\_\_\_, we receive protection and prepare ourselves for \_\_\_\_\_.**

 **3. Answer the following question in your scripture study journal: How do temple ordinances and covenants provide protection for you and prepare you for eternal life?**

In Doctrine and Covenants 101:67–75, we read that even though the Saints had been forced out of Jackson County, Missouri, the Lord counseled them to continue to purchase property there.

### Doctrine and Covenants 101:76–101

*The Lord counsels the Saints to continue to seek a way to return to their homes in Missouri*

In addition to instructing the Saints to purchase property, the Lord told them to “importune for redress” because of the actions of those who had persecuted them (see D&C 101:76). In other words, He told them to seek justice through the government’s legal system. Read Doctrine and Covenants 101:76–80, and identify the system of laws that would allow the Saints to seek help from government leaders.

According to these verses, why does the Lord want the Constitution of the United States to be maintained?

 **4. In Doctrine and Covenants 101:78, notice the phrases “moral agency” and “accountable for his own sins.” Answer the following questions in your scripture study journal:**

- Why is accountability—responsibility for our actions—an important part of agency?
- What would you say to someone who says “I am free to do whatever I want”?

Complete the following doctrine: **God has given us agency, the power to choose, but we are \_\_\_\_\_ for our choices.**

The Lord used a third parable to encourage the Saints to seek help from their government leaders. It is found in Doctrine and Covenants 101:81–84. (Another version of this parable is found in Luke 18:1–8.) As you read Doctrine and Covenants 101:81–84, think about how the parable applied to the Saints in Missouri. As the parable appears in this revelation, the widow represents members of the Church. The judge may represent government leaders whom the Saints would ask for help.

Read Doctrine and Covenants 101:85–88 to see how the Savior applied this parable to the Saints who had been driven from their homes.

The Saints followed the Lord’s admonition. They asked Daniel Dunklin, the governor of Missouri, to provide military protection for them when they returned to their homes. He refused, saying that the law did not authorize him to do such a thing. They also asked Andrew Jackson, the president of the United States, to restore their homes and possessions and ensure their protection, but he did not help them. At the time, officials in the United States government felt that state governments were to handle such issues. The Saints petitioned the Missouri state legislature as well, but those politicians also refused to help.

Scan Doctrine and Covenants 101:89–91, looking for what the Lord said about how government leaders would be held accountable if they refused to help the Saints. Then read Doctrine and Covenants 101:92–95, looking for what the Lord told the Saints to do for their government leaders.

 **5. Answer the following question in your scripture study journal: What does Doctrine and Covenants 101:92 teach you about the Lord?**

As you examine these verses and write about verse 92, take time to ponder the Lord’s love and mercy. Note that He does not want to punish people. He wants all people to repent so He can be merciful to them.

In Doctrine and Covenants 101:96–101, we read the Lord’s counsel to the Saints to retain their properties in Jackson County, even though they were not allowed to live there. These verses also include a promise from the Lord that if the Saints lived worthily, they would someday be able to live there.



## Doctrine and Covenants 102

*The Lord instructs the high council on the proceedings for settling difficult matters*

Doctrine and Covenants 102 contains the Lord's instructions on how stake presidents, assisted by their counselors and members of the high council, are to conduct disciplinary councils for people who have committed serious sins. "The purposes of disciplinary councils are to (1) save the souls of transgressors, (2) protect the innocent, and (3) safeguard the purity, integrity, good name of the Church" (*True to the Faith: A Gospel Reference* [2004], 37–38). The Lord revealed His will to those who preside over disciplinary councils.



6. Write the following at the bottom of today's assignments in your scripture study journal:

*I have studied Doctrine and Covenants 101:43–101; 102 and completed this lesson on (date).*

*Additional questions, thoughts, and insights I would like to share with my teacher:*

### UNIT 22: DAY 2

# Doctrine and Covenants 103

## Introduction

In a meeting of the Kirtland high council on February 24, 1834, Parley P. Pratt and Lyman Wight sought direction from the council regarding how the Saints in Missouri could obtain temporal relief and regain possession of their lands in Jackson County. That same day, the Prophet Joseph Smith received the revelation recorded in Doctrine and Covenants 103, in which the Lord promised that the land of Zion would be redeemed. The Lord directed Church leaders to gather resources and recruits to help the Saints in Missouri. This group came to be known as Zion's Camp.



Zion's Camp arrives in Missouri

## Doctrine and Covenants 103:1–21

*The Lord promises that Zion will be redeemed*

What enemies do the righteous have today?

Think about how the enemies of the Lord are seeking to hinder your spiritual progress and the progress of the Church. As you study Doctrine and Covenants 103, look for doctrines and principles that will help you overcome such enemies.

As explained in the introduction to this lesson, the Lord gave a revelation to the Prophet Joseph Smith in response to questions about how to help the Saints in Missouri. In the beginning of the revelation, the Lord explained why He allowed His enemies to persecute the Saints in Missouri. Read Doctrine and Covenants 103:1–4, looking for reasons why the Lord would permit such terrible things to happen to His people.

Consider why it is significant that the Lord referred to those who were persecuting the Saints as His enemies.

Read Doctrine and Covenants 103:5–7, and search for answers to the following question: If the Saints would follow the Lord's counsel "from [that] very hour," what blessings would they receive? (You may want to mark the answers as you find them. Note that the word *prevail* means to be stronger than an opponent or to be victorious.)

These verses teach a principle that can apply to your efforts to prevail against the influences of the world:

**When we begin to follow the Lord's counsel, we receive strength to begin to prevail against the world.**

Read Doctrine and Covenants 103:8–10, looking for what the Lord warned would happen if the Saints chose not to obey His words.

What principle did the Lord teach in these verses regarding what will happen if we fail to keep His commandments? Complete the following “if–then” statement: **If we disobey the Lord’s commandments, then \_\_\_\_\_**

Read Doctrine and Covenants 103:9 again. How can you be “a light unto the world”? How can you be a “savior”?



**1.** Answer the following questions in your scripture study journal:

- What are some examples of how the Lord’s enemies try to prevail against members of the Church in our day?
- Why do you think someone who is not obedient or only partially obedient to the Lord might not be able to prevail against the enemies of the Lord?
- When have you seen someone gain victory over an enemy of the Lord by striving to obey the Lord’s words? (For example, you may think of someone who has overcome an addiction or who now lives the gospel after having lived a worldly lifestyle.)



**2.** Write one thing in your scripture study journal that you can start doing “from this very hour” (D&C 103:5) to better hearken to the Lord’s counsel. Write a plan of how you will do so.

Remember that while you might not be perfectly obedient to all of the Lord’s words, if you diligently strive to obey Him and if you sincerely repent and seek forgiveness through His Atonement when you fall short, He will help you prevail against His enemies.

In Doctrine and Covenants 103:11–21, we read the Lord’s promise that after the Saints’ tribulations, Zion would be redeemed by His power. But He also warned them that if the Saints polluted their inheritances, they would be removed from them. He spoke of the Prophet Joseph Smith as a man like Moses who would lead the people (see D&C 103:16, 21; see also D&C 28:2).

This comparison is true of every President of the Church (see D&C 107:91).

### Identifying Doctrines and Principles

One of the central purposes of the scriptures is to teach doctrines and principles of the gospel. As you study the scriptures, you can make these doctrines and principles clear in your mind by summarizing what you learn in brief, clear statements.

## Doctrine and Covenants 103:22–40

*The Lord reveals how the land of Zion is to be redeemed*

Read Doctrine and Covenants 103:22–23. These verses contain the Lord’s instructions for Church leaders at that time, in 1834. He commanded them to gather a group to go to the land of Zion, in Missouri, and help the Saints there. The group of men that Church leaders would gather together, to be led by the Prophet Joseph Smith, came to be known as Zion’s Camp (*camp* is another word for army). The members of Zion’s Camp had two main purposes. First, they were to take resources to the Saints in Missouri. With these resources, they would provide relief for the Saints and enable them to be restored to their homes. They would also use these resources to purchase additional land. Second, as authorized by Governor Daniel Dunklin of Missouri, after the Missouri state militia had escorted the Saints back to Jackson County, Zion’s Camp would be left to help maintain order and peace there.



Heber C. Kimball was one of the brethren who faithfully responded to the call to join Zion’s Camp. He later served as a member of the First Presidency. He told about his feelings as he left with Zion’s Camp: “We started on the 5th of

May, and truly this was a solemn morning to me. I took leave of my wife and children and friends, not expecting ever to see them again, as myself and brethren were threatened both in that country and in Missouri by the enemies, that they would destroy us and exterminate us from the land” (in “Extract from the Journal of Heber C. Kimball,” *Times and Seasons*, Jan. 15, 1845, 771; see also *Church History in the Fulness of Times Student Manual*, 2nd ed. [Church Educational System manual, 2003], 143).



**3.** Answer the following questions in your scripture study journal:

- If you had lived then, do you think you would have been willing to go to Jackson County to help the Saints? Why or why not?
- Joining Zion’s Camp required leaving family and work responsibilities to march about 900 miles (1,450 kilometers) through grueling conditions into a hostile and dangerous environment. Read Doctrine and Covenants 103:20. How might the promise in this verse affect your decision to volunteer?

Read Doctrine and Covenants 103:27–28, looking for what the Lord said to those who would join Zion’s Camp. You might consider marking the phrases that teach the following truth: **Disciples of Jesus Christ are willing to give their lives for His sake.**

For the Saints in Zion’s Camp, the possibility of losing their lives was real. While you might not face the same peril, this truth can still apply to you.



President James E. Faust of the First Presidency provided another way to think about giving our lives for the Lord’s sake: “For most of us, . . . what is required is not to *die* for the Church but to *live* for it. For many, living a Christlike life every day may be even more difficult than laying down one’s life” (“Discipleship,” *Ensign* or *Liahona*, Nov. 2006, 22).



**4. Complete the following activities:**

- a. Share the statement by President Faust with a family member or friend, and then ask the following question: *Why do you think it might be even more difficult to live for the Lord than to die for Him?*
- b. In your scripture study journal, record who you asked and write his or her response. Add your own insights about President Faust’s statement and the question.

Read Doctrine and Covenants 103:30–34, looking for how many volunteers the Lord desired for Zion’s Camp.

How many volunteers did the Lord desire?

---

What was the minimum number the Lord required?

---



**Zion’s Camp**

At the conclusion of the high council meeting in which Church leaders discussed the situation of the Missouri Saints, the Prophet Joseph Smith announced that he was going to Zion to help redeem it. Approximately 30 or 40 of the men present also volunteered. Then the Lord assigned 8 men to go throughout congregations of the Church to recruit volunteers for Zion’s Camp and to seek contributions of provisions and money for the Saints in Missouri (see D&C 103:37–40).

Read Doctrine and Covenants 103:35–36, and identify what the Saints needed to do in order to succeed in their efforts to redeem Zion. Consider marking the truth the Lord taught in verse 36 about how we can be victorious in accomplishing His work.

Reflect on how the devil seeks to hinder your spiritual progress. Is there a sin, temptation, or obstacle that is working against you in your efforts to follow the Lord? Look back at your response to activity 2 in your scripture study journal. How does your response relate to being diligent and faithful and praying in faith? Remember that, like the Saints in Joseph Smith’s day, you have the ability to gain victory over the enemies of the Lord and accomplish the Lord’s purposes as you pray in faith and as you diligently and faithfully obey His words.



**5. Write the following at the bottom of today’s assignments in your scripture study journal:**

*I have studied Doctrine and Covenants 103 and completed this lesson on (date).*

*Additional questions, thoughts, and insights I would like to share with my teacher:*

## UNIT 22: DAY 3

# Doctrine and Covenants 104

### Introduction

By the spring of 1834, the Church was having financial difficulties, and efforts to collect funds for its relief had failed. In 1832 the Lord directed Church leaders to “organize the Church’s mercantile and publishing endeavors by creating a ‘firm’ that would oversee these efforts, generating funds for the establishment of Zion and for the benefit of the poor. This firm, known as the United Firm, was organized in April 1832 and disbanded in 1834 (see section 82)” (Doctrine and Covenants 78 section introduction). On April 23, 1834, the Prophet Joseph Smith received the revelation recorded in Doctrine and Covenants 104. In this revelation the Lord revealed that the United Firm was to be reorganized and its properties were to be divided among its members as their stewardships. Under Joseph Smith’s direction, the term “United Firm” was later replaced with “United Order” in this

revelation. This lesson uses the term United Order to match the language of Doctrine and Covenants 104. The Lord also instructed Church members on how they were to care for the poor and counseled Church leaders regarding their debts. The members of the United Firm were Joseph Smith, Sidney Rigdon, Oliver Cowdery, William W. Phelps, Edward Partridge, John Whitmer, Sidney Gilbert, Martin Harris, Newel K. Whitney, John Johnson, and Frederick G. Williams.

## Doctrine and Covenants 104:1–18

### *The Lord gives instructions concerning the United Order*

Imagine that your parents have given you a key to their car (or think of something else that requires a key, such as your home). Does this make you the owner of the car? Can you use the car for whatever you want? Why or why not? How would knowing that you would be held accountable for what you do with it affect your use of the car?



In March and April 1832, the Lord directed leaders of the Church to organize the United Firm (or United Order), whose members would be responsible for overseeing the Church's mercantile and publishing operations in order to care for the poor and further His work. By the spring of 1834, Church leaders considered dissolving the firm for various reasons. The Lord, however, wanted the brethren to reorganize it and divide its properties among its members as their stewardships.

Read Doctrine and Covenants 104:1–4, and identify one of the reasons for the United Order's troubles.

Doctrine and Covenants 104:5–10 contains a decree from the Lord that the consequences for breaking the covenant associated with the United Order would include being cursed and being cut off from the Church.

Read Doctrine and Covenants 104:11–13, looking for what the Lord said each member of the United Order was to receive. (It might be helpful to know that a *steward* is a person who is given responsibility for something that belongs to someone else.)

Read Doctrine and Covenants 104:14, looking for who owned the property associated with the United Order.

Mark phrases that teach the doctrine that **the Lord created the earth, and all things in it are His**.



**1. Complete the following assignments in your scripture study journal:**

- Make a list of 10 earthly possessions that you have (for example, shelter, clothing, garden, food).
- Write about how the doctrine taught in Doctrine and Covenants 104:14 might influence the way you view and use your possessions.

The Lord's reminder to the Saints that all things upon the earth are His may have assured them that He could provide for their temporal needs. He continued by explaining how He would draw upon those resources to care for His Saints. Read Doctrine and Covenants 104:15–16, looking for how the Lord said He would provide for His Saints.



Elder Joseph B. Wirthlin of the Quorum of the Twelve Apostles provided insight into the Lord's way of providing for His Saints: "The Lord's way consists of helping people help themselves. The poor are exalted because they work for the temporary assistance they receive, they are taught correct principles, and they are able to lift themselves from poverty to self-reliance. The rich are made low because they humble themselves to give generously of their means to those in need" ("Inspired Church Welfare," *Ensign*, May 1999, 77). Today, "the Lord's way" of "helping people help themselves" includes the Church's welfare program and the gathering of fast offerings.

Read Doctrine and Covenants 104:17–18, looking for what the Lord instructed us to do with the abundance He has provided.

From these verses we learn that **we are accountable to use what the Lord has given us to help others**.

Think back to the example of the car key presented earlier in the lesson and how your use of the car would be influenced by your accountability for it. How does this relate to the truth you learned in Doctrine and Covenants 104:14–18?





We can think of “the poor and the needy” as not only those who are in need of financial assistance but also those in need of spiritual, emotional, mental, and social assistance. Likewise, we can think of our abundance as more than just the money or material possessions we have. Our abundance also includes our time, talents, knowledge, and skills.

 **2.** Answer the following questions in your scripture study journal:

- a. Why do you think it is important that we impart of the abundance we receive from the Lord?
- b. What are some examples in the scriptures of people who have helped those in need? How did they help others in the Lord’s way?
- c. How can you help others in the Lord’s way? (Write a specific goal to do so.)

### Doctrine and Covenants 104:19–77

*The Lord gives instructions concerning the United Order, stewardships, and the treasury*

In Doctrine and Covenants 104:19–53, the Lord gave specific instructions about the stewardships assigned to various members of the United Order.

Read Doctrine and Covenants 104:23, 25, 31, 33, 35, 38, 42, 46, looking for a pattern in the Lord’s promises to each member of the order. It may help you to know that the phrase “inasmuch as” means “insofar as” or “to the extent that.”

 **3.** Based on what you learned in these verses, write a principle in your scripture study journal explaining what will happen inasmuch as we are humble and faithful. Then answer the following questions:

- a. What can you learn from this principle about how obedience affects the blessings you receive?
- b. When have you seen someone be faithful in their responsibilities to the Lord and be blessed accordingly?

#### **Look for Connections, Patterns, and Themes**

When studying the scriptures, look for connections, patterns, and themes in various passages. Recognizing a pattern in instruction and promised blessings can help you consider how such instruction and blessings apply in your life.

In Doctrine and Covenants 104:54–77, the Lord provided instructions for establishing treasuries into which funds obtained from stewardships could be placed for the benefit of the Church, such as in printing the scriptures.

### Doctrine and Covenants 104:78–86

*The Lord instructs Church leaders regarding the United Order’s debts*

Think of a time when you were asked to do something that you thought was impossible or extremely difficult for you to accomplish.

In the process of obeying the Lord’s commands, the United Order had incurred a large debt. A number of events prevented the order from repaying the loans. For example, the mob’s destruction of the printing press in Jackson County, Missouri, kept the Saints from earning money from the printing of the scriptures and other products, and mobs also kept the Saints from using the storehouse in Independence.

Read Doctrine and Covenants 104:78, and mark the Lord’s instruction concerning the Church’s debts.

Repaying the debts may have felt impossible to the Saints, but the Lord gave instructions to help them.

 **4.** In your scripture study journal, make two columns—title one *IF* and the other *THEN*. Read Doctrine and Covenants 104:80–82. Under the “IF” column write what the Lord asked members of the order to do in order to receive His help in paying their debts. Under the “THEN” column write what the Lord promised to do to help the Saints get out of debt. Based on what you read and recorded, write a principle we can learn from these verses.

 **5.** Complete two or more of the following activities in your scripture study journal:

- a. Write about someone in the scriptures or someone you know who is an example of the principle you wrote in assignment 4. Describe how you see this principle in this person’s life. Or write about how you have seen this principle in your own life.
- b. Answer the following questions: What are some things the Lord has asked Church members to do that might be considered challenging? What role do you think humility, faithfulness, and prayer have in accomplishing the things the Lord has asked you to do?
- c. Write how you can be more humble, faithful, or prayerful so that the Lord can help you accomplish the things He has asked you to do. Write a goal to do so.

 **6.** Write the following at the bottom of today’s assignments in your scripture journal:

*I have studied Doctrine and Covenants 104 and completed this lesson on (date).*

*Additional questions, thoughts, and insights I would like to share with my teacher:*

## UNIT 22: DAY 4

# Doctrine and Covenants 105

### Introduction

In obedience to the Lord’s instructions, the Prophet Joseph Smith and about 200 other volunteers and recruits formed what became known as Zion’s Camp to go to the aid of the Saints who had been exiled from Jackson County, Missouri. On June 22, 1834, while encamped near Fishing River in Missouri, Joseph Smith received the revelation contained in Doctrine and Covenants 105. In this revelation the Lord provided instructions regarding the redemption of Zion.

## Doctrine and Covenants 105:1–19

*The Lord instructs the Saints to wait for the redemption of Zion*



Imagine being a member of an orchestra. In the middle of a performance, a few violin players decide to play from a different page of music than the rest of the orchestra. Just before they begin to do so, some flutists decide to play more quickly. At the same moment, the entire brass section decides to stop playing altogether.

As a member of this orchestra, how will you be affected by these decisions? What will be the result in the performance? Why is being unified in purpose and working together essential for an orchestra to produce beautiful music?

Remember that in February 1834, the Lord directed the Prophet Joseph Smith and others to gather temporal resources and recruit volunteers to assist the Saints who had been driven out of Jackson County, Missouri, in reclaiming their land. As you study Doctrine and Covenants 105, look for the role unity played in the Saints’ attempts to reclaim the land of Zion.

In a previous revelation (see D&C 103:30–34), the Lord stated His desire that 500 volunteers take part in Zion’s Camp. If 500 could not be obtained, 100 volunteers was the minimum He required. The response to the efforts of the Prophet Joseph Smith and others to recruit volunteers and resources for Zion’s Camp was not as successful as hoped for. By the time the camp began its march in the beginning of May 1834, only 122 people had volunteered to go. Zion’s Camp recruited additional volunteers along the way to Missouri. When the group that Hyrum Smith and Lyman Wight had recruited from Michigan Territory met up with Joseph’s company in early June 1834, Zion’s Camp consisted of just over 200 men, 12 women, and 9 children (see Alexander L. Baugh, “Joseph Smith and Zion’s Camp,” *Ensign*, Jun. 2005, 45).

The average age of the men in Zion's Camp was 29 years old. The youngest camp member was 14, and the oldest was 79. Joseph Smith, who had been selected to be "the commander-in-chief of the armies of Israel" (in *History of the Church*, 2:39), was only 28.

Read Doctrine and Covenants 105:7–8, looking for one reason why some members of the Church chose not to help their fellow Saints in Missouri.

Some Church members were waiting to see if God would intervene and help the Missouri Saints before they would aid or give financial support to their fellow Church members. What do you think is wrong with this attitude?

Read Doctrine and Covenants 105:1–6, looking for how disobedience and a lack of unity had affected members of the Church. It might be helpful to understand that "the law of the celestial kingdom" mentioned in verses 4–5 includes all of the laws and principles we need to obey, the ordinances we need to receive, and the covenants we need to keep to inherit the celestial kingdom.



**1.** Answer the following questions in your scripture study journal:

- a. What principle can we learn from these verses about what we must do in order for Zion to be built up?
- b. Why do you think unity and obedience are required to build up Zion?
- c. What experiences have helped you understand the importance of Church members being united?

Those who volunteered for Zion's Camp experienced many challenges and miracles throughout their expedition. Ponder how you might have responded to some of the following challenges:

Zion's Camp marched about 900 miles (1,450 kilometers) through four states, traveling between 20 and 40 miles (32 and 64 kilometers) a day for 45 days. Camp members experienced blistered feet, hot and humid weather conditions, food shortages, and unhealthy food. (See Alexander L. Baugh, "Joseph Smith and Zion's Camp," 44; *Church History in the Fulness of Times Student Manual*, 2nd ed. [Church Educational System manual, 2003], 143–44.) On occasion, intense thirst moved some camp members to drink swamp water from which mosquito larvae had been strained out (sometimes using their teeth) or to drink water out of horse tracks after a rainstorm. Throughout the expedition, Zion's Camp was also often threatened with violence from others. (See *Church History in the Fulness of Times*, 144–45.)

Despite their challenges, Zion's Camp was blessed to experience numerous miracles throughout their expedition. For example, on one hot day in June 1834, the camp had traveled all day and had been without water since morning. After observing the suffering of the men and their animals, the Prophet asked for a shovel, selected a spot, and dug a shallow well. Immediately, water filled it, and it remained full even after all of the camp members and their animals were refreshed.

In mid-June 1834, Zion's Camp was encamped on a fork of the Fishing River in Missouri. Five armed Missourians rode into camp and swore that the members of Zion's Camp would "see hell before morning" (in *History of the Church*, 2:103). They said that a mob of more than 300 men had combined from different counties and were preparing to cross the Missouri River to destroy them. Some of the men in Zion's Camp wanted to fight, but the Prophet promised that the Lord would protect them. The Prophet declared, "Stand still and see the salvation of God" (quoted from Joseph Holbrook, "History of Joseph Holbrook, 1806–1885," 15, in *Church History in the Fulness of Times*, 148.)



Fishing River, Missouri

A few minutes after the Missourians left, a small black cloud appeared in the sky. It moved eastward, unrolling like a scroll, filling the heavens with darkness. An intense storm of rain, hail, wind, thunder, and lightning struck. Zion's Camp abandoned their tents and found shelter in an old Baptist meetinghouse nearby. When Joseph Smith came in, he exclaimed, "Boys, there is some meaning to this. God is in this storm." The mobbers who attempted to cross the Missouri River were stopped by the storm. The furious storm soaked the mobbers' ammunition, making it useless. It also frightened and scattered their horses and raised the level of the Fishing River several



feet, preventing them from attacking Zion's Camp. (See *Church History in the Fulness of Times*, 148; see also *History of the Church*, 2:104–5.)

 **2.** These experiences illustrate significant and miraculous ways the Lord helped Zion's Camp. He also helped them in small ways. In your scripture study journal, write about a time when the Lord has helped you or someone you know accomplish His purposes.

Before Zion's Camp left Kirtland, Ohio, Church leaders had received a promise from Daniel Dunklin, the governor of Missouri, that if the Jackson County justices of the peace would not ensure the safety of the Saints, he would use other means to enforce the law. He also said that a state militia would be necessary to help the Saints return to their homes. After the members of Zion's Camp arrived in Missouri, they learned that Governor Dunklin would not keep his promise to assist the Saints. (See *Church History in the Fulness of Times*, 135, 146–47.) Despite this discouraging news, Zion's Camp continued on toward Jackson County, awaiting additional direction from the Lord.

This needed direction came in a revelation from the Lord on June 22, 1834, after Zion's Camp had been traveling for nearly seven weeks and was only 10–20 miles (16–32 kilometers) from Jackson County. This revelation is recorded in Doctrine and Covenants 105. Read Doctrine and Covenants 105:9–14, looking for what the Lord said they were to do regarding the redemption of Zion.



Imagine being a member of Zion's Camp. After having come this far, you learn that you are going to need to wait "a little season" before Zion will be redeemed. How would you feel?

 **3.** In your scripture study journal, list two of the reasons the Lord gave in Doctrine and Covenants 105:9–14 for why Zion would not be redeemed at that time. For each of these reasons, explain what would need to be corrected or take place before Zion could be redeemed and why.

Remember that redeeming Zion is not just about regaining possession of the land of Zion. Though Zion is a physical location, it is also a society composed of a certain type of people. The Lord's people must become sanctified and worthy to reclaim and build up the city of Zion.

Most members of Zion's Camp accepted the Lord's instructions in this revelation, but some murmured and did not continue faithful after they learned they would not fight in Missouri. They failed to understand that the deeper intent of Zion's Camp was not to engage in battle or regain possession of the Saints' land in Jackson County by military power. The men in the camp were prepared to fight should their lives be threatened, but the Lord does not intend to redeem Zion by the power of man (see D&C 103:15–18; 105:14). As a result of this revelation commanding them to wait and not fight, some men openly rebelled and later apostatized.

Read Doctrine and Covenants 105:18–19, looking for why the Lord brought Zion's Camp all the way to Missouri and then revealed once they arrived that they were not to act to restore the Saints to their lands in Zion at that time. (It might be helpful to understand that a trial of faith can refer to a test of whether or not we will choose to trust and obey the Lord no matter what the circumstances are.)

Consider marking phrases in verses 18–19 that teach the truth that **God has prepared blessings for those who are faithful through their trials.**

 **4.** Answer the following questions in your scripture study journal:

- a. When have you or someone you know experienced a trial of faith?
- b. How was the trial of faith preparation for future blessings?

One of the blessings many members of Zion's Camp received came as opportunities to serve in the Lord's kingdom. In February 1835, the Quorum of the Twelve Apostles and the First Quorum of the Seventy were organized. Nine of the original Apostles and all of the members of the Quorum of the Seventy served in Zion's Camp. (See *Church History in the Fulness of Times*, 151.)



The Prophet Joseph Smith taught about the role Zion's Camp had in preparing these men for their leadership positions: "God did not want you to fight. He could not organize His kingdom with twelve men to open the Gospel door to the nations of the earth, and with seventy men under their direction to follow in their tracks, unless He took them from a body of men who had offered their lives, and who had made as great a sacrifice as did Abraham" (in *History of the Church*, 2:182).

Church leaders later expressed gratitude for the experiences they had as members of Zion's Camp. For example, when Brigham Young returned to Kirtland, Ohio, a man asked him, "Well, what did you gain on this useless journey to Missouri with Joseph Smith?" Brigham Young replied, "All we went for." He added, "I would not exchange the *experience* I gained in that expedition for all the wealth of Geauga county" (in B. H. Roberts, "Brigham Young: A Character Sketch," *Improvement Era*, June 1903, 567). At the time, Kirtland was part of Geauga County.

### Doctrine and Covenants 105:20–41

*The Lord teaches the Saints what they are to do before Zion is redeemed*

In Doctrine and Covenants 105:20–37, we read that the Lord told the Saints in Missouri how they were to respond to the persecution they were experiencing while awaiting the future redemption of Zion. He counseled them to be humble and avoid stirring up contention. He explained that they needed to be sanctified in preparation for the eventual redemption of Zion. As He had said earlier in the same revelation, they were to "be taught more perfectly, and have experience, and know more perfectly concerning their duty, and the things which [He required] at their hands" (D&C 105:10).

The Lord concluded this revelation by instructing the Saints to do something not only for those who had persecuted them but for the entire world. Read Doctrine and Covenants 105:38–41, looking for what He instructed them to do. (As you read, it may be helpful to know that that *sue* means to seek for and an *ensign* is a banner or signal.)

 **5. Complete the following assignments in your scripture study journal:**

- Based on the Lord's teachings in Doctrine and Covenants 105:38–41, write a principle about the blessing that can come if we seek to establish peace with others.
- List four or five things that Church members in our day can do to seek to establish peace with others, especially with those who may persecute them.

**c. Select one of the things you listed, and write a goal to implement it in your life.**



**6. Write the following at the bottom of today's assignments in your scripture journal:**

*I have studied Doctrine and Covenants 105 and completed this lesson on (date).*

*Additional questions, thoughts, and insights I would like to share with my teacher:*

## UNIT 23: DAY 1

# Doctrine and Covenants 106; 107:1–20

### Introduction

The Prophet Joseph Smith received the revelation recorded in Doctrine and Covenants 106 on November 25, 1834. In this revelation the Lord called Warren Cowdery to preside over the Church in Freedom, New York, and the surrounding communities. The revelation in Doctrine and Covenants 107 was recorded in 1835, but the Lord gave certain parts of it to Joseph Smith at different times. At about the time the revelation was recorded, members of the recently organized Quorum of the Twelve Apostles were preparing to depart on missions. This is the first of three lessons on Doctrine and Covenants 107.

### Doctrine and Covenants 106

*The Lord calls Warren Cowdery as the presiding high priest in Freedom, New York*

Think of a time when a new bishop or branch president has been called. How do you think that person felt?

In 1834 the Church experienced significant growth in the community of Freedom, New York, a little less than 200 miles (approximately 322 kilometers) from Kirtland, Ohio. The Lord called a priesthood leader to preside over the members there. Read Doctrine and Covenants 106:1 to discover whom the Lord appointed to preside.



Warren Cowdery was Oliver Cowdery's older brother. When Warren Cowdery received the calling to serve as a presiding high priest, his feelings might have been similar to those of a new bishop or branch president today. The Lord shared comforting words as Brother Cowdery accepted his new calling. Read Doctrine and Covenants 106:2–3, looking for what the Lord asked Brother Cowdery to do as he presided over the Church members in the area of Freedom, New York.

Read Doctrine and Covenants 106:6, and find what Warren Cowdery had done that led to joy in heaven. As you read, note that a scepter is a staff carried by royalty. It is a symbol of authority. In this verse the phrase “bowed to my scepter” refers to Brother Cowdery humbling himself before God's power, and the phrase “separated himself from the crafts of men” likely refers to Brother Cowdery removing himself from vain and unrighteous activities.

Consider what you can do to humble yourself before God and separate yourself from unrighteous activities.

In Doctrine and Covenants 106:7–8, we read the Lord's counsel to Warren Cowdery and His promise to bless Warren for following that counsel. Read these verses, and summarize the Lord's promise by filling in the following blanks: **If we \_\_\_\_\_ ourselves**

**before the Lord, then He will have mercy on us,**  
 \_\_\_\_\_ **us up, and give us** \_\_\_\_\_



**1.** Answer the following questions in your scripture study journal:

- a. In what ways does the Lord lift up those who humble themselves before Him?
- b. When have you seen someone be lifted up because they were humble before the Lord?

## Doctrine and Covenants 107:1–20

### *The Lord teaches about the Melchizedek and Aaronic Priesthoods*

Try to guess which Old Testament prophet is described in the following paragraph:

This prophet “was a man of faith, who wrought righteousness; and when a child he feared God, and stopped the mouths of lions, and quenched the violence of fire” (Joseph Smith Translation, Genesis 14:26 [in the Bible appendix]). As king of Salem, he “did establish peace in the land in his days; therefore he was called the prince of peace” (Alma 13:18). The prophet Abraham paid tithes to him (see Alma 13:15).



Go to Alma 13:14–18 to identify who the prophet is. Then search Doctrine and Covenants 107:1–4 and find out why the Melchizedek Priesthood was named after the prophet Melchizedek.

What was the Melchizedek Priesthood called before Melchizedek’s day? \_\_\_\_\_

Consider marking the two reasons the members of the Church in ancient days called this priesthood after Melchizedek.

You may also consider marking the following doctrinal statement in Doctrine and Covenants 107:3: **The Melchizedek Priesthood is after the order of the Son of God.**



President Boyd K. Packer of the Quorum of the Twelve Apostles explained how this doctrine should be demonstrated in the lives of priesthood holders: “When priesthood authority is exercised properly, priesthood bearers do what He [Jesus Christ] would do if He were present” (“The Power of the Priesthood,” *Ensign* or *Liahona*, May 2010, 7).

You may want to write this explanation in your scriptures near Doctrine and Covenants 107:3.

 **2. In your scripture study journal, write about a time when you have seen someone exercise the priesthood properly by doing what Jesus Christ would do.**

Without the Melchizedek Priesthood, the Church would not exist. Search Doctrine and Covenants 107:5, 8–9, looking for words or phrases that teach

how the Melchizedek Priesthood relates to Church organizations such as Primary, Sunday School, Young Men, Young Women, and Relief Society. (Doctrine and Covenants 107:8 is a scripture mastery verse. You may want to mark it in a distinctive way so you can identify it easily.)

Notice in verse 5 that these organizations are called appendages. An appendage is a part of a body, such as an arm or a leg.

In order to understand the right and authority of the Melchizedek Priesthood, refer to Doctrine and Covenants 107:8 to complete the following statement:

**The Melchizedek Priesthood holds the right of \_\_\_\_\_, power and authority over \_\_\_\_\_, and the authority to administer in \_\_\_\_\_ things.**

“Administer[ing] in spiritual things” includes administering blessings, ordinances, and covenants.

 **3. In your scripture study journal, write about a time when you were blessed through the authority of the Melchizedek Priesthood. You might write about a time you received a blessing, participated in an ordinance, or made a covenant.**

The “Presidency of the High Priesthood,” mentioned in Doctrine and Covenants 107:9, is the First Presidency. Read Doctrine and Covenants 107:10, looking for who has the right to officiate under the direction of the First Presidency.

Stake presidencies and bishoprics are examples of high priests officiating in their own standing under the direction of the First Presidency.

Doctrine and Covenants 107:15–17 refers to the Presiding Bishop of the Church. Elder Bruce R. McConkie of the Quorum of the Twelve Apostles explained:



“This is the office which Aaron held anciently; the right to it is hereditary; it descends from worthy father to worthy son. . . . But in the absence of a revelation to the President of the Church, designating the lineage and

person to hold this high position of bishopric and Levitical presidency, the First Presidency chooses ‘a high priest of the Melchizedek Priesthood’ to hold the office. In this event two counselors are also called to serve in the Presiding Bishopric. (D. & C. 68:14–21; 107:15–17, 68–78.)

“As a holder of the keys of presidency over the Aaronic Priesthood of the Church and thus over all other bishops, the Presiding Bishop is one of the General

Authorities of the Church. He sits as a judge in Israel, is responsible for many of the temporal concerns of the kingdom (D. & C. 107:68–74), receives consecrations for the care of the Lord’s poor (D. & C. 42:31–33; 51:5, 12–13), and is called to travel and preach as an aid to building up the kingdom. (D. & C. 84:112–116)” (*Mormon Doctrine*, 2nd ed. [1966], 592).

Read Doctrine and Covenants 107:18, and mark the following doctrinal statement: **The Melchizedek Priesthood holds the keys of all the spiritual blessings of the Church.**

“Priesthood keys are the authority God has given to priesthood leaders to direct, control, and govern the use of His priesthood on earth. The exercise of priesthood authority is governed by those who hold its keys (see D&C 65:2; 81:2; 124:123). Those who hold priesthood keys have the right to preside over and direct the Church within a jurisdiction” (*Handbook 2: Administering the Church* [2010], 2.1.1). A jurisdiction is a geographic area where certain people have authority. For example, a bishop’s jurisdiction is his ward.

In Doctrine and Covenants 107:8–9, 18, we read about the power, authority, and order of the Melchizedek Priesthood. This right of presidency is associated with the keys of the priesthood. The term “keys of the priesthood” is used in at least three ways: keys bestowed upon the Apostles, keys of presidency, and a general use of “priesthood keys.”

**Keys bestowed upon the Apostles.** Those who are ordained Apostles are given (1) the apostolic keys, or the keys of the kingdom—the power and authority to preside over the Church and kingdom of God on the earth (see D&C 27:12–13); (2) the keys of the gathering of Israel, or missionary work (see D&C 110:11); (3) the keys of the dispensation of the gospel of Abraham and the restoration of all things (see D&C 110:12; see also D&C 27:6–7); and (4) the keys of the sealing power (see D&C 110:13–15). Only Apostles have these priesthood keys; they are not given to others.

“Jesus Christ holds all the keys of the priesthood pertaining to His Church. He has conferred upon each of His Apostles all the keys that pertain to the kingdom of God on earth. The senior living Apostle, the President of the Church, is the only person on earth authorized to exercise all priesthood keys (see D&C 43:1–4; 81:2; 107:64–67, 91–92; 132:7).

“Seventies act by assignment and by the delegation of authority from the First Presidency and Quorum of the Twelve Apostles. Area Presidents are assigned

to administer areas under the authorization of the First Presidency and the Twelve. The Presidency of the Seventy are set apart and are given the keys to preside over the Quorums of Seventy” (*Handbook 2*, 2.1.1).



**The keys of presidency.** “The President of the Church delegates priesthood keys to other priesthood leaders so they can preside in their areas of responsibility. Priesthood keys are bestowed on presidents of temples, missions, stakes, and districts; bishops; branch presidents; and quorum presidents. This presiding authority is valid only for the designated responsibilities and within the geographic jurisdiction of each leader’s calling” (*Handbook 2*, 2.1.1).

Upon receiving these priesthood keys, a priesthood leader has the authority to serve as a presiding officer. For example, a bishop serves as the presiding high priest in a ward and also as the president of the Aaronic Priesthood for the ward. Priesthood leaders who receive keys also are given the right to special gifts or power, such as discernment. For example, a



bishop serves as a common judge and receives the spiritual capacity to help members who need counsel with important personal problems, including serious transgressions.

“When priesthood leaders are released from their callings, they no longer hold the associated keys.

“Counselors to priesthood leaders do not receive keys. They are set apart and function in their callings by assignment and delegated authority.

“All ward and stake auxiliary organizations operate under the direction of the bishop or stake president, who holds the keys to preside. Auxiliary presidents and their counselors do not receive keys. They receive delegated authority to function in their callings” (*Handbook 2*, 2.1.1).

**General use of “priesthood keys.”** The general use of the term “priesthood keys” or “keys of the priesthood” can be understood as rights belonging to and available to priesthood leaders or, in many cases, to members in general. These rights must be defined in their respective contexts. For example, the keys of the ministering of angels are available to all Aaronic Priesthood holders by right (see D&C 13:1). The keys of the mysteries of the kingdom (see D&C 84:19–20; 128:14) are available in the temple. The keys of salvation are the doctrines and ordinances of the gospel and are provided to the seeker of truth and righteousness. Each of these keys must be qualified for and sought after for them to be manifest in the life of the individual.

In Doctrine and Covenants 107:19, we read about some of the blessings that come through the Melchizedek Priesthood. Read this verse, and identify those blessings.

The Prophet Joseph Smith explained the importance of the Melchizedek Priesthood in accessing blessings: “The Melchizedek Priesthood . . . is the channel through which all knowledge, doctrine, the plan of salvation, and every important matter is revealed from heaven” (in *History of the Church*, 4:207).

All members of the Church can receive the blessings associated with the Melchizedek Priesthood. These blessings are available to all who receive the ordinances of the temple and remain faithful to their covenants.

Think of someone you know who holds the Aaronic Priesthood. Read Doctrine and Covenants 107:13–14, 20, looking for what the Lord said about the authority of the Aaronic Priesthood.

Based on what you have learned from these verses, complete the following statement: **The Aaronic Priesthood holds the keys of \_\_\_\_\_ and administering in outward ordinances.**

What ordinance is mentioned in verse 20? What other ordinances are administered by the authority of the Aaronic Priesthood?

Elder Dallin H. Oaks of the Quorum of the Twelve Apostles explained the relationship between the ministering of angels and the ordinances of baptism and the sacrament:



“These ordinances of the Aaronic Priesthood are . . . vital to the ministering of angels.

“The word “angel” is used in the scriptures for any heavenly being bearing God’s message’ (George Q. Cannon, *Gospel Truth*, sel. Jerreld L. Newquist [1987], 54). The scriptures recite numerous instances where an angel appeared personally. . . . When I was young, I thought such personal appearances were the only meaning of the ministering of angels. As a young holder of the Aaronic Priesthood, I did not think I would see an angel, and I wondered what such appearances had to do with the Aaronic Priesthood.

“But the ministering of angels can also be unseen. Angelic messages can be delivered by a voice or merely by thoughts or feelings communicated to the mind. . . .

“. . . Most angelic communications are felt or heard rather than seen.

“In general, the blessings of spiritual companionship and communication are only available to those who are clean. . . . Through the Aaronic Priesthood ordinances of baptism and the sacrament, we are cleansed of our sins and promised that if we keep our covenants we will always have His Spirit to be with us. I believe that promise not only refers to the Holy Ghost but also to the ministering of angels, for ‘angels speak by the power of the Holy Ghost; wherefore, they speak the words of Christ’ (2 Ne. 32:3). So it is that those who hold the Aaronic Priesthood open the door for all Church members who worthily partake of the sacrament to enjoy the companionship of the Spirit of the Lord and the ministering of angels” (“The Aaronic Priesthood and the Sacrament,” *Ensign*, Nov. 1998, 38–39).



4. In your scripture study journal, write about how you have been blessed through the Aaronic Priesthood. (You may want to think about your baptism and your experiences partaking of the sacrament.)

Write each of the following priesthood offices under its correct heading in the following chart: elder, high priest, patriarch, Seventy, Apostle, deacon, teacher, priest, bishop. (Two priesthood offices, Apostle and bishop, have already been inserted in their correct places.)

Melchizedek Priesthood	Aaronic Priesthood
Apostle	Bishop

You will refer to this chart during the next two lessons as you learn more about priesthood offices.

### Scripture Mastery—Doctrine and Covenants 107:8



5. To become more familiar with Doctrine and Covenants 107:8, read the first word, “The,” aloud. Then read the first two words aloud: “The Melchizedek.” Continue this pattern until you have read the entire verse. Close your scriptures, and try to recite the entire verse from memory. If you cannot, open your scriptures again and repeat the process. In your scripture study journal, record when you completed this assignment.



6. Write the following at the bottom of today’s assignments in your scripture study journal:

*I have studied Doctrine and Covenants 106; 107:1–20 and completed this lesson on (date).*

*Additional questions, thoughts, and insights I would like to share with my teacher:*

## UNIT 23: DAY 2

# Doctrine and Covenants 107:21–38

### Introduction

In April 1835 the recently ordained members of the Quorum of the Twelve Apostles were in Kirtland, Ohio, preparing to depart on their first quorum mission. Before they left, the Prophet Joseph Smith shared with them some of the revelations he had received that are now contained in Doctrine and Covenants 107. This is the second of three lessons that cover this section. In this portion of the revelation, the Lord outlined the duties of the presiding quorums of the Church: the First Presidency, the Quorum of the Twelve Apostles, and the Seventy.

### Doctrine and Covenants 107:21–26

*The Lord outlines the duties and authority of the presiding quorums of the Church*

Think about a time when someone has supported, sustained, defended, or encouraged you. What difference did it make having someone help you in this way?

In the scriptures, to *uphold* someone means that we support, sustain, defend, or encourage that person. Read Doctrine and Covenants 107:21–22, looking for whom the Lord said Church members should uphold.

According to verse 22, how do we uphold the First Presidency? Answer the question by completing the following statement: **The First Presidency is upheld by the \_\_\_\_\_, \_\_\_\_\_, and \_\_\_\_\_ of the Church.** You may want to mark the words or phrases that teach this truth. (Note that in verse 22, the phrase “chosen by the body” does not mean that Church members select those who serve in the First Presidency. It refers to Church members’ willingness to sustain those leaders.)



1. Answer the following questions in your scripture study journal:

- a. What do you think it means to uphold the First Presidency by our confidence, faith, and prayers?
- b. From your experience, how are we blessed as we support and sustain the First Presidency?
- c. What do you learn from Doctrine and Covenants 107:21–22 about the First Presidency?

As you read the following statement from President Henry B. Eyring of the First Presidency, underline what he said we can do to sustain, or uphold, our Church leaders:



“For us to sustain those who have been called . . . , we must examine our lives, repent as necessary, pledge to keep the Lord’s commandments, and follow His servants. . . .

“. . . It would be wise to determine to sustain with our faith and our prayers all those who serve us in the kingdom. I am personally aware of the power of the faith of members of the Church to sustain those who have been called. . . . I have felt in powerful ways the prayers and the faith of people whom I do not know and who know me only as someone called to serve through the keys of the priesthood” (“The True and Living Church,” *Ensign* or *Liahona*, May 2008, 21).

Think about what you are currently doing to uphold the First Presidency and other Church leaders. In what ways can you better support, sustain, defend, or encourage them?

Read Doctrine and Covenants 107:23, looking for what the Lord said about the duties of the Twelve Apostles. What are the Twelve Apostles called to be?

You may want to mark the words or phrases in your scriptures that teach the following truth: **Apostles are special witnesses of the name of Jesus Christ in all the world.**

What do you think it means that the Apostles are special witnesses of the name of Jesus Christ?

Search in the Guide to the Scriptures or the Bible Dictionary for what it says about the word and title *Apostle*.

The President of the Church is the senior Apostle on the earth, and the counselors in the First Presidency are also Apostles. Therefore, members of the First Presidency are also special witnesses of the name of Jesus Christ.



Elder David A. Bednar of the Quorum of the Twelve Apostles taught what it means to be a special witness of the name of Christ: “The role of an Apostle today is the same as it was anciently (see Acts 1:22; 4:33). Our commission is to go into all the world and proclaim ‘Jesus Christ, and him crucified’ (see Mark 16:15; 1 Corinthians 2:2). An Apostle is a missionary and a special witness of the name of Christ. The ‘name of Christ’ refers to the totality of the Savior’s mission, death, and resurrection—His authority, His doctrine, and His unique qualifications as the Son of God to be our Redeemer and our Savior. As special witnesses of the name of Christ, we bear testimony of the reality, divinity, and resurrection of Jesus Christ, His infinite and eternal Atonement, and His gospel” (“Special Witnesses of the Name of Christ,” *The Religious Educator: Perspectives on the Restored Gospel*, vol. 12, no. 2 [2011], 1).



2. In your scripture study journal, write about how you have felt and what you have learned when you have listened to or read the witnesses, or testimonies, of the Apostles. (It may be helpful to review some past general conference talks of the Apostles in Church magazines.)

Read Doctrine and Covenants 107:24, looking for what the Lord said about the authority and power of the Quorum of the Twelve Apostles.

When men are ordained Apostles, they are given the same priesthood keys as the President of the Church. However, the President of the Church, as the presiding high priest over the Melchizedek Priesthood, is the only man on the earth who is authorized to exercise all of the keys of the priesthood. The other Apostles use these keys as authorized by the President of the Church. When a President of the Church dies, the First Presidency is dissolved and the Quorum of Twelve, which is equal in authority and power to the First Presidency, becomes the presiding body of the Church. As President of the Quorum of Twelve, the senior living Apostle is then authorized to exercise all of the keys of the priesthood.

Elder David B. Haight of the Quorum of the Twelve Apostles taught:



“When one Church President passes away, how is a new President selected?”

“In 1835 the Lord gave a revelation on this matter that provides for orderly succession. The revelation states that the Quorum of the Twelve Apostles is a body equal in authority to the First Presidency. (See D&C 107:24.) That means that when the President of the Church dies, the First Presidency is dissolved and the Quorum of the Twelve automatically becomes the presiding body of the Church. That pattern was established with the death of the Church’s first President, Joseph Smith. . . .

“This divinely revealed procedure for installing a new First Presidency of the Church—revelation from the Lord and sustaining by the people—has been followed to our present day. The First Presidency is to be ‘upheld by the confidence, faith, and prayer of the church.’ (D&C 107:22.)” (“A Prophet Chosen of the Lord,” *Ensign*, May 1986, 8).

In addition to explaining the duties of the First Presidency and the Quorum of the Twelve Apostles, the Lord also revealed the duties of the Seventy. Read Doctrine and Covenants 107:25, looking for what the Lord said about their duties.

You may want to mark the words or phrases in verse 25 that teach the following truth: **The Seventy are called to preach the gospel and to be witnesses of Jesus Christ in all the world.**

Read Doctrine and Covenants 107:26, looking for what the Lord said about the authority of the quorum of the Seventy.



Elder Earl C. Tingey of the Presidency of the Seventy taught about the authority of the Seventy: “The Seventy do not receive additional priesthood keys, but with each assignment they receive from the First Presidency or the Quorum of the Twelve Apostles, they are delegated authority to accomplish the assignment given” (“The Quorums of the Seventy,” *Ensign*, Aug. 2005, 48–49).

The following statements may help you understand the relationship between the First Presidency, the Quorum of the Twelve Apostles, and the Seventy:



“Jesus Christ holds all the keys of the priesthood pertaining to His Church. He has conferred upon each of His Apostles all the keys that pertain to the kingdom of God on earth. The senior living Apostle, the President of the Church, is the only person on earth authorized to exercise all priesthood keys. . . .



“Seventies act by assignment and by the delegation of authority from the First Presidency and Quorum of the Twelve Apostles. . . . The Presidency of the Seventy are set apart and are given the keys to preside over the Quorums of Seventy” (*Handbook 2: Administering the Church* [2010], 2.1.1).

Although the Lord said that the First Presidency, the Quorum of the Twelve Apostles, and the Seventy are “equal in authority” (D&C 107:24, 26), the First Presidency presides over the others. The Quorum of the First Presidency consists of the President of the Church and usually two counselors. The counselors are most often, but not always, selected from the Quorum of the Twelve Apostles. These “three Presiding High Priests . . . form a quorum of the Presidency of the Church” (D&C 107:22). Upon them rests the responsibility of directing the kingdom of God on the earth (see D&C 90:12–16). The Lord emphasized the significance of the First Presidency when He declared, “Whosoever receiveth me, receiveth those, the First Presidency, whom I have sent, whom I have made counselors for my name’s sake unto you” (D&C 112:20).

As explained earlier in this lesson, the Quorum of the Twelve Apostles becomes the presiding quorum in the Church only when a President of the Church dies. When a new President of the Church and his counselors are set apart, the First Presidency once again becomes the presiding quorum.

In speaking of the First Presidency, President Boyd K. Packer of the Quorum of the Twelve Apostles declared: “Thank God for the presidency. Like [three mountain] peaks, they stand with nothing above them but the heavens. They need our sustaining vote. It is sometimes lonely in those lofty callings of leadership—for their calling is not to please man, but to please the Lord. God bless these three great and good men” (“The Spirit Beareth Record,” *Ensign*, June 1971, 87).

### Doctrine and Covenants 107:27–32

*The Savior explains how the presiding quorums of the Church are to make decisions*

Think about a time when you had to make a decision as part of a group. What was your experience like?

How do groups of people generally make decisions? How do you think these decision-making processes compare to how the First Presidency, the Quorum of the Twelve Apostles, and the Seventy make decisions?

Read Doctrine and Covenants 107:27–32, looking for what the Lord taught about how the presiding quorums of the Church are to make decisions. You may want to mark phrases that help you understand how these quorums make decisions.

According to these verses, how are the decisions of the presiding quorums made?

You may want to write the following doctrinal statement in your scriptures near these verses: ***Decisions of the presiding quorums of the Church are made in unity and righteousness.***



3. Answer the following questions in your scripture study journal:

- How can knowing that the Lord promises to bless the First Presidency, the Quorum of the Twelve Apostles, and the Seventy with His knowledge help you uphold these leaders with confidence, faith, and prayer and follow their counsel?
- What are the qualities listed in Doctrine and Covenants 107:30 that are important for these Brethren to have in order to come to unified decisions?
- According to verse 31, what does the Lord promise the presiding quorums of the Church as they make decisions in unity and righteousness?

### Doctrine and Covenants 107:33–38

*The Lord gives additional direction to the presiding quorums of the Church*

Read Doctrine and Covenants 107:33–35, looking for the following truths:

- **The Twelve Apostles act in the name of the Lord and under the direction of the First Presidency in building up the Church.**
- **The Seventy act in the name of the Lord, under the direction of the Twelve Apostles.**
- **The Twelve Apostles hold the keys of proclaiming the gospel of Jesus Christ.**



4. In your scripture study journal, write some specific things you will do to uphold (support, sustain, defend, and encourage) the Lord’s chosen servants and better follow their counsel.



5. Write the following at the bottom of today’s assignments in your scripture study journal:

*I have studied Doctrine and Covenants 107:21–38 and completed this lesson on (date).*

*Additional questions, thoughts, and insights I would like to share with my teacher:*

# Doctrine and Covenants 107:39–100; 108

## Introduction

The first portion of this lesson covers Doctrine and Covenants 107:39–100. Although Doctrine and Covenants 107 was recorded in April 1835, most of the content in verses 60–100 was given to the Prophet Joseph Smith by revelation on November 11, 1831. The verses discussed in this lesson contain the Lord’s words about the ancient practice of conferring the Melchizedek Priesthood from father to son. They also provide instruction concerning the duties of various priesthood leaders. This lesson also covers Doctrine and Covenants 108, in which the Lord gave counsel and promises to Lyman Sherman.

## Doctrine and Covenants 107:39–100

*The Lord reveals that the Melchizedek Priesthood was passed down anciently from father to son*

 **1.** In your scripture study journal, write about some circumstances you currently face, or will soon face, in which you could benefit from receiving guidance or comfort from your Heavenly Father.

As you study Doctrine and Covenants 107:39–100, look for truths that can help you receive guidance and comfort from Heavenly Father.

In the previous lesson you learned some of the duties of the First Presidency, the Quorum of the Twelve Apostles, and the Seventy. Read Doctrine and Covenants 107:39, looking for one of the duties of the Quorum of the Twelve Apostles. The term “evangelical ministers” refers to those who hold the office of patriarch in the Melchizedek Priesthood (see Guide to the Scriptures, “Evangelist,” scriptures.lds.org; Bible Dictionary, “Evangelist”).

Complete the following based on what you have learned from verse 39: **Patriarchs are called by \_\_\_\_\_ and ordained under the direction of the Twelve Apostles.**



Those who hold the office of patriarch give special blessings, called patriarchal blessings, to worthy members of the Church. A patriarchal blessing contains the Lord’s counsel for an individual and declares that person’s lineage in the house of Israel (see *True to the Faith: A Gospel Reference* [2004], “Patriarchal Blessings,” 111–13).

As individuals study their patriarchal blessings, they can receive guidance and comfort from Heavenly Father. If you have not received a patriarchal blessing, consider talking with your parents and bishop or branch president about when would be the most appropriate time to receive one and what you need to do to prepare for the experience.

The word *patriarch* also refers to fathers. Doctrine and Covenants 107:41–57 teaches that Adam was a righteous father and patriarch. Scan verses 41–50, and identify a pattern—two things Adam did repeatedly as he presided over his family.

Read Doctrine and Covenants 107:53. In this verse we read that Adam blessed all his righteous posterity.



**2.** From what you learn in Doctrine and Covenants 107:41–57, answer the following questions in your scripture study journal:

- a. What two things did Adam do repeatedly as he presided over his family?
- b. How can Adam's example serve as a pattern for all fathers?

One truth we can learn from Doctrine and Covenants 107:53 is that **fathers who hold the Melchizedek Priesthood have authority to bless their children.** In addition to ordaining a son to the priesthood, a father might give a priesthood blessing to a son or daughter in times of illness or to provide direction and comfort.



In addition to blessing their children, Melchizedek Priesthood holders may give blessings to other family members and to others who ask for them. President Boyd K. Packer of the Quorum of the Twelve Apostles explained: "Homes without the priesthood are to be watched over and ministered to by the quorums of the priesthood. In this manner no blessings will be found wanting in any dwelling within the Church" ("The Power of the Priesthood," *Ensign* or *Liahona*, May 2010, 9).



**3.** In your scripture study journal, describe how you or people you know have benefited from receiving priesthood blessings from your father or other Melchizedek Priesthood holders. If you have not had the opportunity to receive a priesthood blessing, write about how you could benefit from seeking such a blessing.

Think back to the circumstances you wrote about for assignment 1 of this lesson. Remember that you can seek guidance and comfort from Heavenly Father through patriarchal blessings and through priesthood blessings administered by your father or other Melchizedek Priesthood holders.

In Doctrine and Covenants 107:58–98, we read about the duties of various priesthood leaders. As you study these verses, consider how those who fulfill these duties can bring the blessings of the priesthood into the lives of others.

Read Doctrine and Covenants 107:99–100, looking for the instructions the Lord gave to those who hold the priesthood.

President Thomas S. Monson taught: "The priesthood is not really so much a gift as it is a commission to serve, a privilege to lift, and an opportunity to bless the lives of others" ("Our Sacred Priesthood Trust," *Ensign* or *Liahona*, May 2006, 57).

## Doctrine and Covenants 108

### *The Lord gives counsel and blessings to Lyman Sherman*

Think of a time when you felt prompted by the Spirit to do something and you followed the prompting. What blessings did you receive when you obeyed the Spirit's promptings?

Lyman Sherman was a faithful member of the Church who had served in Zion's Camp and had been called as one of the seven Presidents of the Quorum of the Seventy. The Prophet Joseph Smith recorded in his journal that on December 26, 1835, "Brother Lyman Sherman came in, and requested to have the word of the Lord through me; 'for,' said he, 'I have been wrought upon to make known to you my feelings and desires, and was promised that I should have a revelation which should make known my duty'" (in *History of the Church*, 2:345).

When Lyman said he was "wrought upon" to talk to Joseph Smith, it means he was prompted by the Holy Ghost.

In response to Lyman's request, Joseph Smith received the revelation recorded in Doctrine and Covenants 108. Read Doctrine and Covenants 108:1, looking for the blessing the Lord gave Lyman because he obeyed the prompting to talk with the Prophet.

Based on what the Lord revealed to Lyman Sherman, complete the following principle: **As we \_\_\_\_\_ the Lord's voice, we invite His forgiveness.**



**4.** Answer the following question in your scripture study journal: Why do you think obeying promptings from the Lord invites forgiveness?

## Identifying Patterns

Patterns in the scriptures can guide our actions. Elder David A. Bednar of the Quorum of the Twelve Apostles taught, "A pattern is a plan, model, or standard that can be used as a guide for repetitively doing or making something. And the scriptures are full of spiritual patterns" ("A Reservoir of Living Water" [Church Educational System fireside for young adults, 2007], 4; si.lds.org). As you study the scriptures, look for patterns that can provide guidance for your life.



The Lord’s voice can be heard through the scriptures, the words of His prophets, and the promptings of the Holy Ghost. Obeying God includes filling your life with righteous activities that bring spiritual power. Full obedience brings the complete power of the gospel into your life. This obedience includes actions you might not initially consider part of repentance, such as attending Church meetings, paying tithing, giving service, and forgiving others. The Lord promised, “He that repents and does the commandments of the Lord shall be forgiven” (D&C 1:32).

Read Doctrine and Covenants 108:2, looking for the Lord’s counsel to Lyman Sherman after he was told his sins were forgiven.

What do you think it means to “let your soul be at rest concerning your spiritual standing” (D&C 108:2)?

We learn from Doctrine and Covenants 108:1–2 that **the Lord’s forgiveness brings rest to our souls.**

Sometimes repentant people wonder if they have been forgiven of their sins. In the following statements, mark the counsel given to those who may struggle to let their souls be at rest.

President Boyd K. Packer of the Quorum of the Twelve Apostles taught:



“That great morning of forgiveness may not come at once. Do not give up if at first you fail. Often the most difficult part of repentance is to forgive yourself. Discouragement is part of that test. Do not give up. That brilliant morning will come.

“Then ‘the peace of God, which passeth . . . understanding’ comes into your life once again. [Philippians 4:7.] Then you, like Him, will remember your sins no more. How will you know? You will

know! [See Mosiah 4:1–3.]” (“The Brilliant Morning of Forgiveness,” *Ensign*, Nov. 1995, 20).

President Harold B. Lee taught: “If the time comes when you have done all that you can to repent of your sins, whoever you are, wherever you are, and have made amends and restitution to the best of your ability . . . , then you will want that confirming answer as to whether or not the Lord has accepted of you. In your soul-searching, if you seek for and you find that peace of conscience, by that token you may know that the Lord has accepted of your repentance” (*Stand Ye in Holy Places* [1974], 185).

Study Doctrine and Covenants 108:3, looking for further counsel the Lord gave to Lyman Sherman. (It might be helpful to know that the word *observing* in this verse means to comply with or to obey. A *vow* is a promise or a covenant.)

In what ways is this counsel to be more careful in observing vows helpful for someone who has been forgiven of sin?



**5. In your scripture study journal, explain how the truths you have identified in Doctrine and Covenants 108:1–3 could encourage a friend or family member to obey the Lord’s voice and obtain forgiveness.**

Have you ever heard the term “solemn assembly”? Elder David B. Haight of the Quorum of the Twelve Apostles explained: “A solemn assembly, as the name implies, denotes a sacred, sober, and reverent occasion when the Saints assemble under the direction of the First Presidency. Solemn assemblies are used for three purposes: the dedication of temples, special instruction to priesthood leaders, and sustaining a new President of the Church” (“Solemn Assemblies,” *Ensign*, Nov. 1994, 14).

In December 1832, the Lord promised the Saints that if they would build a temple and hold a solemn assembly, He would bestow great blessings on them (see D&C 88:70–75, 117–19). In December 1835, when the revelation recorded in Doctrine and Covenants 108 was given to Lyman Sherman, the Kirtland Temple was only three months away from being dedicated.

As you read Doctrine and Covenants 108:4–6, look for what the Lord promised Lyman he would receive at the solemn assembly.

Next, read Doctrine and Covenants 108:7–8, looking for the instructions the Lord gave to Lyman. How can you strengthen others “in all your conversation” (D&C 108:7)? It may be helpful to know that *exhortations* are advice or encouragement to do good.



 **6.** Answer the following questions in your scripture study journal:

- a. How do you think the instructions in Doctrine and Covenants 108:7–8 could have helped Lyman Sherman as he preached the gospel to others?
- b. How can you apply the Lord’s counsel in verse 7 in your life?

 **7.** Write the following at the bottom of today’s assignments in your scripture study journal:

*I have studied Doctrine and Covenants 107:39–100; 108 and completed this lesson on (date).*

*Additional questions, thoughts, and insights I would like to share with my teacher:*

## UNIT 23: DAY 4

# Doctrine and Covenants 137

### Introduction

On January 21, 1836, the Prophet Joseph Smith met with his counselors in the First Presidency and his father, Joseph Smith Sr., in an upper room of the nearly completed Kirtland Temple. On this occasion the Prophet saw a vision of the celestial kingdom and heard the Lord declare how He will judge those who die without a knowledge of the gospel. Warren Parrish, Joseph Smith’s scribe at the time, recorded the vision in the Prophet’s journal. The record of the vision was later included in the Doctrine and Covenants as section 137.

### Doctrine and Covenants 137:1–6

*Joseph Smith receives a vision of the celestial kingdom*

Think about some of the most important people in your life. Why are they especially significant to you?

 **1.** In your scripture study journal, write why it is important to you to know that the people you love will have the opportunity to live in the celestial kingdom after they die.

Doctrine and Covenants 137 contains the Prophet Joseph Smith’s description of a vision in which he saw the celestial kingdom.

Read Doctrine and Covenants 137:1–4, looking for words and phrases that describe the celestial kingdom. Try to visualize what it would be like to be in the celestial kingdom.

Joseph Smith rejoiced to see some of his family members in the celestial kingdom. Read Doctrine and Covenants 137:3, 5–6, and identify whom Joseph Smith saw in the celestial kingdom.

Joseph’s parents were still alive at this time, and his father was even in the room with him during this vision. This indicates that this vision was not of those who were already in the celestial kingdom but of those who would eventually be there.

### Visualizing

As you study the scriptures, look for descriptive details that can help you create a mental picture. Imagining being present at certain events can help you better understand and relate to the events and people in the scriptures. This skill can also help strengthen your testimony of the reality of what you read in the scriptures.

 **2.** Answer the following questions in your scripture study journal:

- a. According to Doctrine and Covenants 137:6, why did Joseph Smith marvel (wonder) when he saw his brother Alvin in the celestial kingdom?
- b. What other feelings do you think Joseph may have had when he saw Alvin in the celestial kingdom?



Alvin Smith, the Prophet’s brother, died November 19, 1823, before the Church was organized.

The Prophet Joseph Smith loved and admired his oldest brother, Alvin. Alvin loved Joseph too, and he supported Joseph in his preparation to receive the gold plates from the angel Moroni. In November 1823, when Alvin was 25 years old and Joseph was 17, Alvin suddenly became gravely ill. As his condition worsened and it became apparent that he would soon die, he counseled Joseph: “I want you to be a good boy and do everything that lies in your power to obtain the records. Be faithful in receiving instruction and keeping every commandment that is given you” (quoted in *Teachings of Presidents of the Church: Joseph Smith* [2007], 401).

Alvin’s death brought great sorrow to the Smith family. “The family asked a Presbyterian minister in Palmyra, New York, to officiate at his funeral. As Alvin had not been a member of the minister’s congregation, the clergyman asserted in his sermon that Alvin could not be saved. William Smith, Joseph’s younger brother, recalled: ‘[The minister] . . . intimated very strongly that [Alvin] had gone to hell, for Alvin was not a church member, but he was a good boy and my father did not like it’” (*Teachings: Joseph Smith*, 401, 403).

### Doctrine and Covenants 137:7–10

*The Lord reveals how He will judge people who die without a knowledge of the gospel*

As the Prophet Joseph Smith was marveling how it was that Alvin was able to enter the celestial kingdom without being baptized, the Lord provided an answer. Study Doctrine and Covenants 137:7–8, and identify the doctrine that the Lord taught to help Joseph understand why Alvin would be able to enter the celestial kingdom.

 **3.** In your scripture study journal, record the doctrine you identified in Doctrine and Covenants 137:7–8, and answer the following question: How might this doctrine comfort those who have loved ones who have died without a knowledge of the gospel?

The Lord revealed the doctrine in Doctrine and Covenants 137:7–8 before He revealed the doctrine of baptism for the dead. You will study revelations on baptism for the dead in coming lessons.

As part of this revelation concerning those who have died, the Lord taught about how He will judge all people. Read Doctrine and Covenants 137:9, and complete the following statement: **The Lord will judge us by our \_\_\_\_\_ and the \_\_\_\_\_.**

 **4.** In your scripture study journal, explain in your own words why you think our desires and our works are both important.

To better understand how the Lord will judge us according to our works and our desires, study the following statement by Elder Dallin H. Oaks of the Quorum of the Twelve Apostles:



“Are we sure to be guiltless under the law of God if we merely refrain from evil acts? What if we entertain evil thoughts and desires?”

“Will hateful feelings go unnoticed in the day of judgment? Will envy? Will covetousness? . . .

“Our answers to such questions illustrate what we might call the bad news, that we can sin without overt [obvious] acts, merely by our feelings and the desires of our hearts.

“There is also good news. Under the law of God, we can be rewarded for righteousness even where we are unable to perform the acts that are usually associated with such blessings.

“When someone genuinely wanted to do something for my father-in-law but was prevented by circumstances, he would say: ‘Thank you. I will take the good will for the deed.’ Similarly, I believe that our Father in Heaven will receive the true desires of our hearts as a substitute for actions that are genuinely impossible” (“The Desires of Our Hearts” [Brigham Young University devotional, Oct. 8, 1985], 4; [speeches.byu.edu](http://speeches.byu.edu)).

 **5.** The following four examples can help you better understand the doctrine you identified in Doctrine and Covenants 137:7–8. In your scripture study journal, answer the following question for each of the examples: How does this example illustrate the importance of our desires as well as our works?

- a. A Church member has a righteous desire to be married in the temple. After a lifetime of faithful service in the Church, this member dies without having an opportunity to be sealed to a spouse in the temple.
- b. A young man valiantly keeps his baptismal covenants and performs his Aaronic Priesthood duties. After graduating from high school, he has a great desire to serve a full-time mission but is unable to do so because of a physical disability.
- c. A young woman holds a grudge against another young woman. She pretends to be friendly but secretly hopes that bad things will happen to the other young woman.
- d. A young man thinks lustful thoughts, and he does not seek the Lord’s help to change his inappropriate thoughts and feelings.

Ponder what it means to you to know you will be judged by your works and also by the desires of your heart.

Read Doctrine and Covenants 137:10, and mark the truth it teaches about children who die before the age of accountability.



When the Prophet Joseph Smith received this revelation in Doctrine and Covenants 137:10, he and his wife, Emma, had suffered the deaths of four of their children, including one adopted child. Later, two more of their children would also die. Think about how the doctrine revealed in this verse can bring comfort to families who grieve because of the death of a child.

How does this doctrine help increase your faith in God? Why do you think it is important to trust in God's plan when children die in their infancy?

Speaking about the death of little children, the Prophet Joseph Smith taught: "The Lord takes many away, even in infancy, that they may escape the envy of man, and the sorrows and evils of this present world; they were too pure, too lovely, to live on earth; therefore, if rightly considered, instead of mourning we have reason to rejoice as they are delivered from evil, and we shall soon have them again" (*Teachings of Joseph Smith*, 176).



President Wilford Woodruff taught: "The question may arise with me and with you—'Why has the Lord taken away my children?' But that is not for me to tell, because I do not know; it is in the hands of the Lord, and it has been so from the creation of the world all the way down. Children are taken away in their infancy, and they go to the spirit world. They come here and fulfil the object of their coming, that is, they tabernacle in the flesh. They come to receive a probation and an inheritance on the earth; they obtain a body, or tabernacle, and that tabernacle will be preserved for them, and in the morning of the

resurrection the spirits and bodies will be reunited, and as here we find children of various ages in a family, from the infant at the mother's breast to manhood, so will it be in the family organization in the celestial world. Our children will be restored to us as they are laid down if we, their parents, keep the faith and prove ourselves worthy to obtain eternal life; and if we do not so prove ourselves our children will still be preserved, and will inherit celestial glory. This is my view in regard to all infants who die" (*Teachings of Presidents of the Church: Wilford Woodruff* [2004], 84–85).



**6.** Answer the following questions in your scripture study journal:

- What have you learned from your study of Doctrine and Covenants 137 about the Lord's efforts to give all people the opportunity to live in the celestial kingdom?
- Why do these truths matter to you?



**7.** Write the following at the bottom of today's assignments in your scripture study journal:

*I have studied Doctrine and Covenants 137 and completed this lesson on (date).*

*Additional questions, thoughts, and insights I would like to share with my teacher:*

## UNIT 24: DAY 1

# Doctrine and Covenants 109





### Introduction

The Saints worked for nearly three years to complete the Kirtland Temple. When they were finished, the Lord revealed to the Prophet Joseph Smith the prayer that was to be offered at the temple's dedication. The Prophet read the prayer as part of the dedicatory services on March 27, 1836. He asked the Lord to accept the temple and to fulfill the promises He had made concerning it, including protection and blessings for those who would worship there. He prayed for the Saints who had been oppressed in Jackson County, Missouri, and he prayed for their oppressors as well. He also prayed that people throughout the world, especially scattered Israel, would be converted to the fulness of the gospel.

## Doctrine and Covenants 109:1–23

*Joseph Smith asks the Lord to accept the Kirtland Temple and bless those who worship there*

Do you know where each of these temples is located? Match the picture of each temple with its location. (Answers are found at the end of this lesson.)

<p>___ 1.</p> 	<p>a. Hong Kong, China</p>
<p>___ 2.</p> 	<p>b. Salt Lake City, Utah</p>
<p>___ 3.</p> 	<p>c. São Paulo, Brazil</p>
<p>___ 4.</p> 	<p>d. Kirtland, Ohio</p>
<p>___ 5.</p> 	<p>e. Tegucigalpa, Honduras</p>



1. Write the following question in your scripture study journal: *Why do Latter-day Saints build temples?* Write a few answers to this question. Leave room to add answers later in the lesson.

You can find answers to the question by studying Doctrine and Covenants 109, which contains the prayer that the Prophet Joseph Smith offered at the dedication of the temple in Kirtland, Ohio.

After almost three years of labor and sacrifice to build the Kirtland Temple, the Saints saw the fulfillment of the Lord’s promise that if they would keep His commandments, they would “have power to build it” (D&C 95:11). On March 27, 1836, Church members attended the dedicatory service for the temple, and the Prophet Joseph Smith offered the dedicatory prayer. Almost 1,000 people attended the dedicatory service. Many more wanted to attend, but they could not fit in the building. The Prophet arranged for them to participate in a meeting in another building, and the dedicatory service was repeated for them a few days later.

Have you ever participated in a temple dedicatory service? Imagine participating in the dedicatory service for the Kirtland Temple: This is the first temple to be built since ancient times. You have been looking forward to this day for a long time. There is an opening song by a choir. Next, Sidney Rigdon, a counselor in the First Presidency, delivers a sermon. After a brief break you have the opportunity to sustain Church leaders. Then the Prophet Joseph Smith stands and reads the dedicatory prayer.

Read Doctrine and Covenants 109:1–4, looking for the first reason the Saints built the temple. Note that today, as in the early days of the Church, **the Lord commands us to build temples.**

Read Doctrine and Covenants 109:5, looking for phrases that describe the Saints’ sacrifices to build the temple. You may want to mark what you find.





Between June 1833 and March 1836, Church members sacrificed time, money, and possessions to help build a house for the Lord. The men volunteered their labor on the construction. The women made clothing, provided lodging, and when many of the men were away with Zion's Camp to help with the troubles in Missouri, some women continued the work on the temple. Some Latter-day Saints, like John Tanner and Vienna Jacques, gave much of their wealth for the building of the temple.

As the construction progressed, the Saints realized they would need an alternative to brick for the exterior of the temple. It was suggested that a stonemason named Artemus Millet had the necessary skills to complete the exterior using a rubble-stone construction process. But Artemus lived in Canada and was not a member of the Church. Joseph Smith called Brigham Young to go to Canada to teach and baptize Artemus and bring him to Kirtland to help build the temple. Then the Prophet said, "And tell him to bring a thousand dollars with him" (quoted in M. Russell Ballard, "What Came from Kirtland" [Brigham Young University devotional, Nov. 6, 1994], 8–9; speeches.byu.edu). Brigham was obedient. Artemus chose to be baptized, and at great sacrifice he left his home in Canada to help build the temple.

Kirtland Temple Floor Plan

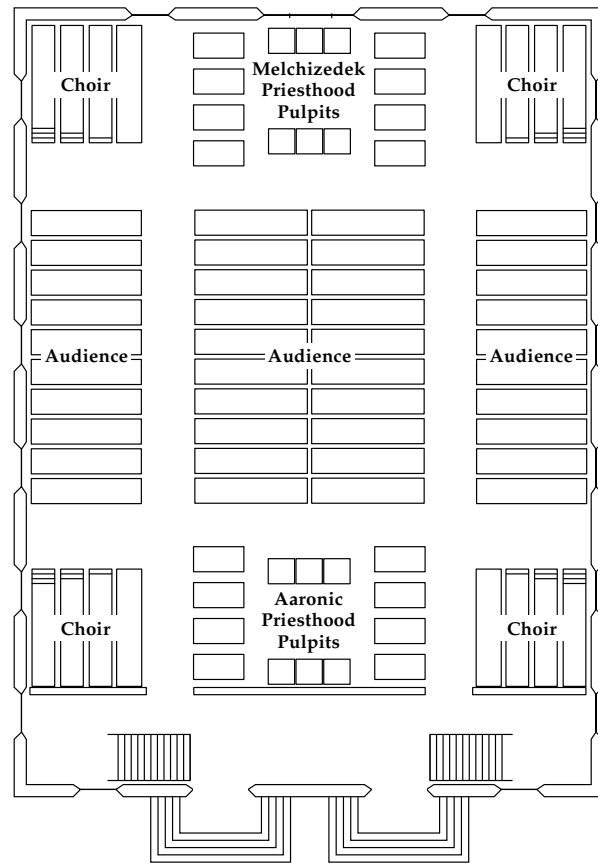

Floor plan of the lower level of the Kirtland Temple

The total cost of the temple was approximately \$60,000—an incredible sum for that time, especially considering the poverty of the Saints.



**2.** What impresses you about the sacrifices the Saints made to build the temple? Read Doctrine and Covenants 109:5 again, looking for a truth about the temple that explains why the Saints were willing to sacrifice so much to build it. Write that truth in your scripture study journal.

Think about what it means that the Lord will “manifest himself to his people” (D&C 109:5). The word *manifest* means to reveal or make known. To some people, this has included a physical appearance. To all who attend the temple worthily, He reveals Himself through the influence of the Holy Ghost and the doctrines that are taught there that help us know Him. The Lord can manifest Himself to His people outside of the temple also, but temples are places where those who are worthy can always feel His influence.

Read Doctrine and Covenants 109:12–13, looking for phrases that help you understand how the Lord can manifest Himself to you in the temple. Consider marking the phrases that are most meaningful to you.

 **3.** Write in your scripture study journal about times when you have felt close to the Lord in the temple. If you have not visited a temple, write about what you hope to feel when you have an opportunity to visit a temple.

Ponder how feeling close to the Lord in the temple can influence your life when you are outside the temple. Then study Doctrine and Covenants 109:14–23, looking for additional blessings promised to those who worship in the temple. You may want to mark what you find.

### Pondering

Pondering includes thinking, meditating, asking questions, and evaluating what you know and what you have learned. Pondering can help you understand what you need to do to apply gospel principles. Consider some of the blessings the Lord has promised those who worship and serve in the temple. Consider the lifestyle you must live so these promises will be fulfilled in your life.

One truth we can learn from Doctrine and Covenants 109:22–23 is that **receiving temple blessings arms us with power and with the Lord’s help as we serve Him**. In your scripture study journal, you may want to add this to your list of reasons why we build temples.

What do you think it means to be “armed with [God’s] power” (D&C 109:22)? Consider the following statement by Elder Joseph B.

Wirthlin of the Quorum of the Twelve Apostles, and identify the kind of power that can come to you as you worship in the temple: “In the house of the Lord, faithful Church members can be endowed ‘with power from on high,’ [D&C 95:8] power that will enable us to resist temptation, honor covenants, obey the Lord’s commandments, and bear fervent, fearless testimony of the gospel to family, friends, and neighbors” (“Cultivating Divine Attributes,” *Ensign*, Nov. 1998, 27).

 **4.** Answer the following questions in your scripture study journal:

- How would this kind of power be a blessing to you and your family?
- How would it be a blessing for missionaries?

## Doctrine and Covenants 109:24–34

*The Prophet prays that the Lord will protect and bless the people who worship in the temple*

Look at the accompanying pictures of a trowel and a sword. A trowel is a tool used to apply mortar between bricks or stones. How might each of these tools be used in building a temple?

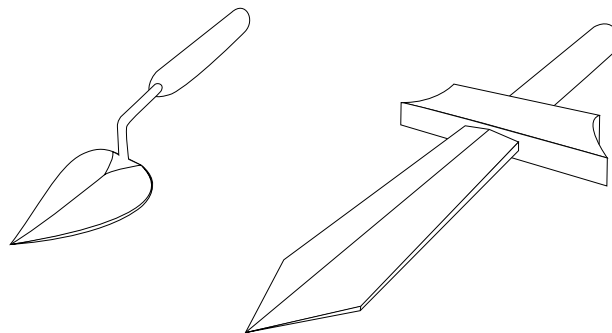

During the construction of the Kirtland Temple, mobs threatened to destroy the temple walls. President Brigham Young told of “laborers on the walls, holding the sword in one hand to protect themselves from the mob, while they placed the stone and moved the trowel with the other” (*Discourses of Brigham Young*, sel. John A. Widtsoe [1954], 415). At times, the men who worked on the temple during the day also had to guard it at night.

Read Doctrine and Covenants 109:24–28, looking for the kind of protection the Prophet Joseph Smith requested of the Lord.

In verse 24, notice the phrase “honorably hold a name and standing.” This refers to the need to be worthy to worship the Lord in the temple and to be true to the covenants we make there.

From what you read in Doctrine and Covenants 109:24–28, complete the following principle: **If we are worthy and worship the Lord in the temple, then**

(You will probably find many ways to complete this statement. For example, you might see that one blessing of worshipping in the temple is that “no weapon formed against [us] shall prosper” [D&C 109:25]. You may want to add this principle and others to your list of reasons why we build temples.)

In Doctrine and Covenants 109:29–34, we read how the Prophet Joseph Smith prayed that those who spread lies about the Saints would be confounded and that Church members would be able to rise up and do the Lord’s work.

## Doctrine and Covenants 109:35–67

*Joseph Smith prays for the leaders of the Church, for the Saints in Missouri, for the Saints' oppressors, and that the nations of the earth will listen to the missionaries*

The Saints were looking forward to the endowment of power and glory that was promised to them as a result of building the Kirtland Temple. In Doctrine and Covenants 109:35–46, the Prophet Joseph Smith pled with the Lord to fill the temple with His glory and to provide His servants with the testimony and power they would need to proclaim the gospel.



On the evening of March 27, 1836, after the temple dedication, priesthood quorums met in the temple. Joseph Smith said that he “gave them instructions in relation to the spirit of prophecy, and called upon the congregation to speak. . . .

“Brother George A. Smith arose and began to prophesy, when a noise was heard like the sound of a rushing mighty wind, which filled the Temple, and all the congregation simultaneously arose, being moved upon by an invisible power; many began to speak in tongues

and prophesy; others saw glorious visions; and I beheld the Temple was filled with angels, which fact I declared to the congregation. The people of the neighborhood came running together (hearing an unusual sound within, and seeing a bright light like a pillar of fire resting upon the Temple), and were astonished at what was taking place” (in *History of the Church*, 2:428). The New Testament tells of a similar event among faithful Saints who gathered shortly after the Resurrection of Jesus Christ. That event, which is often called the day of Pentecost, is recorded in Acts 2. You may want to cross-reference Doctrine and Covenants 109:36–37 with Acts 2:2–3.

In Doctrine and Covenants 109:47–67, we read that Joseph Smith prayed for the Saints who had been driven from their homes in Missouri and that he prayed for those who had oppressed them. He also prayed for the Lord to soften the hearts of the people of the earth so they would receive the servants who would go forth from the temple to preach the gospel.

## Doctrine and Covenants 109:68–80

*The Prophet prays for the Church and that the Lord will accept the dedication of the temple*

Search Doctrine and Covenants 109:68–69, 71–73, 78–80, looking for additional requests the Prophet made in the dedicatory prayer.

 **5.** In your scripture study journal, list some of the requests the Prophet made in these verses. Then write what benefits you think could come from including such requests in your prayers.

If you have a Church hymnbook, turn to “The Spirit of God” (*Hymns*, no. 2). This hymn was sung at the Kirtland Temple dedication, immediately after the dedicatory prayer (see the note below the hymn). This hymn continues to be sung at temple dedications today. Listen to, read, or sing the hymn.

 **6.** Write the following at the bottom of today's assignments in your scripture study journal:

*I have studied Doctrine and Covenants 109 and completed this lesson on (date).*

*Additional questions, thoughts, and insights I would like to share with my teacher:*

Answers for the matching activity: (1) b, (2) a, (3) e, (4) c, (5) d.



# Doctrine and Covenants 110

## Introduction

On Sunday, April 3, 1836, a sacrament meeting was held in the Kirtland Temple. During the meeting the Prophet Joseph Smith and Oliver Cowdery separated themselves from the congregation to pray. After they rose from prayer, Jesus Christ appeared to them and accepted the newly dedicated temple. Moses, Elias, and Elijah then appeared, and priesthood keys were restored. Doctrine and Covenants 110 is an account of these visions.

## Doctrine and Covenants 110:1–10

*The Lord appears and accepts the Kirtland Temple*

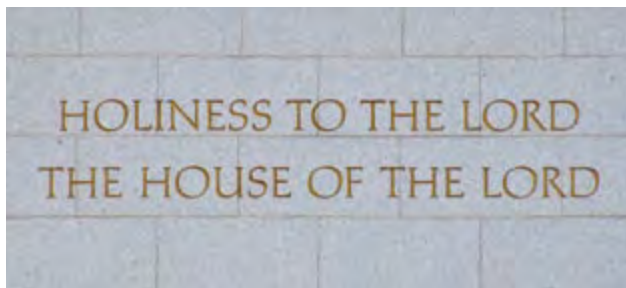

Have you ever noticed the phrase written on the outside of every temple? It reads “Holiness to the Lord—the House of the Lord.”

Because a temple is the house of the Lord, can you think of a time when the Lord visited one?

One visit was shortly after the dedication of the Kirtland Temple. Read the section introduction to Doctrine and Covenants 110, looking for who was present and what they did before this sacred experience.

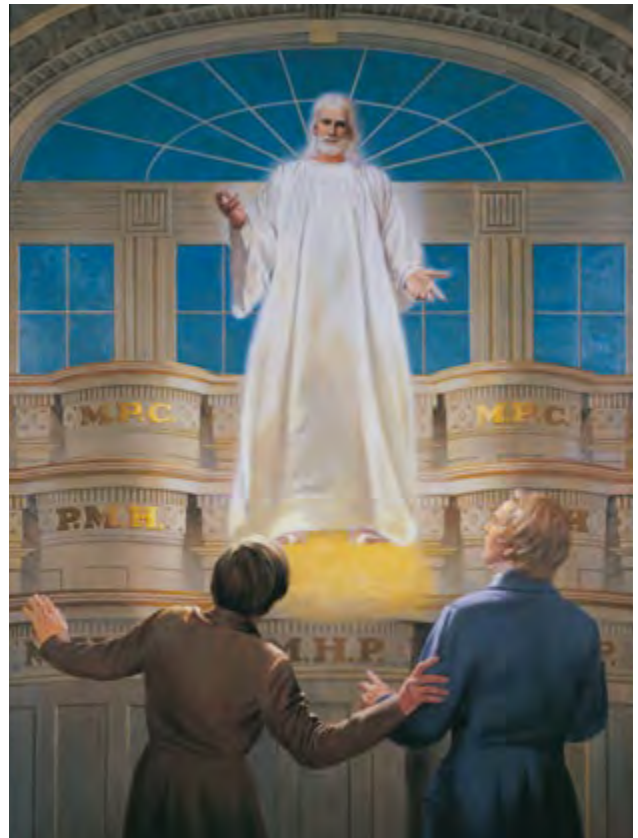

Read the Prophet Joseph Smith’s account of the vision in Doctrine and Covenants 110:1–3. Try to visualize what happened, and imagine how you might have felt if you were there. Then read Doctrine and Covenants 110:4–5, and find what the Savior said to Joseph Smith and Oliver Cowdery. You may want to mark phrases that are meaningful to you.

 **1.** In your scripture study journal, write about what you find meaningful in Doctrine and Covenants 110:4–5, and explain why.

Doctrine and Covenants 110:5 contains the Lord’s instructions for Joseph and Oliver to lift up their heads and rejoice. Read Doctrine and Covenants 110:6–10, and identify reasons that Joseph and Oliver, as well as the Saints, had to rejoice. Consider marking what you find.

One of the reasons the Saints had to rejoice is found in verses 7–8. These verses teach the following principle: **If we obey the Lord’s commandments and keep His house pure, He will manifest Himself to us in His temples.**





2. If you have had the opportunity to visit or go inside a temple, write in your scripture study journal about when you felt close to the Lord there. If you have not had the opportunity, write about feelings you might have there. Then answer the following questions:

- a. How can the Lord manifest Himself to people in the temple? (The word *manifest* means to reveal or make known, as discussed during your study of Doctrine and Covenants 109.)
- b. How can we keep the Lord's house pure and unpolluted?
- c. Why do you think the Lord requires us to be obedient and clean before He will manifest Himself to us in His house?

Review Doctrine and Covenants 110:9–10, and identify who will be blessed by the restoration of temple blessings.



3. In your scripture study journal, answer the following questions:

- a. How is the world blessed by temples and the work of salvation for both the living and the dead?
- b. How has the temple blessed your life?

### Doctrine and Covenants 110:11–16

*Moses, Elias, and Elijah appear, and priesthood keys are restored to Joseph Smith and Oliver Cowdery*

Look in Doctrine and Covenants 110:11–13 for who appeared individually to the Prophet Joseph Smith and Oliver Cowdery after the vision of the Savior. You may want to mark these names.



Moses



Elijah

Do you know who Moses and Elijah are and some of the significant things they did when they were on the earth? To learn more about these two Old Testament prophets, look up their names in the Bible Dictionary or the Guide to the Scriptures.

Elias may have been a prophet who lived in Abraham's day. In addition to a name, *Elias* is a title meaning forerunner or restorer. (See Guide to the Scriptures, "Elias," scriptures.lds.org; Bible Dictionary, "Elias.")

Each of the three messengers who appeared in the Kirtland Temple committed priesthood keys to Joseph Smith and Oliver Cowdery.



4. Copy the following chart into your scripture study journal. Then study the scripture passage written under each prophet's name and write what each one restored.

<i>Moses</i> (D&C 110:11)	<i>Elias</i> (D&C 110:12)	<i>Elijah</i> (D&C 110:13–16)

The following information can help you understand the keys or authority you identified in Doctrine and Covenants 110:11–16.

### "The keys of the gathering of Israel"

The Lord gave the name Israel to Jacob, who was the son of Isaac and the grandson of Abraham (see Genesis 32:28). Jacob's descendants, who came to be known as the kingdom of Israel, were God's covenant people. Over

time, the people of Israel and their descendants have been scattered throughout the earth, largely because of their unrighteousness. The Lord has promised to gather His covenant people (see 1 Nephi 15:13–14; 3 Nephi 5:24; 16:5; 29:1, 3). Descendants of Jacob and all other people are gathered to the Lord’s kingdom through missionary work. The priesthood keys Moses restored expanded missionary labors in the Church to the whole earth.

Elder Russell M. Nelson of the Quorum of the Twelve Apostles explained: “Missionary work is crucial to the gathering of Israel. . . . In many nations our missionaries have searched for those of scattered Israel” (“The Gathering of Scattered Israel,” *Ensign or Liahona*, Nov. 2006, 81).



President Spencer W. Kimball taught: “The gathering of Israel consists of joining the true church and their coming to a knowledge of the true God. . . . Any person, therefore, who has accepted the restored gospel, and who now seeks to worship the Lord in his own tongue and with the Saints in the nations where he lives, has complied with the law of the gathering of Israel and is heir to all of the blessings promised the Saints in these last days” (*The Teachings of Spencer W. Kimball*, ed. Edward L. Kimball [1982], 439).

You might want to write *missionary work* on the chart, in the column under the heading “Moses.”

## “The dispensation of the gospel of Abraham”



The dispensation of the gospel of Abraham, committed to the Prophet Joseph Smith and Oliver Cowdery by Elias, restored the promises the Lord made to Abraham. Elder Bruce R. McConkie of the Quorum of the Twelve Apostles explained: “Elias brings back ‘the gospel of Abraham,’ the great Abrahamic covenant whereby the faithful receive promises of eternal increase, promises that through celestial marriage their eternal posterity shall be as numerous as the sands upon the seashore or as the stars in heaven for multitude. Elias gives the promise—received of old by Abraham, Isaac, and Jacob—that in modern men and in their seed all generations shall be blessed. And we are now offering the blessings of Abraham, Isaac, and Jacob to all who will receive them” (“The Keys of the Kingdom,” *Ensign*, May 1983, 22).

You might want to write *celestial marriage and eternal posterity* on the chart, in the column under the heading “Elias.”

## “The keys of this dispensation”

To help you understand the priesthood keys Elijah restored, read the following statements:



President Joseph Fielding Smith taught: “This sealing power bestowed upon Elijah, is the power which binds husbands and wives, and children to parents for time and eternity. It is the binding power existing in every Gospel ordinance. . . . It is by this power that all the ordinances pertaining to salvation are bound, or sealed, and it was the mission of Elijah to come, and restore it” (*Elijah the Prophet and His Mission* [1957], 5).

Elder David A. Bednar of the Quorum of the Twelve Apostles explained:

“As members of Christ’s restored Church, we have the covenant responsibility to search out our ancestors and provide for them the saving ordinances of the gospel. ‘They without us should not be made perfect’ (Hebrews 11:40 . . .). And ‘neither can we without our dead be made perfect’ (D&C 128:15).

“For these reasons we do family history research, build temples, and perform vicarious ordinances. For these reasons Elijah was sent to restore the sealing authority that binds on earth and in heaven” (“The Hearts of the Children Shall Turn,” *Ensign or Liahona*, Nov. 2011, 25–26).

According to these explanations, what power or authority did Elijah restore? (You may want to write your answer on your chart in the column under the heading “Elijah.”)



When Elijah came to the Kirtland Temple, he fulfilled Malachi's prophecy that Elijah would come "before the coming of the great and dreadful day of the Lord" to "turn the heart of the fathers to the children, and the heart of the children to their fathers" (Malachi 4:5–6).

 **5.** In your scripture study journal, write about how your life has been affected by the restoration of at least one of these priesthood keys (missionary work, celestial marriage and eternal posterity, or the sealing power, including temple and family history work).

President Joseph Fielding Smith noted that the Kirtland Temple "was built primarily for the restoration of keys of authority. In the receiving of these keys the fulness of gospel ordinances [was] revealed" (*Doctrines of Salvation*, comp. Bruce R. McConkie, 3 vols. [1954–56], 2:242). These keys rest today with the President of the Church and the Quorum of the Twelve Apostles.

Complete the following statement: From Doctrine and Covenants 110:11–16, we learn that **the keys of missionary work, eternal families, and temple work help us prepare for** \_\_\_\_\_.

You live in a day when you can do missionary work, family history work, and temple work and when you can look forward to receiving the blessings of the temple, including the sealing ordinance. Consider making a goal to participate in these efforts in preparation for the Lord's Second Coming. You could also set a specific goal of how you will prepare for a celestial marriage. Ask Heavenly Father to help you fulfill your goal.

 **6.** Write the following at the bottom of today's assignments in your scripture study journal:

*I have studied Doctrine and Covenants 110 and completed this lesson on (date).*

*Additional questions, thoughts, and insights I would like to share with my teacher:*

## UNIT 24: DAY 3

# Doctrine and Covenants 111

## Introduction

In 1836 the Church was deeply in debt. The Prophet Joseph Smith and other Church leaders traveled to Salem, Massachusetts, where they hoped to be able to obtain money to pay the Church's debts. On August 6, 1836, Joseph Smith received the revelation recorded in Doctrine and Covenants 111, in which the Lord reassured him about concerns regarding debt and the welfare of Zion. The Lord also gave the Prophet instructions related to the Church leaders' stay in Salem.

## Doctrine and Covenants 111

*The Lord provides reassurance and instruction for Joseph Smith and other Church leaders*

 **1.** In your scripture study journal, list some of the things that bring stress or anxiety into your life.

Ponder the stressful situation the Prophet Joseph Smith and other Church leaders were facing as you read the following information:

In the summer of 1836, the Prophet Joseph Smith and other Church leaders were concerned about the Church's finances. In the preceding years, the Church had incurred a large amount of debt as Church leaders had obeyed the Lord's commands to build the Kirtland Temple, purchase lands in Ohio and Missouri, and fund Zion's Camp. The Church also needed funds to buy land for the Saints in Missouri who had been forced from their homes. In 1834 the Lord had instructed Joseph Smith and other Church leaders to "pay all [their] debts" (D&C 104:78). However, their efforts to pay these debts had been hampered by the loss of income-producing businesses in Missouri. Thus, Church leaders did not have sufficient funds to meet the demands of the Church's creditors.



If you had been a Church leader at this time, why might this situation have concerned you?

The Lord had told Church leaders that He would “send means unto [them] for [their] deliverance” (D&C 104:80) from the Church’s debt problems. In 1836 a member of the Church named William Burgess arrived in Kirtland, Ohio, and told Church leaders about a large amount of money available in Salem, Massachusetts. He said the money was located in the cellar of a house and that he was the only living person who knew about the location of the money.

If you had been a Church leader at this time, how might you have responded to this news?

Joseph Smith, Sidney Rigdon, Hyrum Smith, and Oliver Cowdery left Kirtland, Ohio, on July 25, 1836, to meet with the Church’s creditors in New York. After a few days in New York, the group traveled to Salem, Massachusetts. William Burgess met them in Salem, but he stated that the city had changed so much since he had last been there that he was unable to locate the house that contained the money. Brother Burgess left Salem shortly thereafter.

How do you think you would have felt after traveling to Salem in hopes of finding the means to help pay the Church’s debt and not finding what you expected? What would you have done?

The Church leaders spent some time looking for the house that reportedly contained the money. On August 6, 1836, while they were still in Salem, the Prophet Joseph Smith received the revelation recorded in Doctrine and Covenants 111.

Read Doctrine and Covenants 111:1, looking for how the Lord felt about the journey to Salem. The word *folly* may be defined as “a weak or absurd act not highly criminal; an act which is inconsistent with the dictates of reason, or with ordinary rules of prudence” (*Noah Webster’s First Edition of an American Dictionary of the English Language, 1828 [1967], “folly”*). Sometimes when people engage in follies, they are sincerely trying to do something good even though their actions are misguided.

Although the search for money in Salem had been unsuccessful, the Lord indicated that this journey could still benefit His kingdom. Read Doctrine and Covenants 111:2, and identify what the Lord said He had in the city of Salem.

Notice in verse 2 that the Lord said He would gather out the people He had in Salem in due time. Joseph Smith and those with him spent a few weeks in Salem, and they preached the gospel during their stay. Five years later, Erastus Snow was called on a mission to Salem, where he organized a branch of 120 members (see *Church History in the Fulness of Times Student Manual*, 2nd ed. [Church Educational System manual, 2003], 170–71).

One truth we can learn from Joseph Smith’s experience in Salem and the Lord’s teachings in Doctrine and Covenants 111:1–2 is that **the Lord can bring forth good from our sincere efforts.**





2. Answer the following questions in your scripture study journal:

- In what ways can the Lord bring forth good from our efforts, even if those efforts are originally misguided?
- How does it influence you to know that the Lord can bring forth good from your sincere efforts?

The Lord gave instructions to Joseph Smith and his companions to help them accomplish good while they were in Salem, Massachusetts. Search Doctrine and Covenants 111:3–8, looking for what the Lord wanted them to do. (In verse 4, the phrase “they shall not discover your secret parts” means that the people of Salem would not look upon these Church leaders with shame.)

The Lord taught Joseph Smith and the other Church leaders in Salem how they would know where to stay in that city. Use the Lord’s words in verse 8 to complete the following doctrinal truth: **We can receive the Lord’s direction through the \_\_\_\_\_ and \_\_\_\_\_ of His Spirit.**



3. In your scripture study journal, write about how remembering this doctrine can help you with the concerns and challenges you face in your life.

Read Doctrine and Covenants 111:9–10, looking for an additional task the Lord gave Joseph Smith and his companions to complete while they were in Salem.

The Prophet Joseph Smith and the other men followed the Lord’s counsel to “inquire diligently concerning the more ancient inhabitants and founders of [the] city” (D&C 111:9). They visited historical sites while they were in Salem. From these visits they learned that some residents of Salem, Massachusetts, and the surrounding New England area had been persecuted and killed as a result of religious intolerance and bigotry. (See *History of the Church*, 2:464–65.) These events led Joseph Smith to write in his history, “When will man cease to war with man, and wrest [take] from him his sacred rights of worshiping his God according as his conscience dictates?” (in *History of the Church*, 2:465).

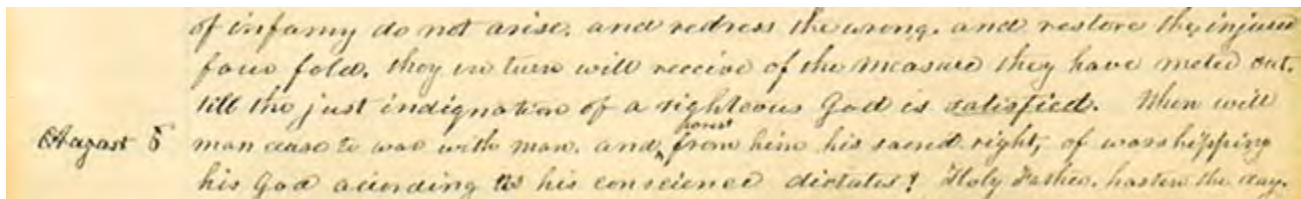

Entry from Joseph Smith’s history

The Prophet later stated that it was one of the fundamental beliefs of the Church to allow all people the right of religious freedom (see Articles of Faith 1:11).

Although Joseph Smith and his companions did not obtain the money they thought they might find in Salem, they obtained other treasures from this journey. These included treasures of knowledge and of people in the area who were later baptized and confirmed members of the Church.

Read Doctrine and Covenants 111:11, looking for the Lord’s concluding counsel in this revelation. (The word *order* as used in verse 11 means to arrange.)

Complete the following principle based on what you learned from verse 11: **If we are \_\_\_\_\_ and avoid \_\_\_\_\_, then the Lord will arrange all things \_\_\_\_\_.**



4. Answer the following questions in your scripture study journal:

- What are some ways you can be wise in your choices?
- What do you think it means that the Lord “will order all things for your good” (D&C 111:11)?
- When have you seen an example of this principle?



5. Look back at assignment 1 for today’s lesson in your scripture study journal—the list of things that bring stress or anxiety into your life. Write a sentence or two explaining what you have learned from your study of Doctrine and Covenants 111 that can help you with the challenges you face.



6. Write the following at the bottom of today’s assignments in your scripture study journal:

*I have studied Doctrine and Covenants 111 and completed this lesson on (date).*

*Additional questions, thoughts, and insights I would like to share with my teacher:*

# Doctrine and Covenants 112

## Introduction

On July 23, 1837, the Prophet Joseph Smith received the revelation in Doctrine and Covenants 112 in behalf of Thomas B. Marsh, who was then President of the Quorum of the Twelve Apostles. In this revelation Thomas Marsh was counseled regarding his own responsibilities and those of the Quorum of the Twelve.

## Doctrine and Covenants 112:1–13

*The Lord gives personal counsel and promises blessings to Thomas B. Marsh*

Think about times when you have felt angry, frustrated, offended, or jealous as a result of your interactions with others. An early Apostle, Thomas B. Marsh, faced a situation that may have led him to experience similar feelings.

Soon after he was called to be an Apostle in 1835, Thomas B. Marsh was appointed President of the Quorum of the Twelve Apostles. In the spring of 1837, President Marsh learned that one of the Apostles, Parley P. Pratt, was planning a mission to England without President Marsh’s supervision. President Marsh, who was in Missouri, wrote to Elder Pratt and the other members of the Twelve and invited them to meet him in Kirtland, Ohio, on July 24, 1837, so they could be unified in their plans for missions. However, a month before that meeting took place, two other members of the quorum, Heber C. Kimball and Orson Hyde, departed for England after receiving mission calls from the Prophet Joseph Smith. President Marsh was apparently upset that members of the Twelve were proceeding to preach the gospel in England without the quorum being unified and without his involvement.

In this situation, what could President Marsh do to avoid feeling angry, frustrated, offended, or jealous? What are some dangers of allowing such feelings to govern our thoughts and actions?

Brigham Young, who was a member of the Quorum of the Twelve Apostles at the time, persuaded President Marsh to meet with the Prophet Joseph Smith. In response to President Marsh’s concerns, the Lord gave the revelation recorded in Doctrine and Covenants 112 to the Prophet Joseph Smith.

Read Doctrine and Covenants 112:1–3, looking for the warnings that the Lord gave to Thomas B. Marsh. As you read, it might be helpful to know that the word *abased* in verse 3 indicates that President Marsh had humbled himself. What warnings did the Lord give to him? What good things did the Lord say Thomas had done?

In Doctrine and Covenants 112:4–10, the Lord gave further counsel to Thomas B. Marsh and assured him that he could accomplish great things with the Lord’s help.



**1. Read Doctrine and Covenants 112:4–10.**

In your scripture study journal, list the promises the Lord made to Thomas B. Marsh. (In verse 5, the word *contend* does not mean to be angry or contentious; it means to labor diligently to preach the gospel.)

Complete the following “if–then” statement based on what you learn from Doctrine and Covenants 112:10:  
**If we** \_\_\_\_\_,  
**then the Lord will** \_\_\_\_\_.

(You may want to mark this principle in your scriptures.)



**2. Answer the following questions in your scripture study journal:**

- a. Why do you think humility helps us receive the Lord’s direction?
- b. When have you felt guided by the Lord after humbling yourself?

### Name Substitution

As you read, try inserting your name for names identified in the scriptures. This practice can help you engage in meaningful scripture study and see how certain passages may relate to you. You can apply the Lord’s statement “What I say unto one I say unto all” (D&C 93:49) as you read many scripture passages. Try this study skill with Doctrine and Covenants 112:1–11.



When the Lord gave this revelation in July 1837, the Church was experiencing disunity, contention, and apostasy. Pride and greed led some members of the Church to openly criticize the Prophet Joseph Smith and question his authority. These challenges were partly a result of financial difficulties among the Saints in Kirtland, Ohio. Because of widespread economic problems, later referred to as the Panic of 1837, many banks failed throughout the United States. The Kirtland Safety Society, a financial institution established by Church leaders, also failed in the fall of 1837. Two hundred investors lost almost everything they had invested, with Joseph Smith suffering the greatest losses. Even though the Kirtland Safety Society was not funded by the Church, some of the Saints considered it a Church bank or the Prophet's bank, and they blamed Joseph Smith for their financial problems. Some even began calling him a fallen prophet. But many others continued in the faith and stayed true to the Prophet, even though they lost money because of the failure of the Kirtland Safety Society. (See *Church History in the Fulness of Times Student Manual*, 2nd ed. [Church Educational System manual, 2003], 171–73.)

Some Church members, including some members of the Quorum of the Twelve Apostles, even sought to remove Joseph Smith as President of the Church.

Read Doctrine and Covenants 112:11–13, looking for what the Lord instructed Thomas B. Marsh to do to help other members of the Quorum of the Twelve Apostles who were struggling.

### Doctrine and Covenants 112:14–34

*The Lord teaches Thomas B. Marsh concerning the duties of the Twelve Apostles*

President Marsh was in an important position and had many responsibilities given him from the Lord.

 **3.** Answer the following question in your scripture study journal: What can help you to be humble when you receive recognition or important responsibilities?

The Lord helped Thomas B. Marsh recognize the importance of his responsibilities as President of the Quorum of the Twelve Apostles while continuing to remind him to be humble. Complete the following chart as you study Doctrine and Covenants 112:14–22, 28–33.

Doctrine and Covenants 112:14–22, 28–33	
Phrases emphasizing the importance of President Marsh's responsibilities:	
Phrases reminding Thomas Marsh of the need to be humble:	

 **4.** Complete the following activities in your scripture study journal:

- According to verses 16–17, what priesthood keys are held by the President of the Quorum of the Twelve Apostles? Mark in your scriptures the doctrine you learn, and write it down in your scripture study journal.
- Write a principle you learn in verses 30–32 about the priesthood keys President Marsh held.

Consider marking the following doctrine found in Doctrine and Covenants 112:30–32: **The keys of the priesthood have been restored for the last time in the dispensation of the fulness of times.**

A dispensation is a period of time when the Lord reveals His doctrines, ordinances, and priesthood. It is a period in which the Lord has at least one authorized

servant on the earth who bears the holy priesthood and who has a divine commission to dispense the gospel and to administer the ordinances thereof. (See Bible Dictionary, “Dispensations.”)

Ponder the following question: In Doctrine and Covenants 112:15, 30, what does the Lord say about the relationship between Thomas Marsh’s responsibilities as President of the Quorum of the Twelve Apostles and the responsibilities of the Prophet Joseph Smith?

Thomas B. Marsh struggled to follow the counsel he received in this revelation.

Not long after the revelation in Doctrine and Covenants 112 was given, Thomas B. Marsh told Vilate Kimball (Heber C. Kimball’s wife) that Heber would not be effective on his mission. President Marsh apparently felt that because proclaiming the gospel abroad was his responsibility, the door to missionary work in England could not be opened until he either sent someone or went himself.

Think about how this incident illustrates that President Marsh may have struggled to be humble.



President Dieter F. Uchtdorf of the First Presidency explained how we can be more humble and avoid pride:

“Humility does not mean convincing ourselves that we are worthless,

meaningless, or of little value. Nor does it mean denying or withholding the talents God has given us. We don’t discover humility by thinking less *of* ourselves; we discover humility by thinking less *about* ourselves. It comes as we go about our work with an attitude of serving God and our fellowman.

“Humility directs our attention and love toward others and to Heavenly Father’s purposes. Pride does the opposite. Pride draws its energy and strength from the deep wells of selfishness. The moment we stop obsessing with ourselves and lose ourselves in service, our pride diminishes and begins to die” (“Pride and the Priesthood,” *Ensign* or *Liahona*, Nov. 2010, 58).

 **5.** Explain to a family member or friend what you have been learning about humility. Write the person’s name in your scripture study journal.

Read Doctrine and Covenants 112:34, looking for what Thomas Marsh needed to do to receive these blessings.

Finish the following principle: **We must** \_\_\_\_\_

**to receive the Lord’s promised blessings.**

The following account summarizes Thomas B. Marsh’s eventual falling away from and return to the Church:

For a time, President Marsh followed the counsel he had received. He worked to strengthen the Church and sustain Joseph Smith. However, he soon returned to his contentious feelings about the way the Church was led. These feelings combined with concerns about conflicts between disobedient and aggressive Church members and their neighbors in Missouri. In September 1838, while he was beset by this spirit of apostasy, his wife, Elizabeth, became involved in a dispute. She and another woman, both members of the Church, had agreed to regularly exchange milk to have enough to make cheese, but Sister Marsh was accused of violating her agreement by keeping the part of the milk that was richest in cream. The matter was brought before Church leaders more than once. It was even brought before the First Presidency. Each time, it was decided that Sister Marsh was at fault. President Marsh was angry and unsatisfied with these decisions (see George A. Smith, “Discourse,” *Deseret News*, Apr. 16, 1856, 44). While this situation did not lead him to leave the Church, it compounded with his other frustrations. He became increasingly critical of other Church leaders, and he eventually turned against the Saints. He later recalled, “I became jealous of the Prophet . . . and overlooked everything that was right, and spent all my time in looking for the evil” (“Remarks,” *Deseret News*, Sept. 16, 1857, 220).

Eighteen years after he left the Church, Thomas Marsh humbly wrote a letter to Heber C. Kimball, asking for forgiveness and permission to rejoin the Church. He explained what he learned through his mistakes: “The Lord could get along very well without me and He has lost nothing by my falling out of the ranks; But O what have I lost?!” (Thomas B. Marsh letter to Heber C. Kimball, May 5, 1857, Brigham Young Collection, Church History Library, as quoted in Kay Darowski, “The Faith and Fall of Thomas Marsh,” *Revelations in Context* [Mar. 19, 2013]; history.lds.org).

 **6.** In your scripture study journal, summarize what you have learned from your study today. Select one way that you can be more humble and faithful, and write a goal to act upon it.

 **7.** Write the following at the bottom of today’s assignments in your scripture study journal:

*I have studied Doctrine and Covenants 112 and completed this lesson on (date).*

*Additional questions, thoughts, and insights I would like to share with my teacher:*



# The Church Moves to Northern Missouri

## Introduction

In 1837 and 1838, the Prophet Joseph Smith and other Church leaders nobly led the Church through a difficult season. As a result of economic distress, greed, faultfinding, and persecution, an estimated 10 or 15 percent of the Saints in Kirtland, Ohio, apostatized, including some prominent Church leaders. Faithful Saints in Ohio began moving to join those in northern Missouri. Far West, Missouri, became the headquarters of the Church until the Saints were forced to leave the city in early 1839. This lesson can help you understand and learn from historical events and give you insights into the revelations received during this period.

## Difficulties and Apostasy in Kirtland, Ohio

Ponder the following question: Do difficulties and trials help strengthen your faith, or does your faith weaken during those times?

In 1837 and 1838, a period of trials led many of the Saints to face this question. While some of their trials were the results of persecution from outside the Church, many were the results of contention within the Church. As you study this lesson, ponder how our reaction to trials can either strengthen or weaken our faith in Jesus Christ.

As you read the following historical summary, consider what principles you can learn from the events described:

In 1837, the Saints in Kirtland, Ohio, experienced some financial problems. To help the Saints be more self-sufficient in their finances, the Prophet Joseph Smith and other Church leaders established the Kirtland Safety Society, a company similar to a bank. Because of a widespread economic depression during this time, many banks failed throughout the nation. The Kirtland Safety Society also failed in the fall of 1837. Two hundred investors in the bank lost almost everything, with Joseph Smith sustaining the greatest losses. Even though the Kirtland Safety Society was not funded by the Church, some of the Saints considered it a Church bank or the Prophet's bank and blamed Joseph for their financial problems. Some even began calling him a fallen prophet. But despite the bank's failure, many others who lost money remained faithful and stayed true to the Prophet. (See *Church History in the Fulness of Times Student Manual*, 2nd ed. [Church Educational System manual, 2003], 171–73.)

A spirit of apostasy and faultfinding spread among many of the Saints. Brigham Young described an occasion when some of the Church members, including Church leaders, met to renounce Joseph Smith and appoint a new prophet: "Several of the Twelve, the witnesses to the Book of Mormon, and others of the Authorities of the Church, held a council in the upper room of the Temple. The question before them was to ascertain how the Prophet Joseph could be deposed, and David Whitmer appointed President of the Church. . . . I rose up, and in a plain and forcible manner told them that Joseph was a Prophet, and I



Kirtland, Ohio, in relation to sites in northern Missouri

knew it, and that they might rail and slander him as much as they pleased, they could not destroy the appointment of the Prophet of God, they could only destroy their own authority, cut the thread that bound them to the Prophet and to God and sink themselves to hell”

(*Manuscript History of Brigham Young, 1801–1844*, ed. Elden Jay Watson [1968], 15–16).



1. Answer the following questions in your scripture study journal:

- What truths can we learn from these historical events?
- What would you have done to remain faithful to the Prophet during this time of faultfinding? When has enduring a trial with faith strengthened your faith in Jesus Christ?
- In what ways has following the prophet been a spiritual protection for you?

By June 1838, approximately 200 or 300 apostates had left the Church, including four Apostles, the Three Witnesses of the Book of Mormon, and a member of the First Presidency (see *Church History in the Fulness of Times*, 177). However, most of the Saints responded to this period of testing with faith, much like Brigham Young did. They were strengthened by the Lord, and they remained true to their testimonies. Several of those who left the Church during this period of apostasy later returned and requested that they be reunited again with the Lord’s Church. Among them were Oliver Cowdery, Martin Harris, Luke Johnson, and Frederick G. Williams.

In the midst of these struggles in Kirtland, a few apostates sought to kill Joseph Smith. Luke Johnson, who had himself apostatized from the Church, had enough integrity to warn the Prophet of the plot. Joseph Smith and Sidney Rigdon left Kirtland in January 1838. They were pursued for days, but the Lord protected them. They arrived with their families in Far West, Missouri, in March 1838.

## Northern Missouri

Look at the state of Missouri on the map at the beginning of this lesson. When the Saints were driven from Jackson County, Missouri, in 1833, the citizens of a neighboring county welcomed them and gave them

temporary relief, anticipating that the Saints would stay for only a short time. However, after the Saints had lived there for almost three years, these citizens began pressuring them to leave the county.

As you read the following historical summary, consider what principles you can learn from the events described:

In 1837, John Whitmer and William W. Phelps, the two counselors in the Missouri stake presidency, used Church funds to purchase land in a place known as Far West in northern Missouri. However, when they offered parcels of land to incoming Saints, they sold the land for a small profit, which they kept for themselves. Nonetheless, the high council in Missouri forgave them and appointed others to distribute the land. However, John and William continued to try to profit from the sale of lands. In 1838, the high council excommunicated them. (See *Church History in the Fulness of Times*, 183–85.)

Joseph Smith upheld the council’s action, and William was offended. In November 1838, he signed an affidavit against the Prophet. This affidavit contributed to Joseph and others being arrested and thrown into Liberty Jail for the winter.

In jail, the Prophet Joseph Smith and those with him suffered immensely, not only from the brutal conditions of their imprisonment but also from reports of the Saints being driven from their homes and abused in many ways. The Missouri mobs, unchecked by the governor, destroyed property and killed 17 people at a mill owned by a man named Jacob Haun.

William W. Phelps suffered spiritually for his actions, and he wrote Joseph a letter asking for forgiveness. The Prophet wrote back:

“It is true, that we have suffered much in consequence of your behavior—the [bitter cup], already full enough for mortals to drink, was indeed filled to overflowing when you turned against us. . . .

“However, the cup has been drunk, the will of our Father has been done, and we are yet alive, for which we thank the Lord. . . .

“Believing your confession to be real, and your repentance genuine, I shall be happy once again to give you the right hand of fellowship, and rejoice over the returning prodigal. . . .

““Come on, dear brother, since the war is past, / For friends at first, are friends again at last” (in *History of the Church*, 4:163–64).



A portion of Joseph Smith's letter to William W. Phelps

Why is it important for us to think about how our actions or words reflect on the Church?

In 1838 the actions and words of some Church members added to the negative feelings some citizens of Missouri had toward Latter-day Saints. As you read the following historical summary, look for things that some of the Saints said or did that hurt the Church and its members. Consider marking what you find.

In 1837 and 1838 some disaffected and excommunicated members of the Church living among the Saints in Far West, Missouri, began to bring lawsuits against the Church and to harass the Church. Some of the Saints began to grow impatient with these dissenters. In June 1838, Sidney Rigdon spoke heatedly in what has become known as the “Salt Sermon.” He referenced Matthew 5:13 and said that if the salt loses its savor, it is good for nothing and should be cast out, implying that those who had left the Church should be cast out from among the Saints. Additionally, 84 Church members signed a document ordering the apostates to leave the county. Two weeks later, on July 4, Sidney gave a speech where he promised that the Saints would defend themselves even if it came to a “war of extermination.” Though both of these speeches seemed to contradict the Lord’s instruction to “sue for peace” (D&C 105:38), both speeches were published and caused great alarm among non-Latter-day Saints. (See *Church History in the Fulness of Times*, 191–92.)



**2.** Answer the following questions in your scripture study journal:

- a. Why is it difficult to forgive a friend who has betrayed you and caused you to suffer?
- b. What principle can we learn from Joseph Smith’s example? (This principle might remind you of the scripture mastery passage in Doctrine and Covenants 64:9–11. You may want to review that passage to see how it relates to the experience of Joseph Smith and W. W. Phelps.)
- c. What other lessons can we learn from this account?



**3.** Choose one of the principles you identified from these two historical summaries. In your scripture study journal, write about when you have seen an example of it in your life or in the life of someone you know.

## Events Leading to the Saints’ Expulsion from Northern Missouri

Have you ever seen a member of the Church make a choice that resulted in another person having a negative impression of the Church? You may also want to consider how your own actions have influenced others’ impressions of the Church.

On August 6, 1838, a group of Saints tried to vote in Gallatin, Missouri, but were attacked by a group of Missourians. The Saints fought back, and men on both sides were injured. This incident led to additional conflicts and threats and increased the misunderstanding between the Latter-day Saints and their neighbors in Missouri. (See *Journals, Volume 1: 1832–1839*, vol. 1 of the Journals series of *The Joseph Smith Papers* [2008], 298–301.)

During this time a convert named Sampson Avard administered secret oaths to those who would join him in forming a band of marauders called the Danites. Avard instructed them to rob and plunder the Missourians, saying that this would help build up the kingdom of God.

Avard convinced his followers that his directions were coming from the First Presidency. The truth was later discovered, and Avard was excommunicated. Avard’s actions caused significant damage to the image of the Church and helped lead to the Prophet’s imprisonment in Liberty Jail.



In October 1838 there was a battle between some members of the Church and Missouri militiamen. Exaggerated reports of the battle reached Governor Boggs, who then issued an extermination order: “The Mormons must be treated as enemies and *must be exterminated* or driven from the state, if necessary for the public good” (in *History of the Church*, 3:175). Soon, the city of Far West was surrounded by a militia that outnumbered the Saints’ forces five to one. The Prophet Joseph Smith and other Church leaders were imprisoned in Liberty Jail, where they remained all winter. The rest of the Saints were forced to leave the state. (See *Church History in the Fulness of Times*, 199–200, 204, 208.)



The Saints were forced to leave Far West, Missouri.

One principle we could identify from this time period is that **our actions and words can influence how others view the Church of Jesus Christ.**

Why do you think it is important for us to recognize that the actions of some early Church members contributed to the negative opinions some Missourians had about the Church?

Although our poor choices can influence others to view the Church negatively, we can also help others have a positive view of the Church through our words and actions.

 **4.** In your scripture study journal, write about a time when you have seen someone’s words or actions influence someone to have a positive view of the Church.

Watch for ways to represent the Church of Jesus Christ positively during the next week. As you do, the Lord will bless you.

One of the main principles we can learn from this time in Church history is that **as we choose to respond to trials with faith rather than doubt, our testimonies can be strengthened.**

 **5.** Answer the following question in your scripture study journal: What will I do differently because of the doctrines and principles I learned today?

 **6.** Write the following at the bottom of today’s assignments in your scripture study journal:

*I have studied “The Church Moves to Northern Missouri” lesson and completed this lesson on (date).*

*Additional questions, thoughts, and insights I would like to share with my teacher:*

## UNIT 25: DAY 2

# Doctrine and Covenants 113–14

## Introduction

After arriving in Far West, Missouri, in March 1838, the Prophet Joseph Smith received the revelation recorded in Doctrine and Covenants 113. In the revelation, the Lord answered questions about passages from the book of Isaiah. Joseph Smith received the revelation recorded in Doctrine and Covenants 114 on April 17, 1838. In this revelation the Lord directed David W. Patten, a member of the Quorum of the Twelve Apostles, to prepare to serve a mission.

## Doctrine and Covenants 113

*The Lord answers questions about passages in the book of Isaiah*

Do you ever struggle to understand what you read in the scriptures?

Some prophecies in the scriptures use symbols that are difficult to understand. In Far West, Missouri, some brethren asked the Prophet Joseph Smith to clarify passages in the book of Isaiah. The Lord’s revealed answers to those questions are recorded in Doctrine and Covenants 113.

### Symbolism

You can study a symbol in the scriptures by exploring its nature and pondering its attributes. Footnotes, the Bible Dictionary, and the Topical Guide or Guide to the Scriptures can help with the interpretation of some symbols. Try using this skill as you study Doctrine and Covenants 113.





Isaiah

 **1.** In your scripture study journal, list the questions in Doctrine and Covenants 113 and summarize the Lord's answers.

In Doctrine and Covenants 113:1–2, the meaning of the stem is clear. The following information may help increase your understanding of that symbol: Jesus Christ descended from the house of Jesse, the father of David. The word *stem* in Isaiah 11:1 is translated from a Hebrew word that refers to the trunk or stump of a tree—either a tree that has been cut down or a tree that has been planted.

Ponder the meanings of the rod and the root, mentioned in Doctrine and Covenants 113:3–6. Consider the following interpretation shared by Elder Bruce R. McConkie of the Quorum of the Twelve Apostles: “Are we amiss in saying that the prophet here mentioned is Joseph Smith, to whom the priesthood came, who received the keys of the kingdom, and who raised the ensign for the gathering of the Lord’s people in our dispensation? And is he not also the ‘servant in the hands of Christ, who is partly a descendant of Jesse as well as of Ephraim, or of the house of Joseph, on whom there is laid much power’? (D&C 113:4–6.) Those whose ears are attuned to the whisperings of the Infinite will know the meaning of these things” (*The Millennial Messiah: The Second Coming of the Son of Man* [1982], 339–40).

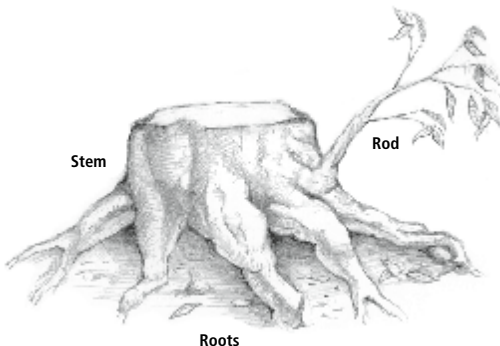

What are some things Joseph Smith has done as “a servant in the hands of Christ” (D&C 113:4)?

As you consider the meaning of the roots, study Doctrine and Covenants 113:5–6.

How might the roots represent Joseph Smith?

Complete the following statement of doctrine based on what you learn from verse 6: **Joseph Smith received the keys of the kingdom, for \_\_\_\_\_ and for \_\_\_\_\_ in the last days.**

You may want to cross reference verse 6 with Doctrine and Covenants 110:11.

After the Lord revealed answers to questions about Isaiah 11, Elias Higbee asked questions concerning Isaiah 52.

Study Doctrine and Covenants 113:7–10, and complete the following chart:

Doctrine and Covenants 113:7–8	Doctrine and Covenants 113:9–10
What should we “put on”?	What does the Lord promise to those who return to Him?
What do you think this means?	What do you think this means to the scattered people of Israel?

 **2.** In your scripture study journal, list ways the Lord can provide guidance and strength for people who are striving to return to Him.

## Doctrine and Covenants 114

*The Lord commands David W. Patten to prepare to serve a mission*

One person the Lord chose to help strengthen Zion was a man named David W. Patten.

David W. Patten joined the Church on June 15, 1832. He was ordained an Apostle in 1835. He had the gift of healing, and he was a man of great courage and power. He was fearless in his defense of the faith and of the Prophet Joseph Smith. In defending the Saints against the mobs in Missouri, David Patten

was known as “Captain Fear Not.” (See Lycurgus A. Wilson, *Life of David W. Patten: The First Apostolic Martyr* [1900], 5–8, 14–17, 48–49, 62.)

Elder Patten asked the Prophet Joseph Smith to seek a revelation on his behalf. Read Doctrine and Covenants 114:1, looking for what the Lord wanted Elder Patten to do.

In the fall of 1838, six months after the revelation in which Elder Patten was commanded to prepare for a mission, he was involved in the battle at Crooked River, located near the Saints’ settlements in west central Missouri. On October 25, 1838, mobs attacked the homes of some of the Saints, ordering the members to leave the state and taking three men prisoners. On hearing the report that the mob intended to murder the prisoners that night, the Saints’ militia organized two groups to rescue the prisoners. Elder David W. Patten led one of the groups. Near dawn, as Elder Patten’s company approached the Crooked River to cross, members of the mob, who had been hiding nearby, opened fire. A quick fight ensued, and several men on each side were wounded, including Elder Patten.



The battle at Crooked River, Missouri

Elder Patten died several hours later. His faith in the restored gospel was such that he had once expressed to the Prophet Joseph Smith a desire to die the death of a martyr. “The Prophet, greatly moved, expressed extreme sorrow, ‘for,’ said he to David, ‘when a man of your faith asks the Lord for anything, he generally gets it.’” At Elder Patten’s funeral in Far West, two days after the battle, Joseph Smith eulogized him: “There lies a man that has done just as he said he would—he has laid down his life for his friends.” (See *Church History in the Fulness of Times Student Manual*, 2nd ed. [Church Educational System manual, 2003], 199–200; quoting *Life of David W. Patten*, 53; *History of the Church*, 3:175.)

At the time Elder Patten died, he was preparing himself, through his faithfulness, to serve a mission. He was also concerned about his fellow Saints, including some members of the Quorum of the Twelve Apostles, who had not been faithful. When he was on his deathbed, he exclaimed, “O that they were in my situation! For I feel that I have kept the faith, I have finished my course, henceforth there is laid up for me a crown, which the Lord, the righteous Judge, will give me [see 2 Timothy 4:7–8].” To his wife, he said, “Whatever you do else, O do not deny the faith” (quoted by Heber C. Kimball, in *Life of David W. Patten*, 69).

One truth we can learn from David Patten’s experience is that **if we heed the Lord’s direction, we will be prepared for whatever He has planned for us.**

 **3. Answer the following question in your scripture study journal: When have you followed the Lord’s counsel and found that it prepared you for something you had not expected? If you have not had this experience, discuss the question with a family member or friend. Write what you learn from him or her.**

Read Doctrine and Covenants 114:2, looking for what the Lord said will happen when some people deny His name. (In this verse, the term *bishopric* refers to a person’s responsibility, not to a bishop and his counselors. See Psalm 109:9; Acts 1:20; Bible Dictionary, “Bishop.”)

When some members of the Quorum of the Twelve Apostles did not remain faithful, others were called to serve in their places. These new Apostles included John Taylor and Wilford Woodruff, who faithfully served missions in England and brought thousands of souls to the knowledge of the restored gospel.



John Taylor

Wilford Woodruff



4. In your scripture study journal, write a short paragraph describing what you can do to follow the Lord's counsel and fulfill the expectations He has for you.



5. Write the following at the bottom of today's assignments in your scripture study journal:

*I have studied Doctrine and Covenants 113–14 and completed this lesson on (date).*

*Additional questions, thoughts, and insights I would like to share with my teacher:*

## UNIT 25: DAY 3

# Doctrine and Covenants 115–16

### Introduction

On April 26, 1838, the Prophet Joseph Smith received the revelation contained in Doctrine and Covenants 115. In it the Lord revealed the name of the Church, commanded the Saints to “arise and shine forth” (D&C 115:5), and revealed His will concerning the temple in Far West. On May 19, 1838, the Prophet Joseph Smith received the revelation found in Doctrine and Covenants 116, which identified Spring Hill, Missouri, as Adam-ondi-Ahman.

### Doctrine and Covenants 115:1–6

*The Lord commands the members of His Church to “arise and shine forth”*

What are the names of some companies or organizations that you are familiar with? What do the names of these organizations communicate? Who leads these organizations? What do these organizations do?

Think of the name and logo of the Church. As you study Doctrine and Covenants 115, look for what the name of the Church communicates about who leads the Church and what the Church is.

## THE CHURCH OF JESUS CHRIST OF LATTER-DAY SAINTS

Doctrine and Covenants 115:1–3 tells us that this revelation was given through the Prophet Joseph Smith to all members of the Church. Read Doctrine and Covenants 115:4, looking for the name the Lord designated for His Church.

Look carefully at each word in the name of the Church and think about why each word is significant.

Read the following explanation by Elder M. Russell Ballard of the Quorum of the Twelve Apostles:



“I have thought a lot about why the Savior gave the nine-word name to His restored Church. It may seem long, but if we think of it as a descriptive overview of what the Church is, it suddenly becomes wonderfully brief, candid, and

straightforward. How could any description be more direct and clear and yet expressed in such few words?

“Every word is clarifying and indispensable. The word *The* indicates the unique position of the restored Church among the religions of the world.

“The words *Church of Jesus Christ* declare that it is His Church. . . .

“*Of Latter-day* explains that it is the same Church as the Church that Jesus Christ established during His mortal ministry but restored in these latter days. . . .

“*Saints* means that its members follow Him and strive to do His will, keep His commandments, and prepare once again to live with Him and our Heavenly Father in the future. *Saint* simply refers to those who seek to make their lives holy by covenanting to follow Christ” (“The Importance of a Name,” *Ensign* or *Liahona*, Nov. 2011, 80).



1. Answer the following questions in your scripture study journal:

- What are some important truths communicated by the name of the Church?
- Who is the head of the Church? Whom does He instruct and inspire on the earth to lead the Church?

Read Doctrine and Covenants 115:5, looking for what the Lord expects of those who belong to His Church.



2. Answer the following question in your scripture study journal: What do you think it means to “arise and shine forth” (D&C 115:5) as members of The Church of Jesus Christ of Latter-day Saints?

What blessing will come as members of the Church follow the Lord's counsel to arise and shine forth? To answer this question, use verse 5 to help you complete



the following statement: **If we arise and shine forth, our light will be** \_\_\_\_\_.  
Consider marking this principle in verse 5.

 **3. Answer the following questions in your scripture study journal:**

- a. What do you think it means that our light, or example, can be “a standard for the nations” (D&C 115:5)? (As you answer this question, it may help to know that a *standard* is flag or banner that serves as a rallying point or inspirational symbol.)
- b. How can following the Savior’s commandment to arise and shine forth attract others to The Church of Jesus Christ of Latter-day Saints?

President James E. Faust of the First Presidency shared the following account of a member of the Church who followed this principle:



“Some years ago, Constance, a student nurse, was assigned to try and help a woman who had injured her leg in an accident. The woman refused medical help because she had had a negative experience with someone at the hospital. She was

afraid and had become something of a recluse. The first time Constance dropped by, the injured woman ordered her out. On the second try, she did let Constance in. By now the woman’s leg was covered with large ulcers, and some of the flesh was rotting. But still she didn’t want to be treated.

“Constance made it a matter of prayer, and in a day or two the answer came. She took some foaming hydrogen peroxide with her for the next visit. As this was painless, the old woman let her use it on her leg. Then they talked about more serious treatment at the hospital. Constance assured her the hospital would make her stay as pleasant as possible. In a day or two the woman did get the courage to enter the hospital. When Constance visited her, the woman smiled as she said, ‘You convinced me.’ Then, quite unexpectedly, she asked Constance, ‘What church do you belong to?’ Constance told her she was a member of The Church of Jesus Christ of Latter-day Saints. The woman said: ‘I knew it. I knew you were sent to me from the first day that I saw you. There was a light in your face that I had noticed in others of your faith. I had to put my trust in you.’

“In three months’ time that festering leg was completely healed. Members of the ward where the old woman lived remodeled her house and fixed up her yard. The missionaries met with her, and she was baptized soon after. [See Constance Polve, “A Battle Won,” *New Era*, Apr. 1980, 44–45.] All of this because

she noticed the light in that young student nurse’s face” (“The Light in Their Eyes,” *Ensign* or *Liahona*, Nov. 2005, 22).

What did Constance do to arise and shine forth? How was the light in her face a standard for the woman? How was the woman blessed because of the light she saw?

 **4. Answer the following questions in your scripture study journal:**

- a. Whom do you know that is a good example of arising and shining forth?
- b. How has his or her example been a blessing to you?

The Prophet Joseph Smith was a good example of what it means to arise and shine forth. Shortly after this revelation was received, Joseph began writing his history that is now contained in the Pearl of Great Price.



A page from the Prophet Joseph Smith’s history

 **5. Answer the following questions in your scripture study journal:**

- a. How is Joseph Smith’s history, including his testimony of the First Vision, a standard for the nations?
- b. How is it a standard for you?



Read Doctrine and Covenants 115:6, looking for blessings that are promised to those who gather with the Church in the stakes of Zion.

One truth we learn from this verse is the following: **We gather to the stakes of Zion for strength and for refuge.** In what ways do you think gathering together as Saints provides us with protection, safety, or refuge?

## Doctrine and Covenants 115:7–19

*The Lord commands the Saints to establish the city of Far West and to build a temple*

One of the ways we can obtain the Lord's protection and safety is by serving and worshipping Him in the temple. After the Saints began moving to Far West, Missouri, in 1836, Church leaders made plans to build a temple similar to the one in Kirtland, Ohio. Even though some preliminary excavation was done, further construction was suspended until Joseph Smith could receive additional instruction from the Lord. The Lord revealed His will concerning the temple as part of the revelation in Doctrine and Covenants 115.

In Doctrine and Covenants 115:7–16, the Lord revealed that a temple should be built in Far West according to the pattern He would give to the First Presidency. The Lord also counseled the leaders of the Church not to go into debt to build the temple.

Read Doctrine and Covenants 115:17–19, looking for what the Lord wanted the Saints to do under Joseph Smith's direction in Far West and in the neighboring regions.

One of the principles we learn from verse 19 is that **the President of the Church holds the keys to direct the Lord's work upon the earth.**

## Doctrine and Covenants 116

*The Lord designates the location of Adam-ondi-Ahman*

The Prophet Joseph Smith followed the Lord's counsel in Doctrine and Covenants 115:18 and explored the areas surrounding Far West. Read the section introduction for Doctrine and Covenants 116, looking for the name of the location the Prophet explored.



Adam-ondi-Ahman

Read Doctrine and Covenants 116:1, looking for what the Lord revealed about Spring Hill. You may want to turn to the map and picture of Adam-ondi-Ahman in the back of your scriptures (see Church History map 5, "The Missouri, Illinois, and Iowa Area of the USA," and Church history photograph 10, of Adam-ondi-Ahman).

This revelation identifies the location of the future fulfillment of a prophecy made anciently by the prophet Daniel (see Daniel 7:9–10, 13–14). That prophecy describes a latter-day event in which the Savior and Adam will visit the earth and preside over a meeting before the Second Coming of Jesus Christ to all the world (see D&C 27:5–14).

Ponder or sing the hymn "Adam-ondi-Ahman" (*Hymns*, no. 49, in the English hymnbook).

*This earth was once a garden place,  
With all her glories common,  
And men did live a holy race,  
And worship Jesus face to face,  
In Adam-ondi-Ahman.*

*We read that Enoch walked with God,  
Above the pow'r of mammon,  
While Zion spread herself abroad,  
And Saints and angels sang aloud,  
In Adam-ondi-Ahman.*

*Her land was good and greatly blest,  
Beyond all Israel's Canaan;  
Her fame was known from east to west,  
Her peace was great, and pure the rest  
Of Adam-ondi-Ahman.*

*Hosanna to such days to come,  
The Savior's second coming,  
When all the earth in glorious bloom  
Affords the Saints a holy home,  
Like Adam-ondi-Ahman.*



6. Write the following at the bottom of today's assignments in your scripture study journal:

*I have studied Doctrine and Covenants 115–16 and completed this lesson on (date).*

*Additional questions, thoughts, and insights I would like to share with my teacher:*

## UNIT 25: DAY 4

# Doctrine and Covenants 117–20

### Introduction

On July 8, 1838, in Far West, Missouri, the Prophet Joseph Smith received four revelations that are now recorded in Doctrine and Covenants 117–20. In the first of these revelations (D&C 117), the Lord commanded William Marks and Newel K. Whitney to settle their business in Kirtland, Ohio, and join the faithful Saints who were gathering in Far West. The Lord also commanded Oliver Granger to go to Kirtland as a representative of the First Presidency. In the second revelation (D&C 118), the Lord called new Apostles to fill the places of those who had fallen away, and He called all of the members of the Quorum of the Twelve to serve missions in Great Britain. In the third and fourth revelations, recorded in Doctrine and Covenants 119 and 120, the Lord taught the doctrine of tithing and revealed guidelines for Church leaders to determine how tithing funds are used.

### Doctrine and Covenants 117:1–11

*The Lord commands William Marks and Newel K. Whitney to settle their business speedily and leave Kirtland*

In the first part of Doctrine and Covenants 117, the Lord spoke to William Marks and Newel K. Whitney. William Marks was the stake president in Kirtland, Ohio. He owned a bookselling business. Newel K. Whitney was the bishop in Kirtland. He was a successful business owner, and he consecrated much of his property to the Church.



On April 26, 1838, the Lord commanded the Saints to gather in Far West, Missouri, and other places (see D&C 115:17–18). On July 6, 1838, a group known as the Kirtland Camp, consisting of over 500 Saints from the Kirtland area, departed for Missouri (see *Church History in the Fulness of Times Student Manual*, 2nd ed. [Church Educational System manual, 2003], 179). President Marks and Bishop Whitney remained in Kirtland.

In Doctrine and Covenants 117:1–3, we read that the Lord commanded President Marks and Bishop Whitney to settle their business speedily and to leave Kirtland. They were to make this journey before the Lord would send snow to the area. In other words, they would need to leave within about four months.

As you read the Lord's words in Doctrine and Covenants 117:4–5, you will see that these men were overly concerned about properties in Kirtland.

Notice the following question in verse 4: "What is property unto me?" Read Doctrine and Covenants 117:5–8, looking for reasons why the Lord would say this. (It may be helpful to know that the phrase "plains of Olaha Shinehah" refers to the area around Adam-ondi-Ahman in Missouri.)

Imagine you have a large pitcher of your favorite drink sitting in front of you and a large, empty drinking glass. Now imagine that someone pours a small drop of the drink into your drinking glass. Which would you rather have, a full glass or just a drop? Why?

What do you think it means to "covet . . . the drop, and neglect the more weighty matters"? (D&C 117:8). To covet means to desire something someone else has. How were the benefits of preserving the properties in Kirtland just a "drop" compared to the benefits of obeying the Lord's command to gather in Missouri?



1. In your scripture study journal, summarize what the Lord taught these men about the property they were coveting compared to His power to bless them.

From Doctrine and Covenants 117:5–8, we can identify a principle about what happens when we covet temporal things. One way to express this principle is that **coveting temporal things can cause us to neglect weightier matters.**



2. Answer the following questions in your scripture study journal:

- a. What are some temporal “drops” in your life that may be causing you to neglect the weightier matters of the gospel?
- b. What can you do to focus more on matters that are eternally important?

In Doctrine and Covenants 117:10, we read that the Lord called William Marks to continue serving as a Church leader when he arrived in Far West, Missouri. The Lord also said that if President Marks would be “faithful over a few things,” he would “be a ruler over many” (see also Matthew 25:23).

Read Doctrine and Covenants 117:11, looking for the rebuke the Lord gave to Newel K. Whitney. The Nicolaitans, mentioned in this verse, were members of an ancient religious sect. They said they were Christians but they strayed from the principles of the gospel to worldly practices. For example, their worship included committing sexual sins. (See Bible Dictionary, “Nicolaitans”; *Doctrine and Covenants Student Manual*, 2nd ed. [Church Educational System manual, 2001], 290.)

If Newel K. Whitney had decided to focus on property in Kirtland rather than gathering with the Saints, how might his actions be similar to the actions of the Nicolaitans? \_\_\_\_\_

\_\_\_\_\_

\_\_\_\_\_

Because of their concern about Church property in Ohio and because of persecution in Missouri, William Marks and Newel K. Whitney were not able to gather with the Saints in Far West. However, they followed the counsel of the Lord and remained faithful, and they later gathered with the Saints in Nauvoo, Illinois, where William Marks served as stake president and Newel K. Whitney served as a bishop.

## Doctrine and Covenants 117:12–16

*The Lord commissions Oliver Granger to represent the First Presidency in business dealings in Kirtland*

Think about Church callings and assignments you might receive. These callings and assignments might include serving in a quorum or class presidency, giving a talk in sacrament meeting, serving as a home teacher, fellowshipping someone, or serving as a full-time missionary. What kinds of sacrifices might these callings require?



Young men who hold the Aaronic Priesthood can serve as home teachers.

The Lord commanded a man named Oliver Granger to leave Far West, Missouri, and return to Kirtland, Ohio, to “contend earnestly for the redemption of the First Presidency of my Church” (D&C 117:13). This assignment included selling Church properties and settling Joseph Smith’s business affairs. This would require Oliver, who was nearly blind, to make sacrifices. Read Doctrine and Covenants 117:12–15, looking for the blessings the Lord said Oliver would receive as he fulfilled this assignment.



In verse 13, notice the Lord’s statement that “his sacrifice shall be more sacred unto me than his increase.” This indicates that the Lord cared more about Oliver’s sacrifice than the money Oliver might obtain as part of his assignment. From this verse, we learn the following principle: **The sacrifices we make in the service of the Lord are sacred to Him.** Mark the words in verse 13 that teach this principle.

 **3. Answer the following questions in your scripture study journal:**

- a. Why is it important to do everything you can to fulfill a Church assignment or calling?
- b. How do you feel when you consider that the sacrifices you make in the service of the Lord are sacred to Him?

Oliver Granger died in Kirtland on August 25, 1841. At the time, he was still acting as the First Presidency’s representative in their business affairs, and he had also been called to preside over the Church in Kirtland. Although he was not completely successful in settling the business affairs of the Church, he worked to preserve the Church’s integrity and good name. He was true to the Lord and the Prophet Joseph Smith.

In a letter of recommendation, Joseph Smith and the other members of the First Presidency described Oliver Granger as “a man of the most strict integrity and moral virtue; and in fine, . . . a man of God” (in *History of the Church*, 3:350). President Boyd K. Packer of the Quorum of the Twelve Apostles said:



“What did Oliver Granger do that his name should be held in sacred remembrance? Nothing much, really. It was not so much what he did as what he was. . . .

“The Lord did not expect Oliver to be perfect, perhaps not even to succeed. . . .

“We cannot always expect to succeed, but we should try the best we can” (“The Least of These,” *Ensign* or *Liahona*, Nov. 2004, 86).

## Doctrine and Covenants 118

*The Lord appoints new Apostles and calls all the Apostles to serve a mission*

On July 8, 1838, the Lord called new Apostles to replace those who had apostatized. The Lord also called the Twelve Apostles to preach the gospel.

Read Doctrine and Covenants 118:4–5, looking for where the Lord directed the Twelve to preach the gospel. The phrase “over the great waters” referred to traveling across the Atlantic Ocean to Great Britain. In Doctrine and Covenants 118:5, notice the place where they were to gather before leaving on their missions. Notice also the date the Lord said they should gather in that place.

In the months following this revelation, persecution increased in Missouri. Eventually the Saints were expelled from that state. These conditions made it dangerous for the Twelve to fulfill the Lord’s command to meet in Far West. Many Missourians openly boasted that they would prevent the fulfillment of the revelation. But the Twelve were determined to obey the Lord’s command.

On the morning of April 26, 1839, members of the Quorum of the Twelve Apostles gathered at the temple site. (Not all faithful members of the quorum could be there. Some had been imprisoned.) They recommenced laying the foundation of the temple (see D&C 115:11) by placing a large stone near the southeast corner of the lot. They ordained new Apostles to fill vacancies in the Quorum of the Twelve. Then they left, undetected by their enemies. (For a more complete account of this experience, see *Teachings of Presidents of the Church: Wilford Woodruff* [2004], 139–41.)



Cornerstones for a temple in Far West, Missouri, were laid in July 1838.



## Doctrine and Covenants 119–20

*The Lord reveals the law of tithing*



Doctrine and Covenants 119 and 120 contain two revelations on the law of tithing. In the revelation recorded in Doctrine and Covenants 120, the Lord directed that a council be organized to direct the use of the tithing funds of the Church. Today, each ward or branch submits the members' tithing funds to Church headquarters and this council, called the Council on the Disposition of Tithes. Local leaders do not determine how tithing funds are used.

Read Doctrine and Covenants 119:1–4. It may be helpful to know that in verse 4, the word *interest* means increase or income.



President Howard W. Hunter explained: "The law is simply stated as 'one-tenth of all their interest.' Interest means profit, compensation, increase. It is the wage of one employed, the profit from the operation of a business, the increase

of one who grows or produces, or the income to a person from any other source. The Lord said it is a standing law 'forever' as it has been in the past" (in Conference Report, Apr. 1964, 35).

As you read the following statements by Presidents of the Church, look for blessings you can receive when you pay tithing:



President Harold B. Lee referred to the Lord's promise to "open . . . the windows of heaven" to bless tithe payers (see Malachi 3:8–11): "The opening of the windows of heaven, of course, means revelations from God to him who is

willing thus to sacrifice" ("The Way to Eternal Life," *Ensign*, Nov. 1971, 16).



President Heber J. Grant spoke of the spiritual blessings that come to us when we pay tithing: "Prosperity comes to those who observe the law of tithing. When I say prosperity I am not thinking of it in terms of dollars and cents alone.

. . . But what I count as real prosperity, as the one thing of all others that is of great value to every man and woman living, is the growth in a knowledge of God, and in a testimony, and in the power to live the gospel and to inspire our families to do the same. That is prosperity of the truest kind" (*Teachings of Presidents of the Church: Heber J. Grant* [2002], 124).

President Grant also taught of one way we can be blessed financially when we pay tithing: "If we give in proportion to our means, if we pay our tithing, no matter how small the income, . . . God our Heavenly Father will magnify the remaining nine dollars out of ten, or the remaining forty-five cents out of every fifty and you will have sufficient wisdom to utilize it to advantage so that you will lose nothing in being honest" (*Teachings: Heber J. Grant*, 124–25).

### Evaluating Your Life

When you take time to honestly evaluate how well you are living a certain principle, you give the Holy Ghost the opportunity to help you realize what you are doing well and how you can improve. As you ponder the revelations recorded in Doctrine and Covenants 119 and 120, ask yourself how fully you are living the law of tithing.



**4.** Answer the following question in your scripture study journal: What blessings have you received because you have obeyed the law of tithing?



**5.** Write the following at the bottom of today's assignments in your scripture study journal:

*I have studied Doctrine and Covenants 117–20 and completed this lesson on (date).*

*Additional questions, thoughts, and insights I would like to share with my teacher:*

# Doctrine and Covenants 121:1–10; 122

## Introduction

Doctrine and Covenants 121–23 contain selected portions of a letter from the Prophet Joseph Smith to the Church, dated March 20, 1839. Joseph Smith dictated the letter while he and a few companions were imprisoned in Liberty Jail. In the letter, Joseph included some of his prayers for the Saints who were suffering because of the actions of their enemies. He also included answers he had received to those prayers. (See *History of the Church*, 3:289–305.) You will be studying Doctrine and Covenants 121–23 in the four daily lessons this week.

## Doctrine and Covenants 121:1–6

### *Joseph Smith prays for the suffering Saints*

Imagine that a friend is going through a difficult experience. The friend tells you that she does not understand why she is experiencing such afflictions and that she feels as though God has abandoned her. What would you tell your friend?

What would you do if you were the one experiencing the afflictions?

As you study the Prophet Joseph Smith’s prayers in Liberty Jail and the Lord’s counsel to Him, look for doctrines and principles that can help you faithfully endure trials and afflictions.

On October 31, 1838, George Hinkle, a member of the Church and a colonel in Missouri’s state militia,



betrayed Joseph Smith. Hinkle told Joseph that the people who had attacked the Saints in Far West, Missouri, wanted to meet for a peaceful interview to settle disagreements. When Joseph and other Church leaders arrived for the interview, the militia took them forcefully as prisoners of war. For the next month, Joseph Smith and his associates were abused and insulted as their enemies held them in several jails throughout the region and brought them before numerous judges.

While the Prophet Joseph Smith, Elder Parley P. Pratt, and other Church leaders were unjustly held in a jail in Richmond, Missouri, they heard the prison guards describe, in filthy language, horrid deeds of robbery, rape, and murder against Latter-day Saints. In his description of the experience, Elder Pratt wrote:



“In one of those tedious nights we had lain as if in sleep till the hour of midnight had passed, and our ears and hearts had been pained, while we had listened for hours to the obscene jests, the horrid oaths, the dreadful blasphemies and filthy language of our guards. . . .

“I had listened till I became so disgusted, shocked, horrified, and so filled with the spirit of indignant justice that I could scarcely refrain from rising upon my feet and rebuking the guards; but had said nothing to Joseph, . . . although I lay next to him and knew he was awake. On a sudden he arose to his feet, and spoke in a voice of thunder, or as the roaring lion, uttering, as near as I can recollect, the following words:

“‘SILENCE, ye fiends of the infernal pit. In the name of Jesus Christ I rebuke you, and command you to be still; I will not live another minute and hear such language. Cease such talk, or you or I die THIS INSTANT!’

“He ceased to speak. He stood erect in terrible majesty. Chained, and without a weapon; calm, unruffled and dignified as an angel, he looked upon the quailing guards, whose knees smote together, and who, shrinking into a corner, or crouching at his feet, begged his pardon, and remained quiet till a change of guards.

“I have seen the ministers of justice, clothed in magisterial robes, . . . while life was suspended on a breath, in the Courts of England; I have witnessed a Congress in solemn session to give laws to nations; I have tried to conceive of kings, of royal courts, of thrones and crowns; and of emperors assembled to decide the fate of kingdoms; but dignity and majesty have I seen but *once*, as it stood in chains, at midnight, in a dungeon in an obscure village of Missouri” (*Autobiography of Parley P. Pratt*, ed. Parley P. Pratt Jr. [1938], 210–11).



"Dignity and majesty . . . stood in chains."

While still awaiting trial based on false accusations, and without due process, Joseph Smith and other Church leaders were taken to a jail in Liberty, Missouri, on November 30. (See *History of the Church*, 3:188–89, 215.)



Liberty Jail, Missouri

During the next four months, the Prophet, his brother Hyrum, Alexander McRae, Lyman Wight, and Caleb Baldwin were held in the lower dungeon of Liberty Jail during a bitterly cold winter. Sidney Rigdon was also with them for a

time, but he was set free in early February. The floor of the dungeon was about 14 feet by 14 feet (4.3 meters by 4.3 meters). The ceiling was between 6 and 6.5 feet high (between 1.8 and 2 meters). Two small, barred windows offered very little light, and from outside these windows, people mocked and insulted the prisoners. The prisoners slept on dirty straw on the floor, and for some time Joseph did not have a blanket. The food was occasionally poisoned, and at other times it was so disgusting that they could only eat it out of desperate hunger. They were rarely allowed visitors and were deeply pained at hearing of the suffering of the Saints who were driven from Missouri in the middle of the winter.

The letter from which Doctrine and Covenants 121–23 was taken included some of Joseph Smith's prayers to the Lord. If you were in the Prophet's situation, what would you pray for?

Read Doctrine and Covenants 121:1–6, and notice what the Prophet prayed for, including the questions he asked. You may want to mark phrases that are meaningful to you. (As you read verses 1 and 4, it may be helpful to know that a pavilion is a building or another structure that provides covering.)

## Doctrine and Covenants 121:7–10; 122

### *The Lord comforts Joseph Smith*

The Lord's answer to Joseph Smith's prayer is found in Doctrine and Covenants 121:7–46 and 122:1–9. Read Doctrine and Covenants 121:7–9, looking for truths that would have helped Joseph and his companions during their time in Liberty Jail.



1. As you study Doctrine and Covenants 121:7–9, complete the following in your scripture study journal:

- Write at least two truths you find in these verses. Explain how these principles or doctrines might have helped Joseph and his companions.
- Answer the following questions: What do you think is the difference between enduring a trial and enduring a trial well? The Lord said that Joseph Smith's adversity and afflictions would "be but a small moment" (D&C 121:7). What do you think this means? How can this perspective help us endure our trials well?
- In two or three sentences, write about someone you know who is an example of enduring a trial well.



2. Think back to the situation described at the beginning of this lesson—a friend who is suffering and thinks that God has abandoned her. Write a letter of comfort to this friend, using the truths you identified in Doctrine and Covenants 121:7–9. Explain how these truths can help her. You might want to quote some or all of verse 9 in the letter.



Ponder the strength you receive from your knowledge that when we call upon the Lord during times of adversity and affliction, we can receive His peace, and that if we endure trials well in mortality, God will bless us now and in the eternities.

In Doctrine and Covenants 122, we read additional counsel and comfort that the Lord gave to Joseph Smith. Read Doctrine and Covenants 122:1–4, looking for blessings the Lord promised to Joseph. How do you



think these promises would have helped the Prophet during this difficult time?

Read Doctrine and Covenants 122:5–7, looking for a principle the Lord taught Joseph Smith about why we experience afflictions. You may want to mark words and phrases that are important to you.

What can we learn from these verses about one purpose of afflictions? Complete the following sentence: **Afflictions can give us \_\_\_\_\_ and be for our \_\_\_\_\_.**



Elder Joseph B. Wirthlin of the Quorum of the Twelve Apostles explained how afflictions can give us experience and be for our good.

“You may feel singled out when adversity enters your life. You shake your head and wonder, ‘Why me?’

“But the dial on the wheel of sorrow eventually points to each of us. At one time or another, everyone must experience sorrow. No one is exempt. . . .

“Learning to endure times of disappointment, suffering, and sorrow is part of our on-the-job training. These experiences while often difficult to bear at the time, are precisely the kinds of experiences that stretch our understanding, build our character, and increase our compassion for others” (“Come What May, and Love It,” *Ensign* or *Liahona*, Nov. 2008, 27).



Elder Orson F. Whitney of the Quorum of the Twelve Apostles also taught that afflictions can be for our good: “No pain that we suffer, no trial that we experience is wasted. It ministers to our education, to the development of such qualities as patience, faith, fortitude and humility. All that we suffer and all that we endure, especially when we endure it patiently, builds up our characters, purifies our hearts, expands our souls, and makes us more tender and charitable, more worthy to be called the children of God . . . and it is through sorrow and suffering, toil and tribulation, that we gain the education that we come here to acquire” (in Spencer W. Kimball, *Faith Precedes the Miracle* [1972], 98).



The Prophet Joseph Smith experienced many more afflictions after he suffered in Liberty Jail. President Brigham Young said: “Joseph could not have been perfected, though he had lived a thousand years, if he had received no persecution. If he had lived a thousand years, and led this people, and preached the Gospel without persecution, he would not have been perfected as well as he was at the age

of [thirty-eight] years” (*Teachings of Presidents of the Church: Brigham Young* [1997], 264).



**3.** In your scripture study journal, write about a difficult experience that has been for your good.

Have you ever heard people say that no one understands the trials they are experiencing? Read Doctrine and Covenants 122:8, looking for what the Lord might say in response to this comment. To increase your understanding of the phrase “descended below them all,” read 2 Nephi 9:20–21; Alma 7:11; and Doctrine and Covenants 88:5–6. You might consider writing the following doctrine next to Doctrine and Covenants 122:8: ***The Savior suffered the pains and afflictions of all people.***



**4.** Answer the following questions in your scripture study journal:

- How do you think this doctrine might have helped the Prophet Joseph Smith and his companions in Liberty Jail?
- How might this doctrine help you as you experience trials?

Elder Wirthlin taught:



“Because Jesus Christ suffered greatly, He understands our suffering. He understands our grief. We experience hard things so that we too may have increased compassion and understanding for others.

“Remember the sublime words of the Savior to the Prophet Joseph Smith when he suffered with his companions in the smothering darkness of Liberty Jail:

“‘My son, peace be unto thy soul; thine adversity and thine afflictions shall be but a small moment;

“‘And then, if thou endure it well, God shall exalt thee on high; thou shalt triumph over all thy foes.’ (D&C 121:7–8.)



“With that eternal perspective, Joseph took comfort from these words, and so can we” (“Come What May, and Love It,” 27).

Read Doctrine and Covenants 122:9, and think about how this verse relates to the life and ministry of the Prophet Joseph Smith.

 **5.** Answer the following question in your scripture study journal: How can the Lord’s words in Doctrine and Covenants 122:9 strengthen you during difficult experiences?

Soon after this letter was written, the Lord opened a way for Joseph Smith and his companions to reunite with the Saints in Illinois. God was with His servant Joseph Smith throughout Joseph’s life. Later, a year and a half before he was martyred, Joseph Smith declared: “God Almighty is my shield; and what can man do if God is my friend?” (in *History of the Church*, 5:259). If we remain faithful in our afflictions, God will also be with us to strengthen and support us forever.

 **6.** Write the following at the bottom of today’s assignments in your scripture journal:

*I have studied Doctrine and Covenants 121:1–10; 122:1–9 and completed this lesson on (date).*

*Additional questions, thoughts, and insights I would like share with my teacher:*

## UNIT 26: DAY 2

# Doctrine and Covenants 121:11–33

## Introduction

Doctrine and Covenants 121 contains portions of an inspired letter the Prophet Joseph Smith wrote to the Saints, dated March 20, 1839, from Liberty Jail. Doctrine and Covenants 121:11–33 contains the Savior’s description of the judgment that will come upon the wicked and His promise of revelation to the valiant.

## Doctrine and Covenants 121:11–25

*The Savior describes the judgments that would come upon those who persecute the Saints*

Imagine that one morning as you are leaving your home, you notice this statement posted outside on the door of your home: “The Mormons must be treated as enemies and *must be exterminated.*”

Would you be afraid to leave your home? Where would you turn for help? How would you feel if you found out the statement was influenced by some of your former friends?

Before the Prophet Joseph Smith was put in jail, some of his once loyal friends had turned against him. Two of these former friends, Thomas B. Marsh and Orson Hyde, had been members of the Quorum of the Twelve Apostles. Both of these men signed an affidavit (a sworn statement) falsely accusing Joseph Smith and other Church members of planning to drive their enemies out by burning and destroying their property. This affidavit influenced the governor of Missouri to issue a statement, known as the extermination order, declaring that all Mormons must be exterminated or driven from the state. The statement you imagined being posted on your door is a direct quote from that extermination order (see *History of the Church*, 3:175).

Remember that Doctrine and Covenants 121–23 are portions of an inspired letter the Prophet Joseph Smith wrote to the Saints in March 1839 while he was imprisoned in Liberty Jail. Read Doctrine and Covenants 121:11–17, looking for what the Prophet learned from the Lord concerning what would happen to those who had accused the Lord’s servants of transgression.

The phrase “their hope shall be blasted, and their prospects shall melt away” (D&C 121:11) indicates that those who fight against the Lord’s servants ultimately will not succeed in their designs.

Study Doctrine and Covenants 121:18–22, looking for additional consequences that would come to those who falsely accuse and fight against the servants of the Lord. (In verse 19, the phrase “severed from the ordinances of [the Lord’s] house” means to lose or be separated from the blessings associated with temple ordinances.)



1. Answer the following questions in your scripture study journal:

- a. In verses 13 and 17, what reasons did the Lord give for why some had accused His servants of sin?
- b. According to verses 19–22, what are the dangers of speaking falsely against God’s servants?

The false statements from apostate members of the Church and others, coupled with the governor’s extermination order, influenced mobs to increase their persecution of the Saints in Missouri.



Mobs destroyed Church members’ property in Missouri.

As you read the following account, mark examples of how the Saints were treated unjustly:

On October 30, 1838, just three days after the extermination order was issued, approximately 240 men approached a Mormon settlement at a place called Hawn’s Mill (or Haun’s Mill). The women and children fled into the woods, while the men sought protection in the blacksmith shop. One of the Saints’ leaders, David Evans, swung his hat and cried for peace. The sound of a hundred rifles answered him, most of them aimed at the blacksmith shop. The mobbers shot mercilessly at everyone in sight, including women, elderly men, and children. Amanda Smith seized her two little girls and ran with Mary Stedwell across the millpond on a walkway. Amanda recalled, “Yet though we were women, with tender children, in flight for our lives, the demons poured volley after volley to kill us” (in Andrew Jenson, “Amanda Smith,” *The Historical Record*, July 1886, 84).

Members of the mob entered the blacksmith shop and found and killed 10-year-old Sardius Smith, son of Amanda Smith, when he was hiding under the blacksmith’s bellows. The man later explained, “Nits [young lice] will make lice, and if he had lived he would have become a Mormon” (in Jenson, “Haun’s Mill Massacre,” *Historical Record*, Dec. 1888, 673; see also B. H. Roberts, *A Comprehensive History of the Church*, 1:482). Alma Smith, Sardius’s seven-year-old brother, witnessed the murder of his father and brother and was himself shot in the hip. He was not discovered by the mob and was later miraculously healed through prayer and faith. Although a few men along with women and children escaped across the river into the hills, at least 17 people were killed, and about 13 were wounded. (See *Church History in the Fulness of Times Student Manual*, 2nd ed. [Church Educational System manual, 2003], 201, 203–4; see also *History of the Church*, 3:183–86.)

No one in the violent mob was brought to justice for their crimes in the courts of Missouri or by federal authorities.

What feelings might you have had if you had experienced these cruelties? How might you have felt when you learned that your attackers would not be held accountable for their actions?

Read Doctrine and Covenants 121:23–25, looking for phrases indicating that God would hold the Saints’ enemies accountable for their actions. (We do not know when these judgments will come upon the enemies of the Saints. Some consequences may not come until the next life.)

Complete the following statements of truth based on what you learned from verses 24–25.

- **The Lord \_\_\_\_\_ and \_\_\_\_\_ all our works.**
- **Those who fight against the Lord and His people will receive \_\_\_\_\_ at His appointed time.**



2. Think of times when you have seen people do wrong and seem to avoid the consequences. In your scripture study journal, answer the following question: How might the principles you identified in Doctrine and Covenants 121:24–25 relate to situations today when people appear to escape the consequences for their wrongdoing?

## Doctrine and Covenants 121:26–33

*God promises to reveal eternal truths through the Holy Ghost*



Lower level of the Liberty Jail

Read Doctrine and Covenants 121:26, looking for a truth the Prophet Joseph Smith recorded while he was imprisoned in Liberty Jail.

Use what you learn in verse 26 to complete the following statement: **God will**

\_\_\_\_\_ **through the**  
\_\_\_\_\_.



As you consider how this truth can relate to you when you experience difficulties, ponder the following statement by Elder Jeffrey R. Holland of the Quorum of the Twelve Apostles: “You can have sacred, revelatory, profoundly instructive

experience with the Lord *in the most miserable experiences of your life*—in the worst settings, while enduring the most painful injustices, when facing the most insurmountable odds and opposition you have ever faced” (“Lessons from Liberty Jail” [Brigham Young University fireside, Sept. 7, 2008], 4; speeches.byu.edu).

The following account by Lucy Mack Smith provides an example of how God can reveal knowledge to us through the Holy Ghost. As you read this account, notice how the knowledge she received through the Holy Ghost comforted her about the her sons’ imprisonment in Liberty Jail after Joseph and Hyrum were taken as prisoners and threatened with death.



“For some time our house was filled with mourning, lamentation, and woe; but, in the midst of my grief, I found consolation that surpassed all earthly comfort. I was filled with the Spirit of God, and received the following by the gift of prophecy: ‘Let your heart be comforted concerning your children, they

shall not be harmed by their enemies. . . .’ This relieved my mind, and I was prepared to comfort my children. I told them what had been revealed to me, which greatly consoled them” (*History of Joseph Smith by His Mother*, ed. Preston Nibley [1958], 291).



**3.** Answer one or both of the following questions in your scripture study journal:

- How can receiving knowledge through the Holy Ghost help you when you experience difficulties?
- When have you received knowledge through the Holy Ghost that has helped you through a difficult time?

In Doctrine and Covenants 121:26–33, the Lord promised to reveal knowledge that had “not been revealed since the world was” (D&C 121:26) and to bestow glorious blessings upon all who “endured valiantly for the gospel of Jesus Christ” (D&C 121:29).

In Doctrine and Covenants 121:33, the Prophet Joseph Smith used an analogy to help the Saints understand that the Lord was more powerful than those who were persecuting the Saints and attempting to stop the work of God.

Read verse 33, looking for the comparison Joseph Smith gave to illustrate the power of God. The Missouri River is a large and powerful river that many of the early Saints had lived near and were familiar with.



The Missouri River

How effective would a person be in stopping the course of a large and powerful river by using only an arm? What do you think the Lord was teaching the Prophet about the revelation He was going to send?

One doctrine we learn from Doctrine and Covenants 121:33 is that **nothing can stop the Lord’s work from going forward.**



**4.** Answer the following question in your scripture study journal: How do you feel knowing that the Lord’s work will continue regardless of opposition?



5. Write the following at the bottom of today's assignments in your scripture study journal:

*I have studied Doctrine and Covenants 121:11–33 and completed this lesson on (date).*

*Additional questions, thoughts, and insights I would like share with my teacher:*

## UNIT 26: DAY 3

# Doctrine and Covenants 121:34–46

### Introduction

Doctrine and Covenants 121:34–46 is a portion of the Prophet Joseph Smith's inspired letter from Liberty Jail. In this portion of the letter, the Prophet teaches principles about the power and authority of the priesthood. He explains why many are called but few are chosen and how priesthood holders can draw upon the powers of heaven to serve others.

### Doctrine and Covenants 121:34–40

*Joseph Smith teaches that the rights of the priesthood are connected with the powers of heaven*

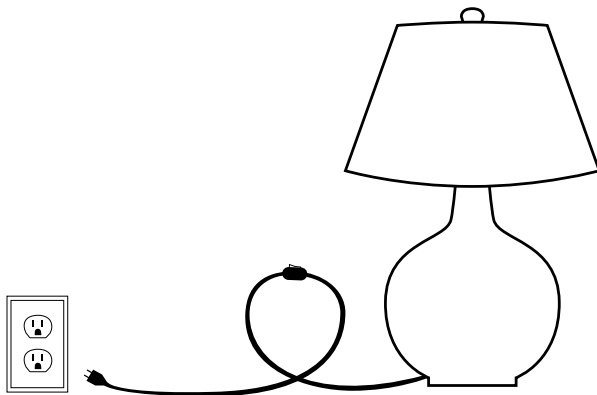

In what ways do you think exercising the priesthood can be compared to turning on a lamp?

Write *Priesthood holder* next to the lamp in the illustration. In this lesson, light from the lamp

represents blessings people can receive from God through the service of a priesthood holder.

In your study of Doctrine and Covenants 121 today, consider how a priesthood holder's righteousness affects his ability to help other people receive the blessings of the priesthood. Although these verses are directed to priesthood holders, they contain principles that apply to all Church members.

Read Doctrine and Covenants 121:34, giving attention to the question in this verse. You may want to mark the question.

To increase your understanding of what it means for a priesthood holder to be "called" and "chosen," read the following statement by President James E. Faust of the First Presidency to priesthood holders: "We are called when hands are laid upon our heads and we are given the priesthood, but we are not chosen until we have demonstrated to God our righteousness, our faithfulness, and our commitment" ("Called and Chosen," *Ensign* or *Liahona*, Nov. 2005, 55).

In Doctrine and Covenants 121:35–39, we learn why some priesthood holders are not chosen. Read Doctrine and Covenants 121:35–36, looking for a lesson every priesthood holder should learn. You may want to mark what you find.

Write *Powers of heaven* next to the electrical outlet in the illustration. In this analogy, electricity represents the powers of heaven.

Notice the phrase "rights of the priesthood" in verse 36. A man receives the right to exercise the priesthood when priesthood authority is conferred upon him by the laying on of hands. The right to act with this authority depends on a man's worthiness. On the illustration, label the electrical cord *Priesthood authority*.

Imagine that you plug the cord of a lamp into the power source, but the lamp does not light up. You examine the lamp and find that the light switch is not in the "on" position. Next to the light switch (on the cord in the illustration), write *Principles of righteousness*.



1. Complete the following in your scripture study journal:

- In this analogy, how is following the "principles of righteousness" like turning on the switch of a lamp?
- Based on what you learn in Doctrine and Covenants 121:36, complete the following statement: *Priesthood holders can draw upon the powers of heaven only if they . . .*



Read Doctrine and Covenants 121:37–38, looking for what happens to a priesthood holder’s ability to draw on the powers of heaven if he does not live righteously. You may want to mark what you find. (In verse 38, the phrase “kick against the pricks” refers to an animal resisting a sharp stick used to guide it toward a desired destination. For us, this phrase refers to resisting direction from the Lord and His servants.)

Review verses 35 and 37, looking for unrighteous attitudes and actions that weaken a priesthood holder’s connection with the powers of heaven. You may want to mark your findings. Then read the following examples. Look for attitudes and actions that are mentioned in verses 35 and 37. In the blanks provided, list those attitudes and actions.

- To fit in with some of his popular peers, a priesthood holder joins them in making fun of a classmate at school. \_\_\_\_\_
- A teachers quorum president loves sports, and he refuses to participate in the planning of any quorum activity that does not involve soccer or basketball. Whenever the quorum participates in an activity or gives service, he demands that the other young men do as he says because he is the quorum president. \_\_\_\_\_

In connection with the warning about priesthood holders who “undertake to cover [their] sins” (D&C 121:37), consider the account of King David in 2 Samuel 11. After David committed the sin of adultery with Bathsheba and she became pregnant, he tried to cover up his sins, ultimately arranging the death of her husband, Uriah. Can you think of other situations in which people try to cover their sins?

What are the dangers of setting your heart on the things of the world and aspiring to the honors of men?

 **2.** Answer the following question in your scripture study journal: Why do you think the attitudes and actions listed in Doctrine and Covenants 121:35, 37 prevent priesthood holders from drawing on the powers of heaven?

Read Doctrine and Covenants 121:39–40, looking for why some people begin to exercise unrighteous dominion (control over others).

 **3.** Based on what you have learned from Doctrine and Covenants 121:34–40, in your scripture study journal, summarize the reasons why “many are called, but few are chosen” (D&C 121:40).

## Doctrine and Covenants 121:41–46

*Joseph Smith teaches how priesthood holders should conduct themselves*

After teaching about attitudes and actions that weaken the connection between priesthood holders and the powers of heaven, the Prophet Joseph Smith taught about attitudes and actions that strengthen that connection. Read Doctrine and Covenants 121:41–45, looking for attitudes and actions that help priesthood holders draw on the powers of heaven. Consider marking these attitudes and actions as you find them. As you read, it may be helpful to know that in verse 41, the word *only* means “except,” and to act with love unfeigned and without hypocrisy or guile is to love people sincerely and genuinely and to have righteous motivations.

 **4.** In your scripture study journal, write about why the qualities listed in Doctrine and Covenants 121:41–45 are important for priesthood holders. Also answer the following question: Why are these qualities important for all Latter-day Saints to possess? Choose one principle of righteousness mentioned in these verses, and set a goal to live that principle better.

In verse 43, the word *reproving* refers to telling someone that he or she is doing something wrong, usually in a gentle or kind manner. The word *betimes* means “early” or “in a timely manner.” The word *sharpness* could refer to the need to express ourselves clearly. Why do you think it is important for a priesthood leader to reprove clearly, at the right time, and according to the guidance of the Holy Ghost? Why do you think it is important to show increased love after reprovving someone? When have you benefited from such correction?

 **5.** Answer the following questions in your scripture study journal:

- a. Why do you think it is important for priesthood holders to be gentle and kind in the way they interact with others?
- b. What do you think it means to “let virtue garnish [your] thoughts unceasingly” (D&C 121:45)? What are some things you can do to keep your thoughts virtuous?
- c. How can the principles in Doctrine and Covenants 121:41–45 help all of us as we interact with each other?



Living these principles of righteousness helps us become more like Heavenly Father and Jesus Christ and better able to bless the lives of others.

Read Doctrine and Covenants 121:45–46, looking for the blessings that come to priesthood holders who draw on the powers of heaven through righteous living. Consider marking what you find.

As you read these verses, it may be helpful to know that a scepter is a staff carried by a king or queen. It is a symbol of authority and power.

As you ponder the command to “let virtue garnish [your] thoughts unceasingly” (D&C 121:45), it may be helpful to know that when this revelation was given, one meaning of the word *garnish* was “to adorn,” which suggests making a close connection. Another meaning was “to fit with fetters”—in other words, “to restrain.” (See Noah Webster, *An American Dictionary of the English Language*, facsimile of the first edition [1828; repr., 1967], “garnish.”) From these definitions, we learn that we should allow virtue to accompany and control our thoughts.

 **6.** In your scripture study journal, write about a priesthood holder you know who lives in a way that helps him draw on the powers of heaven. How have you been blessed through his service?

## Scripture Mastery—Doctrine and Covenants 121:36, 41–42

 **7.** Spend some time repeating Doctrine and Covenants 121:36 aloud until you can recite it from memory. Then recite it to a family member. To help you apply the principles in verses 41–42, make a list of the attributes described in these verses. Place the list where you can read it.

 **8.** Write the following at the bottom of today’s assignments in your scripture study journal:

*I have studied Doctrine and Covenants 121:34–46 and completed this lesson on (date).*

*Additional questions, thoughts, and insights I would like to share with my teacher:*

### UNIT 26: DAY 4

# Doctrine and Covenants 123; The Establishment of Nauvoo

## Introduction

While the Prophet Joseph Smith was imprisoned in Liberty Jail in Liberty, Missouri, from December 1838 to April 1839, he wrote letters of comfort and counsel to the Saints. Doctrine and Covenants 123 is an excerpt from a letter dated March 20, 1839, that he wrote to the Saints. In this excerpt, Joseph gave counsel to the Saints who had been driven from Missouri. After Joseph Smith was allowed to escape imprisonment, he rejoined the Saints and worked with them to establish the city of Nauvoo, Illinois.

## Doctrine and Covenants 123:1–6

*Joseph Smith counsels the Saints to collect and publish accounts of their persecutions and sufferings*

In March 1839 the Saints were suffering harsh persecutions in Missouri. The Prophet Joseph Smith and some of the other Church leaders were being held in the jail at Liberty, Missouri, and the Saints had been driven from the state of Missouri during the harsh winter months because of Governor Lilburn W. Boggs’s extermination order.

Read the following statement, which describes some of the wrongs done to the Saints: “This may certify that I, Delia Reed, moved to Missouri in the year 1836. My husband died soon after we arrived and left me with seven small children. I then moved to Caldwell County, made an improvement, [and] continued on said farm until the autumn of 1838. When the troubles came on between the inhabitants and the Mormons, I, with the rest of our society, was obliged to leave the state. . . . I was obliged to sacrifice the most of my property [and] my family [became] scattered, and I had to gain a daily pittance among strangers” (Delia Reed, in *Mormon Redress Petitions: Documents of the 1833–1838 Missouri Conflict*, ed. Clark V. Johnson [1992], 523; punctuation, capitalization, and spelling standardized).



A portion of the affidavit listing the sufferings and damages the Prophet Joseph Smith sustained in Missouri

Sister Reed gave this official statement to a judicial official. Ponder why she might have given this statement.

Read Doctrine and Covenants 123:1–5, looking for what the Prophet Joseph Smith counseled the persecuted Saints to do. It may be helpful to know that in verse 5 the phrase “concatenation of diabolical rascality” refers to a collection of wicked lies, and the phrase “nefarious and murderous impositions” refers to evil and violent deeds.

Read Doctrine and Covenants 123:6, looking for reasons why the Saints were told to collect accounts of their persecutions and sufferings. (As you read, it may help to know that the phrase “enjoined on us” means “required of us.”)

Many of the Saints were obedient to the Prophet’s counsel and collected numerous accounts of their persecutions, which included the destruction and loss of their homes, livestock, and other properties; physical abuses; and even the loss of lives. Why do you think it was important for the Saints to gather these

accounts and submit them to the heads of government rather than just waiting or hoping for God to solve their problems for them? One truth we can learn from Doctrine and Covenants 123:6 is that **the Lord will fulfill His promises after we have done our part**. Ponder why you think the Lord expects us to do our part before He will fulfill His promises.



1. Answer the following question in your scripture study journal: When have you seen this truth fulfilled in your own life or in the life of someone you know?

## Doctrine and Covenants 123:7–17

*Joseph Smith counsels the Saints to help those who are deceived by falsehoods*

Imagine you have been given an assignment to write a report about the Church for one of your school classes. As part of the requirement, you need to include at least three sources. Think about how you would answer the following questions:

- What sources might you use for your paper?
- Why does it matter what sources you use to write about the Church?
- How do you know which sources accurately describe the Church?

Read Doctrine and Covenants 123:7–10. When the Prophet Joseph Smith wrote this letter, many lies were being spread about the Church. The Saints were told that it was their “imperative duty” (D&C 123:7, 9) to collect and publish the accounts of their persecutions and sufferings in response to these lies.

Read Doctrine and Covenants 123:11–12, looking for additional reasons why the Saints were directed to collect and publish these accounts.



2. Answer the following questions in your scripture study journal:

- According to Doctrine and Covenants 123:12, how are many of the pure in heart blinded from seeing the truth?
- How might publishing the truth about the Saints’ persecutions and sufferings at this time have helped others find the truth of the gospel?
- According to verse 12, why are many people on the earth kept from the truth? Answer this question by completing the following truth: **There are many who are kept from the truth because . . .**

There are still many people today “who are blinded by the subtle craftiness of men” and who are kept from the truth only because they do not know where to find it (D&C 123:12).



As you read the following statement by Elder M. Russell Ballard of the Quorum of the Twelve Apostles, underline what he said keeps people from knowing the truth about the Church in our day: “Far too many people have a poor understanding of the Church because most of the information they hear about us is from news media reports that are often driven by controversies. Too much attention to controversy has a negative impact on peoples’ perceptions of what The Church of Jesus Christ of Latter-day Saints really is” (“Sharing the Gospel Using the Internet,” *Ensign* or *Liahona*, July 2008, 62).

Similar to the Saints in 1839, we are directed to help others have a correct understanding of the Church—its members, leaders, beliefs, history, teachings, and practices.

 **3.** In your scripture study journal, list what you can do to help others obtain a correct understanding of the Church and to help them know where they can find the truth.

As you read the following statement from Elder Ballard, look for one way he said we can help others obtain a correct understanding of the Church:

“There are conversations going on about the Church constantly. Those conversations will continue whether or not we choose to participate in them. But we cannot stand on the sidelines while others, including our critics, attempt to define what the Church teaches. While some conversations have audiences in the thousands or even millions, most are much, much smaller. But all conversations have an impact on those who participate in them. Perceptions of the Church are established one conversation at a time. . . .

“Now, may I ask that you join the conversation by participating on the Internet to share the gospel and to explain in simple and clear terms the message of the Restoration. . . . *This, of course, requires that you understand the basic principles of the gospel.* It is essential that you are able to offer a *clear and correct* witness of gospel truths” (“Sharing the Gospel Using the Internet,” 61–62).

 **4.** Complete the following assignments in your scripture study journal:

- Write about a time when you or someone you know helped others understand more about the Church.
- Select one of the ways you listed in assignment 3, and write how you will do that to help others learn and find truths about the Church and the gospel.

Read Doctrine and Covenants 123:13–16, looking for what the Saints were told about their efforts to present an accurate account of their experiences to others. According to verse 15, why were they told not to consider their efforts as “small things”?

One principle we can learn from Doctrine and Covenants 123:15 is that **our decisions to obey the seemingly small commandments of the Lord can have great influence on our lives in the future.**



According to Doctrine and Covenants 123:16, how can such a small thing like a helm (the steering wheel that controls the rudder) affect even a very large ship? (In this verse the phrase “being kept workways with the wind and the waves” refers to being able to turn the ship so that it maintains its balance and does not capsize during a storm.)

 **5.** Answer the following questions in your scripture study journal:

- How are our small decisions like the helm of a ship?
- How can these decisions help you maintain your balance during the storms of life?
- What small decisions are you making in your life now that could have a big impact on your future?

Read Doctrine and Covenants 123:17, looking for how this verse relates to the principle identified from verse 6: **The Lord will fulfill His promises to help us after we have done our part.**

Based on what the Prophet Joseph Smith wrote, we learn that **if we do all things that lie within our power to be obedient to the Lord’s commands, then we can have the assurance that God will use His power to help us according to His will and timing.**





6. Answer the following questions in your scripture study journal:

- Why do you think we need to “do all things that lie in our power” (D&C 123:17) before we can have the assurance that God will help us?
- Why do you think it is important to *cheerfully* do all things that lie in our power?

You can be confident that when you have done everything you can to obediently follow God’s commands, He will fulfill His promises.

## The Establishment of Nauvoo

Following their expulsion from Missouri, the Saints found refuge in Quincy, Illinois, and in other small communities in Illinois and Iowa. Locate Quincy on Church history map 5, “The Missouri, Illinois, and Iowa Area of the USA,” in your scriptures.

In April 1839, prison guards at the jail in Liberty, Missouri, allowed Joseph Smith to escape, and he joined his family in Quincy, Illinois. Under the Prophet’s direction, the Church purchased land on both sides of the Mississippi River north of Quincy. The west side of the river was part of Iowa Territory, and the east side was part of the state of Illinois. The Saints established the new headquarters of the Church on the Illinois side at a place called Commerce, which they renamed Nauvoo. *Nauvoo* is a Hebrew word that means “beautiful.”



While the Saints maintained headquarters in Nauvoo, the Prophet Joseph Smith was inspired to organize the Relief Society; the Lord revealed the ordinances of baptism for the dead, the temple endowment, and the marriage sealing; and missionary work was expanded throughout the world.



7. Ask someone who is a member of Relief Society (such as a family member or friend) to tell you about some ways Relief Society has given her opportunities to participate in the Lord’s work and has blessed her life. Write down what you learn from her in your scripture study journal, and be prepared to share what you have written with other home-study students.



8. Write the following at the bottom of today’s assignments in your scripture study journal:

*I have studied Doctrine and Covenants 123 and “The Establishment of Nauvoo” and completed this lesson on (date).*

*Additional questions, thoughts, and insights I would like to share with my teacher:*

## UNIT 27: DAY 1

# Doctrine and Covenants 124:1–83

## Introduction

During the winter of 1838–39, the Saints fled Missouri and settled in Illinois on the Mississippi River. There the Saints began to build up a city in the area of a small settlement called Commerce. After the persecutions and hardships they had experienced, the Saints now had a place where they could gather and build up a city in peace. They developed their community and renamed it Nauvoo. When the Prophet Joseph Smith received the revelation recorded in Doctrine and Covenants 124 on January 19, 1841, the Saints had been in Nauvoo, Illinois, for nearly two years. In this revelation the Lord commanded the Saints to build a temple and explained the blessings that would be available to them if they would be diligent in building it.

## Doctrine and Covenants 124:1–41, 56–83

*The Lord commands the Saints to build a temple and a house for visitors in Nauvoo*

What is something you have accomplished that required a significant amount of time, effort, or sacrifice on your part? Why was it worth the time, effort, or sacrifice it required?

The Lord began the revelation in Doctrine and Covenants 124 by commanding that a proclamation to the rulers of the earth be written about the restoration



Temple baptismal font

of the gospel (see D&C 124:1–14). In fulfillment of this command, the Quorum of the Twelve Apostles published a proclamation on April 6, 1845, which began:

“Know ye:—

“That the kingdom of God has come: as has been predicted by ancient prophets, and prayed for in all ages; even that kingdom which shall fill the whole earth, and shall stand forever” (in James R. Clark, comp., *Messages of the First Presidency of The Church of Jesus Christ of Latter-day Saints*, 6 vols. [1965–75], 1:253).

One hundred thirty years later, President Ezra Taft Benson, then serving as President of the Quorum of the Twelve Apostles, delivered a general conference address in which he reaffirmed the message of that proclamation (see “A Message to the World,” *Ensign*, Nov. 1975, 33–34).

In addition to commanding that a proclamation be written, the Lord gave a commandment to the Saints that would require great sacrifice on their part. Read Doctrine and Covenants 124:25–27, looking for what the Lord commanded the Saints in Nauvoo to do.

What did the Lord want the Saints to use to build the temple?

By the time the Saints relocated to Nauvoo, Illinois, many had lost almost all of their property and possessions. Ponder how obeying the commandment to build another temple might have required faith and sacrifice from the Saints.

Read Doctrine and Covenants 124:28, looking for why the Lord said the Saints needed to build a temple. Mark what you find in your scriptures.



President Joseph Fielding Smith taught the following about “the fulness of the priesthood”: “Every man who is faithful and will receive these ordinances and blessings obtains a fulness of the priesthood, and the Lord has said that ‘he makes them equal in power, and in might, and in dominion.’ [D&C 76:95; see also D&C 88:107.] . . . The Lord has made it possible for every man in this Church, through his obedience, to receive the fulness of the priesthood through the ordinances of the temple of the Lord. This cannot be received anywhere else” (*Doctrines of Salvation*, comp. Bruce R. McConkie, 3 vols. [1954–56], 3:132–33).

All members of the Church—men and women—can receive the fulness of the blessings of the priesthood by receiving all of the ordinances of the temple. Through these ordinances we can gain access to all of the blessings Heavenly Father desires to give His children. The restoration of temple ordinances and covenants began in the Kirtland Temple, but it was not completed there. Building a temple in Nauvoo would allow the restoration of temple ordinances and covenants to continue (see D&C 124:28, 40–41).



1. Read the first two paragraphs under the topic “Ordinances” in the Guide to the Scriptures ([scriptures.lds.org](https://www.lds.org/scriptures)) or *True to the Faith: A Gospel Reference* ([2004], 109–10). Then answer the following question in your scripture study journal: What is an ordinance?

Some ordinances are essential to exaltation, and many of these saving ordinances can only be performed in temples. Read Doctrine and Covenants 124:29, looking for one of these essential temple ordinances that the Lord indicated needed to be restored.

On August 15, 1840, the Prophet Joseph Smith first taught that the Saints could perform saving ordinances like baptism on behalf of their deceased friends and family members who had not had the opportunity to receive the gospel (see *Teachings of Presidents of the Church: Joseph Smith* [2007], 403; see also 1 Corinthians 15:29). After this announcement, many baptisms for the dead were performed in the Mississippi River or in nearby streams.

### Basic Doctrines

As you study the scriptures daily and master key scripture passages, you will come to understand basic doctrines of the gospel. For instance, in this part of the lesson, look for aspects of the doctrine of ordinances that relate to what the Lord taught in Doctrine and Covenants 124.

Read Doctrine and Covenants 124:30–34, and look for the Lord’s direction concerning where the ordinance of baptism for the dead needs to be performed in order to be acceptable to Him.

Even though the Lord said that the ordinance of baptism for the dead needed to be performed in the temple, why did He allow the Saints to perform baptisms outside of the temple temporarily?



After Joseph Smith received the revelation in Doctrine and Covenants 124, work on the temple in Nauvoo progressed quickly. On October 3, 1841, after the basement of the temple was excavated, Joseph Smith told the Saints, “There shall be no more baptisms for the dead, until the ordinance can be attended to in the Lord’s House. . . . For thus saith the Lord!” (*Teachings of Joseph Smith*, 469). On November 21, 1841, after a temporary baptismal font had been built and dedicated in the basement of the Nauvoo Temple, baptisms for the dead resumed. (See *Church History in the Fulness of Times Student Manual*, 2nd ed. [Church Educational System manual, 2003], 251–52; see also *Teachings of Presidents of the Church: Joseph Smith*, 469–70.)



Doctrine and Covenants 124 teaches the following truth: **The temple is the only place where we can obtain the fulness of the priesthood ordinances for the redemption of the living and the dead.**



2. In your scripture study journal, write how you think this truth might have motivated the Saints to make the necessary sacrifices to build a temple in Nauvoo.



Mark the words or phrases that stand out to you in the following teaching of President Thomas S. Monson on the importance of this truth about the temple: “Those who understand the eternal blessings which come from the temple know that no sacrifice is too great, no price too heavy, no struggle too difficult in order to receive those blessings. There are never too many miles to travel, too many obstacles to overcome, or too much discomfort to endure. They understand that the saving ordinances received in the temple that permit us to someday return to our Heavenly Father in an eternal family relationship and to be endowed with blessings and power from on high are worth every sacrifice and every effort” (“The Holy Temple—a Beacon to the World,” *Ensign* or *Liahona*, May 2011, 92).



3. In your scripture study journal, write a few sentences describing why receiving the ordinances of the temple is important to you.

Ponder what you are doing in your life to prepare to worthily enter the temple and receive the fulness of the priesthood ordinances for yourself. Write in a personal journal or on a piece of paper what you feel you must do now to qualify to receive the ordinances of the temple.

Read Doctrine and Covenants 124:38–41, looking for why the Lord commanded Moses to build a tabernacle in the wilderness and instructed His people to build a temple in the land of promise.



Notice how long, according to these verses, the saving ordinances of the temple have been in existence.

 **4.** Imagine you have a friend who asks you the following questions, and then answer them in your scripture study journal:

- a. Why does the Church build temples?
- b. Why is the temple important to you?

In Doctrine and Covenants 124:22–24, 56–83, the Lord also instructed the Saints to build another structure called the Nauvoo House, where those visiting Nauvoo could stay.



This building was constructed on part of the foundation of the unfinished Nauvoo House site.

## Doctrine and Covenants 124:42–55

*The Lord explains what will happen if the Saints obey the commandment to build a temple*

Read Doctrine and Covenants 124:42–45, looking for what the Lord said would happen if the Saints would build the temple in Nauvoo, Illinois, and hearken to His voice and the voice of His servants.

In Doctrine and Covenants 124:46–54, the Lord explained what would happen if the Saints built the temple but then did not hearken to His voice or the voice of His servants. He also explained that He would accept the Saints' efforts to accomplish the Lord's work (including building temples) even if they were prevented from doing so because of the persecution they faced.

Read Doctrine and Covenants 124:55, looking for what the Lord declared the Saints would prove to Him by obeying His commandment to build the Nauvoo Temple.

According to verse 55, what do we prove to the Lord when we obey His commandments?

You may want to write the following principle in your scriptures next to verse 55: **By obeying the Lord's commandments, we prove our faithfulness.**

 **5.** Ponder times in your life when you have obeyed a commandment out of a desire to be loyal and faithful to Heavenly Father and the Savior. In your scripture study journal, write about one of these experiences and your feelings about showing the Lord your loyalty and faithfulness to Him.

According to Doctrine and Covenants 124:55, what additional blessings did the Lord promise the Saints if they would build a temple in Nauvoo? \_\_\_\_\_

 **6.** The blessings of honor, immortality, and eternal life promised in verse 55 are eternal in nature. In your scripture study journal, write why you think it is important to understand that some of the blessings we receive for our faithfulness to the Lord may not be immediate.

Challenge yourself to prove your faithfulness to God by faithfully obeying His commandments.

 **7.** Write the following at the bottom of today's assignments in your scripture study journal:

*I have studied Doctrine and Covenants 124:1–83 and completed this lesson on (date).*

*Additional questions, thoughts, and insights I would like to share with my teacher:*

## UNIT 27: DAY 2

# Doctrine and Covenants 124:84–145; 125–26

### Introduction

Doctrine and Covenants 124:84–145, received on January 19, 1841, contains the Lord's counsel to individual Church members. He also named those who were to serve in different priesthood leadership positions. In March 1841, the Prophet Joseph Smith received the revelation contained in Doctrine and Covenants 125, in which the Lord revealed His will concerning the gathering of the Saints in Iowa Territory. On July 9, 1841, the Prophet received the revelation contained in Doctrine and Covenants 126, in which the Lord told Brigham Young that he would no longer be required to leave his family to serve missions.



## Doctrine and Covenants 124:84–122

### *The Lord gives counsel to specific individuals*

Think about a time when you received counsel from someone who wanted to help you. Did you follow that counsel? Why or why not?



In Doctrine and Covenants 124:84–118, the Lord gave individual counsel to certain members of the Church that, if followed, promised great blessings. Read the following passages, looking for a similarity in the counsel given to these individuals. (It may be helpful to know that *counsel* refers to guidance, direction, or instruction. You may want to mark the counsel that is similar.)

- Verses 89–90 (William Law)
- Verses 94–96 (Hyrum Smith)
- Verses 111–14 (Amos Davies)
- Verses 115–18 (Robert Foster)

Review the verses you read, looking for the blessings the Lord promised if these men followed the counsel He gave them. In the space provided, list the blessings the Lord promised them: \_\_\_\_\_

One principle we learn from these verses that applies to all of God’s children is that **if we hearken to the counsel of the prophets, it will be well with us.**



1. Answer the following questions in your scripture study journal:

- a. What specific counsel has the President of the Church given in recent years?
- b. When have you been blessed by hearkening to the counsel of the prophets?

Read Doctrine and Covenants 124:84, looking for what the Lord said a Church member named Almon Babbitt had been doing instead of following the counsel of the Presidency of the Church. It may be helpful to know that “a golden calf” refers to the idol or false god that Aaron made for the children of Israel while the prophet Moses was on Mount Sinai (see Exodus 32). It is a symbol of worldly things that can distract and prevent us from receiving spiritual blessings.

According to verse 84, Almon Babbitt’s “golden calf” was that he aspired to establish his own counsel rather than the counsel of the First Presidency.

Read President Spencer W. Kimball’s warning about the many false gods that people worship today, and consider how these modern-day idols might replace following the counsel of living prophets:



“Modern idols or false gods can take such forms as clothes, homes, businesses, machines, automobiles, pleasure boats, and numerous other material deflectors from the path to godhood. What difference does it make that the item

concerned is not shaped like an idol? . . .

“Intangible things make just as ready gods. Degrees and letters and titles can become idols. . . . The [college] degree, and the wealth and the security which come through it, appear so desirable that [serving a] mission takes second place. Some neglect Church service through their college years, feeling to give preference to the secular training and ignoring the spiritual covenants they have made. . . .

“Many worship the hunt, the fishing trip, the vacation, the weekend picnics and outings. Others have as their idols the games of sport, baseball, football, the bullfight, or golf. These pursuits more often than not interfere with the worship of the Lord and with giving service to the building up of the kingdom of God. To the participants this emphasis may not seem serious, yet it indicates where their allegiance and loyalty are.

“Still another image men worship is that of power and prestige. Many will trample underfoot the spiritual and often the ethical values in their climb to success. These gods of power, wealth, and influence are most demanding and are quite as real as the golden calves of the children of Israel in the wilderness” (*The Miracle of Forgiveness* [1969], 40–42).



2. Answer the following question in your scripture study journal: What are some ways people might put their own counsel ahead of the counsel the Lord gives us today through His prophets?



Remember, you can be confident in following the counsel and instructions of the prophets because they speak the words of the Lord (see D&C 1:38).

Doctrine and Covenants 124:119–22 contains instructions to the Church regarding the construction of the Nauvoo House, which was to be a Church-owned hotel.

### Doctrine and Covenants 124:123–45

*The Lord names those who are to serve in various priesthood leadership positions*

List some priesthood leadership positions in the Church: \_\_\_\_\_

In Doctrine and Covenants 124:123–45, the Lord named specific individuals to serve in various priesthood leadership positions. Read verses 123–42, looking for the priesthood leadership positions the Lord mentioned. Add any that you did not have in your list.

Read Doctrine and Covenants 124:143, looking for the reason why the Lord calls priesthood leaders and gives priesthood keys.

We learn the following truth in this verse: **The Lord calls priesthood leaders to govern the work of the ministry and help perfect the Saints.** (The work of the ministry and the perfecting of the Saints refers to the work of helping all of Heavenly Father’s children draw closer to Him and return worthily to His presence.) Consider marking the words or phrases that teach this truth in your scriptures.



**3.** In your scripture study journal, write about one or two ways your priesthood leaders have helped you to draw closer to your Heavenly Father.

### Doctrine and Covenants 125

*The Lord directs the Saints to gather to the places He appoints*

After the Saints were expelled from Missouri in the winter of 1838–39, they made their way into Illinois and Iowa, where they settled on both sides of the Mississippi River. The revelation contained in Doctrine and Covenants 125 was received in March 1841 and reveals the will of the Lord concerning the Saints in Iowa Territory. As you read Doctrine and Covenants 125, look for the directions the Lord gave to these Saints.

### Doctrine and Covenants 126

*Brigham Young is no longer required to leave his family to serve additional missions*

Imagine what it would be like to leave your family to serve missions for the Lord during the next five summers and then be called to serve a mission in a foreign country for nearly two years. How would you feel about leaving your family so many times? How would you feel about it if you were responsible for your family’s needs?

After Brigham Young joined the Church in April 1832, he served seven missions over the next nine years. His first mission was during the winter after he was baptized. Five others, including his participation in Zion’s Camp, occurred every summer from 1833 through 1837. These missions were from three to five months long. In 1839 Brigham Young, with the other Apostles, was called to serve a mission to Great Britain. They followed the Lord’s instructions to depart for this mission from Far West, Missouri, on April 26, 1839 (see D&C 118). Brigham and other Apostles spent the next few months in Iowa and Illinois, making further preparations to travel to Great Britain. An epidemic of malaria struck the area in the summer of 1839, and they, too, were stricken.

Read the following statement from Brigham Young, looking for evidence of Brigham’s attitude toward serving the Lord despite being so ill that he could not even get into the wagon without help when departing: “I was determined to go to England or to die trying. My firm resolve was that I would do what I was required to do in the Gospel of life and salvation, or I would die trying to do it” (*Teachings of Presidents of the Church: Brigham Young* [1997], 5).

Brigham Young's missionary service required sacrifice on the part of his family as well. Read the following summary of the circumstances of Brigham's family when he left for his mission to Great Britain:

Brigham Young left Montrose, Iowa, for Great Britain on September 14, 1839, just 10 days after his wife, Mary Ann, gave birth to their fourth child. Mary Ann was also suffering from malaria. This was the fifth time since they had been married that she had sent Brigham off on a mission. After being driven from their home and losing most of their possessions in Missouri the previous year, they were in the depths of poverty. Brigham was only able to leave Mary Ann with \$2.72 for their family. Brigham and Mary Ann trusted that the Lord would provide for them and relied on a promise from the Lord that the families of the Apostles would have their needs taken care of while the Apostles were away on their mission (see D&C 118:3).



Brigham Young directed the missionary work in the British Isles.

As Elders Brigham Young, Heber C. Kimball, and George A. Smith traveled toward the eastern United States for their mission to Great Britain, "Brigham reached into his trunk and always found just enough money for the next stage coach fare. He thought Heber was replenishing the fund, but later discovered that he had not. The brethren started their trip with \$13.50

in donations, yet they spent more than \$87 on coach fares. They had no idea how the additional money had gotten into the trunk 'except by some unseen agent from the Heavenly world to forward the promulgation of the Gospel' [in Leonard J. Arrington, *Brigham Young: American Moses* [1985], 77.]" (*Church History in the Fulness of Times Student Manual*, 2nd ed. [Church Educational System manual, 2003], 228).

As he directed the expansion of the missionary work throughout the British Isles, Brigham Young demonstrated great spiritual and administrative ability. Under the direction of Brigham Young and the other Apostles, the Church experienced phenomenal growth in Great Britain. By the time most of the Apostles completed their missions in the British Isles in late April 1841, more than 5,000 people had joined the Church, with approximately 1,000 of them having emigrated to Nauvoo a few months earlier.

"This mission was an important time of training and maturing for the Quorum of the Twelve Apostles. Brigham Young was able to strengthen the leadership skills that he would soon be called upon to exercise in Nauvoo. . . . Through trials and sacrifices in Britain, as well as laboring for a common goal, the Twelve were united in a way that assured the Church strong leadership in the years ahead" (*Church History in the Fulness of Times*, 234).

After leading the missionary work of the Church in Great Britain, Brigham Young arrived in Nauvoo, Illinois, on July 1, 1841. The Prophet Joseph Smith received the revelation recorded in Doctrine and Covenants 126 eight days later.

Read Doctrine and Covenants 126:1–3, looking for what the Lord told Brigham about his service. When have you felt that the Lord was pleased with your service?

From what you learn in verses 1–2, finish the following principle regarding the service we give: **If we labor diligently for the Lord, He will \_\_\_\_\_ our righteous offering.**

"In addition to being able to spend more time with his family after this revelation than he had been able to in the previous several years, Brigham Young was also near the Prophet Joseph Smith much of the time (twenty-eight of the last thirty-six months of Joseph's life).

"It seems clear that the Lord, knowing Brigham Young's future and the future of the Church, kept Brigham near Joseph so he could learn what he would need to know to lead the Church after Joseph's death" (*Doctrine and Covenants Student Manual*, 2nd ed. [Church Educational System manual, 2001], 313).



Because of his close association with the Prophet Joseph Smith, Brigham Young learned what he would need to know to lead the Church after Joseph's death.



Although Brigham Young was no longer required to leave his family to serve additional missions, he would serve several short-term missions before the Prophet's death. The Lord accepted Brigham Young's righteous offerings and diligent efforts in His work.

 **4. Think about opportunities you have to serve the Lord.** In your scripture study journal, write a few sentences explaining how you can follow the example of leaders such as Brigham Young to labor diligently in these opportunities.

 **5. Write the following at the bottom of today's assignments in your scripture study journal:**

*I have studied Doctrine and Covenants 124:84–145; 125–26 and completed this lesson on (date).*

*Additional questions, thoughts, and insights I would like to share with my teacher:*

## UNIT 27: DAY 3

# Doctrine and Covenants 127; 128:1–11

### Introduction

Doctrine and Covenants 127 contains a letter from the Prophet Joseph Smith, dated September 1, 1842, which instructed the Saints to keep records of the baptisms they performed for the dead. About a week later, Joseph wrote another letter concerning the subject of baptism for the dead. Doctrine and Covenants 128 contains this letter, which teaches why we keep records of saving ordinances that are performed.

### Doctrine and Covenants 127:1–4

#### *Joseph Smith glories in persecution and tribulation*

Read Doctrine and Covenants 127:1, looking for what tribulation the Prophet Joseph Smith was experiencing in Nauvoo, Illinois, in 1842.

In May 1842, Lilburn W. Boggs, the former governor of Missouri who issued the extermination order against the Saints, was wounded by an unknown would-be assassin. Missouri authorities accused the Prophet Joseph Smith of arranging for someone to murder Boggs and tried to bring the Prophet back to Missouri for trial. Joseph Smith had left Missouri years earlier and

was living in the area of Nauvoo, Illinois, at the time. Knowing that if he returned to Missouri he would be killed, the Prophet eluded Missouri officials for a time, to avoid being illegally arrested. In January 1843 it was determined that the proceedings to arrest Joseph Smith and extradite him to Missouri were illegal.

Doctrine and Covenants 127 was a letter, dated September 1, 1842, that the Prophet Joseph Smith wrote to the Church while he was moving about to avoid false arrest by Missouri officials. This letter was read to the Saints in Nauvoo a few days later.

Read Doctrine and Covenants 127:2, looking for how Joseph responded to tribulations. As you read, it might be helpful to know that the word *wont* means being accustomed to something.

 **1. Answer the following questions in your scripture study journal:**

- a. What was Joseph Smith's attitude toward tribulations?
- b. How can his example help us?

Based on what the Prophet wrote to the Saints, we can learn that **trusting in Heavenly Father can help us endure tribulation**. Review Doctrine and Covenants 127:2, and consider marking the words or phrases that teach this truth.

 **2. In your scripture study journal, write the name of a person you know (or have learned about) who was able to endure tribulation because he or she trusted in Heavenly Father. How did trusting in Heavenly Father help this person endure tribulation?**



The Prophet Joseph Smith assured the Saints that they could rejoice because “Israel’s God is their God” (D&C 127:3). Read Doctrine and Covenants 127:4, looking for what the Lord promised those who would endure persecution.



Ponder the faith of the Saints who continued to build the Nauvoo Temple even when they were under threat of persecution. How can their example influence you when you are faced with difficult challenges?

## Doctrine and Covenants 127:5–12

*The Prophet Joseph Smith counsels the Saints to keep records of the baptisms they perform for the dead*

Remember that about a year and a half before Joseph Smith wrote the letter now recorded in Doctrine and Covenants 127, the Lord had told the Saints that the ordinance of baptism for the dead belonged in the temple (see D&C 124:30). However, the Lord allowed the Saints to perform baptisms for the dead in the nearby river and streams until a baptismal font was ready in the temple. Once a font was ready, the ordinance of baptism for the dead was acceptable only in the temple. The Saints began performing baptisms for the dead in the Nauvoo Temple in November 1841.



Have you been able to go to the temple and perform baptisms for the dead? If so, did you notice whether anyone was sitting near the baptismal font?

Read Doctrine and Covenants 127:5–9, looking for who needs to be present when baptisms for the dead are performed.

According to verse 7, why is it important that a recorder be an eyewitness to the baptisms?

In addition to the need for a recorder, we can also learn from verse 7 that **the temple ordinances we perform on the earth are binding in heaven**. You might want to mark the words or phrases that teach this doctrine. To be binding in heaven means that the ordinances are valid in the sight of Heavenly Father.



3. Answer the following question in your scripture study journal: How might this doctrine affect you when participating in ordinances for the dead?

In Doctrine and Covenants 127:10–12, we learn that Joseph Smith wanted to teach the Saints more about baptism for the dead, but because he was in hiding, he could not do so. He promised to write the Saints additional letters about baptism for the dead and other important subjects.

## Doctrine and Covenants 128:1–11

*Joseph Smith explains why we keep records for ordinances of salvation*

About a week after he wrote the letter recorded in Doctrine and Covenants 127, the Prophet Joseph Smith wrote another letter to the Saints concerning baptism for the dead. The contents of this letter are in Doctrine and Covenants 128.

In Doctrine and Covenants 128:1–5, Joseph Smith taught that local recorders should be appointed to witness and record the ordinance of baptism for the dead. He also taught that a general recorder should be appointed to compile the local records onto a general Church record.

Have you ever seen a passport? What kinds of privileges is the holder of the passport entitled to? Why will another person's passport *not* qualify you to enter another country? What could happen if you tried to enter another country but the information inside your passport was not complete?

Read Doctrine and Covenants 128:6–7, looking for what records will be used to determine whether we qualify to be admitted into God's presence. Notice that the Apostle John and the Prophet Joseph Smith mentioned more than one record. They told of "the books [that] were opened; and another book, . . . which is the book of life" (D&C 128:6; see also Revelation 20:12). The first books spoken of by John are records kept on the earth, and the book of life is the record kept in heaven. These books contain a record of our works.

Just like a person needs specific information recorded in his or her passport to be admitted into another country, we need specific information to be recorded in these books in order to be admitted into God's presence.

President Boyd K. Packer of the Quorum of the Twelve Apostles taught:



“No matter what citizenship or race, whether male or female, no matter what occupation, no matter your education, regardless of the generation in which one lives, life is a homeward journey for all of us, back to the presence of God in His celestial kingdom.

“Ordinances and covenants become our credentials for admission into His presence. To worthily receive them is the quest of a lifetime; to keep them thereafter is the challenge of mortality” (“Covenants,” *Ensign*, May 1987, 24).

Consider marking the phrase “whatsoever you bind on earth shall be bound in heaven” in Doctrine and Covenants 128:8. Then read Doctrine and Covenants 128:8 again, looking for “a different view of the translation” Joseph Smith gave of this statement. You may want to mark that phrase as well.

As you read verse 8, it might help to know that *propria persona* means to act in one’s own behalf and refers to people who are baptized for themselves. The phrase “their own agents” refers to those who were not able to receive the saving ordinance of baptism during mortality and need agents—other people—to be baptized for them.

According to Doctrine and Covenants 128:8, what two things need to happen in order for ordinances to be binding on earth and in heaven? To answer this question, fill in the blanks of the following doctrine:

**When an ordinance is performed by priesthood \_\_\_\_\_ and a proper \_\_\_\_\_ is kept, the ordinance is binding on earth and in heaven.**



**4.** Answer the following questions in your scripture study journal:

- a. What do you think it means for an ordinance to be binding in heaven?
- b. How do you feel as you think about your participation in the temple ordinances of baptism and confirmation bringing blessings to people in the spirit world?

Read Doctrine and Covenants 128:9, looking for what Joseph Smith said about this principle.

One of the things we learn in verse 9 is that in every dispensation of the priesthood, the Lord has authorized at least one of His servants to hold and use the sealing keys of the priesthood.



Read Doctrine and Covenants 128:10–11, looking for what the Savior gave to Peter.

Just as the Savior gave the sealing keys of the priesthood to Peter, He has given the keys again in our day.



**5.** Answer the following questions in your scripture study journal:

- a. Why is it important that ordinances, such as baptisms for the dead, be done with the proper authority?
- b. What will you do because of what you have learned today?



**6.** Write the following at the bottom of today’s assignments in your scripture study journal:

*I have studied Doctrine and Covenants 127; 128:1–11 and completed this lesson on (date).*

*Additional questions, thoughts, and insights I would like to share with my teacher:*

# Doctrine and Covenants 128:12–25

## Introduction

This lesson covers the remaining portion of a letter the Prophet Joseph Smith wrote to the Saints in early September 1842. In this portion of the letter, the Prophet taught about the salvation of the living and the dead. He also encouraged the Saints to be faithful in their work for the dead and expressed his joy in the Restoration of the gospel.

## Doctrine and Covenants 128:12–18

*Joseph Smith teaches about the salvation of the living and the dead*

Imagine you are attending a temple open house with a friend who is not a member of the Church. As you walk through the baptistry, your friend asks, “Why do you get baptized for dead people?” Your friend also asks, “Is baptism for the dead discussed in the Bible?”

As you study today’s lesson, you will discover principles that can help you answer these questions.

You might recall from the previous lesson that in September 1842, the Prophet Joseph Smith was hiding from men who were unlawfully seeking to arrest him.

While in hiding, he wrote a letter to the Saints. In this letter he taught them about baptism for the dead.

Read Doctrine and Covenants 128:12–13, looking for what Joseph Smith taught about the symbolism of baptism.

 **1.** In your scripture study journal, write a few lines explaining how you could use the teachings in verses 12–13 to help someone understand why baptism is done by immersion.

As you read Doctrine and Covenants 128:14, notice how Joseph Smith emphasized the importance of keeping an acceptable record before the Lord concerning the work of salvation for the dead.

Study Doctrine and Covenants 128:15, looking for reasons why we perform baptisms for the dead.

In verse 15, the phrase “they without us cannot be made perfect” means that **our ancestors who die without the gospel cannot progress toward perfection until the saving ordinances of the gospel have been performed for them.**

Read the following information, marking phrases that indicate how you can help your ancestors who died without receiving the gospel:

“Your deceased ancestors live in a place called the spirit world. There they have the opportunity to hear and accept the gospel of Jesus Christ. However, they cannot receive the ordinances of the gospel for themselves, and they cannot progress until others provide these ordinances for them.





“Your privilege and responsibility is to give your ancestors this gift by identifying them and ensuring that ordinances are performed in their behalf in the temple. They may then choose whether to accept the work that has been done” (*Member’s Guide to Temple and Family History Work* [2009], 2).

 **2.** Answer the following question in your scripture study journal: How do you think your ancestors might feel toward you when you are baptized for them? If you have had the opportunity to participate in baptisms for the dead, also write about the feelings you have had during that experience.

Review Doctrine and Covenants 128:15, looking for another reason we perform baptisms for the dead. Based on what you learn, complete the following doctrine: **The salvation of our deceased ancestors is \_\_\_\_\_ to our salvation.**

As you continue to study Doctrine and Covenants 128, ponder why doing family history work and temple work for our deceased ancestors are essential to our salvation.

Read Doctrine and Covenants 128:16–17, looking for teachings from an Apostle in the New Testament and a prophet in the Old Testament. Why might it be helpful to know that the Bible includes teachings about work for the dead?

Have you ever looked closely at a metal chain? To make a chain strong, each link is welded shut after being connected through another link.



Read Doctrine and Covenants 128:18, looking for how the links of a chain relate to the Prophet Joseph Smith’s teachings about baptism for the dead. (Remember that a *dispensation* is a period of time when the Lord reveals His doctrines, ordinances, and priesthood [see Bible Dictionary, “Dispensations”]. In this verse, the word *children* refers to us and the word *fathers* refers to our ancestors.)

You may want to write the following doctrine in your scriptures near verse 18: **Baptism for the dead helps to link us eternally to our ancestors.**

In addition to baptism, the other saving ordinances—confirmation, Melchizedek priesthood ordination (for men), the temple endowment, and the sealing ordinance—are also essential to secure the welding link between our ancestors and ourselves.

To increase your understanding of the truths in Doctrine and Covenants 128, study the following statement by President Joseph Fielding Smith:



“Some members of the Church have wondered just what was meant by the words of the Prophet, that we without our dead could not be made perfect. Will not a man who keeps the commandments of the Lord, who is faithful and true so far as he himself is concerned, receive perfection? Yes, provided his worthy dead also receive the same privileges, because there must be a family organization, a family unit, and each generation must be linked to the chain that goes before in order to bring perfection in family organization. Thus eventually we will be one large family with Adam at the head, Michael, the archangel, presiding over his posterity” (*Doctrines of Salvation*, comp. Bruce R. McConkie, 3 vols. [1954–56], 2:175).

According to Doctrine and Covenants 128:18, why is it important to be part of this chain of people who have been linked or sealed together?

The following statements can help you understand what the curse in verse 18 refers to:

President Joseph Fielding Smith said: “If there is not a welding link between the fathers and the children—which is the work for the dead—then we will all stand rejected; the whole work of God will fail and be utterly wasted” (*Doctrines of Salvation*, 2:122).



Elder L. Tom Perry of the Quorum of the Twelve Apostles taught: “The eternal family is central to the gospel of our Savior. There would be no reason for Him to return to earth to rule and reign over His kingdom unless the eternal family unit has been established for our Father in Heaven’s children. When we understand the eternal role of the family, the nourishing and developing of strong family ties take on even greater significance” (“Youth of the Noble Birthright,” *Ensign*, Nov. 1998, 74).

 **3.** Answer the following question in your scripture study journal: Based on what you have learned from your study of Doctrine and Covenants 128, why are family history work and temple work essential to our salvation?



## Doctrine and Covenants 128:19–25

*Joseph Smith expresses joy in the Restoration of the gospel and encourages the Saints to be faithful as they work for the salvation of the dead*

Think about a time when you have been happy to hear really good news. When you heard it, did you want to share it with others? Why?

Read Doctrine and Covenants 128:19. The word *tidings* in this verse is another word for *news*. Look for the tidings the Prophet Joseph Smith said we have received.

In what ways is the gospel of Jesus Christ a voice of gladness both for the living and the dead?

In Doctrine and Covenants 128:20–21, we read about some of the experiences Joseph Smith had with heavenly messengers as the gospel was restored through him.

One truth we learn from these verses is that **the keys, powers, and authority of the past dispensations have been restored in the dispensation of the fulness of times**. Consider writing this truth in your scriptures or in your scripture study journal.



President John Taylor said: “If you were to ask Joseph what sort of a looking man Adam was, he would tell you at once; he would tell you his size and appearance and all about him. You might have asked him what sort of men Peter, James and

John were, and he could have told you. Why? Because he had seen them” (in *Teachings of Presidents of the Church: Joseph Smith* [2007], 103).



**4.** Answer the following question in your scripture study journal: How does knowing that the gospel was restored to the earth through heavenly messengers influence your faith and your testimony of the Restoration?

Doctrine and Covenants 128:22–23 contains expressions of the joy the Prophet Joseph Smith felt because the keys of the priesthood had been restored and because the Saints could help redeem the dead. As you study these verses, you may want to mark phrases that are meaningful to you.

Read Doctrine and Covenants 128:24, looking for an offering that the Prophet instructed the Saints to make to the Lord. What can you do to contribute to this “book”?

Ponder the following truth: **When we do family history work and receive temple ordinances for our ancestors, we make a righteous offering to the Lord.** As you think about this truth, read the following statement, in which Elder David A. Bednar of the Quorum of the Twelve Apostles described your role in the work for the salvation of the dead:



“Many of you may think family history work is to be performed primarily by older people. But I know of no age limit described in the scriptures or guidelines announced by Church leaders restricting this important service to mature adults.

You are sons and daughters of God, children of the covenant, and builders of the kingdom. You need not wait until you reach an arbitrary age to fulfill your responsibility to assist in the work of salvation for the human family. . . .

“It is no coincidence that . . . tools have come forth at a time when young people are so familiar with a wide range of information and communication technologies. . . . The skills and aptitude evident among many young people today are a preparation to contribute to the work of salvation.

“I invite the young people of the Church to learn about and experience the Spirit of Elijah. I encourage you to study, to search out your ancestors, and to prepare yourselves to perform proxy baptisms in the house of the Lord for *your* kindred dead (see D&C 124:28–36). And I urge you to help other people identify their family histories” (“The Hearts of the Children Shall Turn,” *Ensign* or *Liahona*, Nov. 2011, 26–27).

### Apply Doctrines and Principles

Application takes place when you think, speak, and live according to the doctrines and principles you have learned from the scriptures. As you apply doctrines and principles in your life, you will receive blessings. You will gain a deeper understanding and testimony of the doctrines and principles you have applied.



## UNIT 28: DAY 1

# Doctrine and Covenants 129; 130:1–11, 22–23

## Introduction

On February 9, 1843, the Prophet Joseph Smith made known “three grand keys” (D&C 129:9) for distinguishing the nature of ministering angels and spirits. These instructions are recorded in Doctrine and Covenants 129. Doctrine and Covenants 130 contains the Prophet’s teachings on various doctrines while meeting with Saints in Ramus, Illinois, on April 2, 1843.

## Doctrine and Covenants 129

*The Prophet Joseph Smith gives instructions concerning the nature of ministering angels and spirits*

If someone were to ask you if Latter-day Saints believe in angels, what would you tell them?

Read the following statement by Elder Jeffrey R. Holland of the Quorum of the Twelve Apostles:



“From the beginning down through the dispensations, God has used angels as His emissaries in conveying love and concern for His children. . . .

“Usually such beings are *not* seen.

Sometimes they are. But seen or unseen they are *always* near. Sometimes their assignments are very grand and have significance for the whole world. Sometimes the messages are more private. Occasionally the angelic purpose is to warn. But most often it is to comfort, to provide some form of merciful attention, guidance in difficult times” (“The Ministry of Angels,” *Ensign* or *Liahona*, Nov. 2008, 29).

Beginning in 1839 and continuing through 1843, the Prophet Joseph Smith gave instructions to several people to help them know how to distinguish the nature of ministering angels and spirits.

Read Doctrine and Covenants 129:1–3, looking for an important difference between angels and spirits. (It may be helpful to know that the word *just* means righteous.) How are angels different from spirits?

 **5.** To apply what you have learned today, make a plan to help some of your ancestors receive temple ordinances. You may want to work with your parents or a ward or branch family history consultant as you make this plan. Write your plan in your scripture study journal as follows:

- a. My plan to find the names of ancestors who need temple ordinances:
- b. My plan to accomplish temple work for my ancestors: (If possible, make a plan to attend the temple to receive baptisms and confirmations for the ancestors you identify.)

 **6.** Write the following at the bottom of today’s assignments in your scripture study journal:

*I have studied Doctrine and Covenants 128:12–25 and completed this lesson on (date).*

*Additional questions, thoughts, and insights I would like to share with my teacher:*

Read Doctrine and Covenants 129:4–7, looking for a way to distinguish between angels and righteous spirits.

To fully understand verse 7, remember that because spirits do not have bodies of flesh and bones, they cannot clasp hands with mortals. If spirits pretend to have an ability they do not possess, that would be deceit, and a spirit who would attempt this would not be a “just man.” Therefore, the spirits of just men made perfect will not try to shake hands when a hand is extended toward them. From Doctrine and Covenants 129:7, we learn that **true messengers sent from Heavenly Father will not deceive us.**

The devil sometimes tries to appear as “an angel of light” in order to deceive people (see D&C 129:8). In addition, “the scriptures also speak of the devil’s angels. These are those spirits who followed Lucifer and were thrust out of God’s presence in the premortal life and cast down to the earth (Rev. 12:1–9; 2 Ne. 9:9, 16; D&C 29:36–37)” (Guide to the Scriptures, “Angels”; scriptures.lds.org).

Read Doctrine and Covenants 129:8–9, looking for how to recognize an evil spirit who seeks to deceive by appearing as an angel of light. (It may help to know that the word *administration* in verse 9 refers to a manifestation or visit from an angel or a spirit.)

The following statement by the Prophet Joseph Smith may help you understand why evil spirits will always comply with the instructions in Doctrine and Covenants 129: “It would seem . . . that wicked spirits have their bounds, limits, and laws by which they are governed and controlled, and know their future destiny” (in *History of the Church*, 4:576).

 **1.** In your scripture study journal, summarize what you have learned from Doctrine and Covenants 129 about the differences between angels, righteous spirits, and evil spirits. Explain what else, in addition to the instruction in these verses, Heavenly Father has given you to help you discern Satan’s deceptions.

## Doctrine and Covenants 130:1–11, 22–23

### *The Prophet Joseph Smith clarifies various doctrines*

On April 2, 1843, the Prophet Joseph Smith held a stake conference with Saints in Ramus, Illinois, which was about 20 miles southeast of Nauvoo. During a morning meeting, Elder Orson Hyde of the Quorum of the Twelve Apostles preached a sermon and taught an interpretation of scripture that was not correct, which he had learned from his previous association with a different church. What responsibility did the Prophet have in this situation?

Presiding leaders in the Church, such as prophets, stake presidents, and bishops, have the responsibility to ensure that correct doctrine is taught in Church settings. After the morning meeting, Joseph Smith, Orson Hyde, and a few others had lunch at the home of Joseph’s sister Sophronia. During lunch the Prophet told Elder Hyde that he “was going to offer some corrections to his sermon.” Elder Hyde responded, “They shall be thankfully received” (in *History of the Church*, 5:323).



Orson Hyde

In his morning remarks, Orson Hyde had misinterpreted John 14:23. Take a moment to study this verse.

After Orson Hyde referred to this verse, he told the people that “it is our privilege to have the Father and Son dwelling in our hearts” (in *History of the Church*, 5:323). Doctrine and Covenants 130 contains the Prophet Joseph

Smith’s correction of this idea. It also includes some additional teachings.

Read Doctrine and Covenants 130:1–3, looking for why Orson Hyde’s statement regarding the meaning of John 14:23 was incorrect.

Many people today either have no concept of God or, perhaps like Orson Hyde, who was once a Campbellite preacher, have an incorrect perception of the nature of Deity because of false traditions. We can help others understand Heavenly Father’s true nature and their relationship to Him.

 **2.** Answer the following question in your scripture study journal: In conversations with people who have false traditions or beliefs about God, how can you be kind and understanding when you share what you know about God’s true nature—what He is really like?

Study Doctrine and Covenants 130:22–23, looking for truths the Prophet Joseph Smith taught about the Godhead. (Doctrine and Covenants 130:22–23 is a scripture mastery passage. You may want to mark it in a distinctive way to help you locate it in the future.)

 **3.** Complete the following assignments in your scripture study journal:

**a.** From what you learn in Doctrine and Covenants 130:22–23, write two or three doctrines about the Godhead.



- b. Write a sentence or two explaining how you could use the truths taught in verses 22–23 to teach others about the Godhead.
- c. Why do you think it is important to understand that Heavenly Father and Jesus Christ are separate individuals with bodies of flesh and bones?

Many traditions about God the Father, Jesus Christ, and the Holy Ghost are based on ideas thought up by mortal men and women. Some of these ideas have developed as a result of debates between religious leaders. Our knowledge of the Godhead comes through revelation from God to His prophets. The following statements summarize revealed truths about the Godhead. As you read them, mark words and phrases that stand out to you.



*“God the Father:* It is generally the Father, or Elohim, who is referred to by the title God. He is called the Father because He is the father of our spirits. . . . God the Father is the supreme ruler of the universe. He is all powerful . . . , all knowing . . . , and everywhere present through his Spirit. . . . Mankind has a special relationship to God that sets man apart from all other created things: men and women are God’s spirit children” (Guide to the Scriptures, “God, Godhead”; scriptures.lds.org).

*“God the Son:* The God known as Jehovah is the Son, Jesus Christ. . . . Jesus works under the direction of the Father and is in complete harmony with Him. All mankind are His brothers and sisters, for he is the eldest of the spirit children of Elohim” (Guide to the Scriptures, “God, Godhead”; scriptures.lds.org). He is the Redeemer, and He suffered the sins and pains of all mankind and overcame physical death for all.

*“God the Holy Ghost:* The Holy Ghost is also a God and is called the Holy Spirit, the Spirit, and the Spirit of God, among other similar names and titles [such as the Comforter]. With the aid of the Holy Ghost, man can know the will of God the Father and know that Jesus is the Christ” (Guide to the Scriptures, “God, Godhead”; scriptures.lds.org). The primary role of the Holy Ghost is to bear witness of God the Father and Jesus Christ. The Holy Ghost teaches and confirms truth.

- 4. In your scripture study journal, write a few sentences summarizing what you have learned about the Godhead. Explain which truths stood out to you and why. You may also want to include your testimony of the Godhead.

Review Doctrine and Covenants 130:2. As you do so, you may want to mark the words that teach the following doctrinal statement: **The relationships we can have in heaven are the same as those we enjoy on earth, but they will include eternal glory.** (The word *sociality* in verse 2 refers to the nature of our personal interactions and relationships.)



President Henry B. Eyring of the First Presidency shared his testimony of these eternal relationships: “Because of the restoration of the knowledge of eternal families, we are more hopeful and more kindly in all our family relations. The greatest joys in this life center in families, as they will in the worlds to come. I am so grateful for the assurance I have that if we are faithful, the same sociality which we enjoy here in this life will be forever with us in the world to come, in eternal glory. [See D&C 130:2.]” (“The True and Living Church,” *Ensign* or *Liahona*, May 2008, 22).

- 5. Complete the following assignments in your scripture study journal:
  - a. Answer the following question: How can knowing that our relationships on earth continue in eternal glory in heaven influence your interactions with others?
  - b. Think about one thing you can do to strengthen your relationships with others, especially members of your family. Then write a goal to do so.



Some additional doctrines taught by the Prophet Joseph Smith in Ramus, Illinois, are contained in Doctrine and Covenants 130:4–11. Read these verses, looking for the Prophet’s teachings about angels and about the future of the earth. According to verses 10–11, all who inherit the celestial kingdom will receive a Urim and Thummim to help them learn about and understand heavenly things. The Prophet did not elaborate on this teaching.

## Scripture Mastery—Doctrine and Covenants 130:22–23

 6. Elder Jeffrey R. Holland said, “We declare it is self-evident from the scriptures that the Father, the Son, and the Holy Ghost are separate persons, three divine beings” (“The Only True God and Jesus Christ Whom He Hath Sent,” *Ensign* or *Liahona*, Nov. 2007, 41). To see how the doctrine of the Godhead is clearly taught in the scriptures, find at least three passages in the New Testament that teach the doctrine Elder Holland described. Using the scripture study aids, such as the Topical Guide, the index in your scriptures, and the Guide to the Scriptures, would be helpful. Write the references to the passages you find in your scripture study journal. You may also want to write them in your scriptures near Doctrine and Covenants 130:22–23.

 7. Write the following at the bottom of today’s assignments in your scripture study journal:

*I have studied Doctrine and Covenants 129; 130:1–11, 22–23 and completed this lesson on (date).*

*Additional questions, thoughts, and insights I would like to share with my teacher:*

## UNIT 28: DAY 2

# Doctrine and Covenants 130:12–21

## Introduction

This lesson includes doctrines the Prophet Joseph Smith taught at a Church meeting in Ramus, Illinois, on April 2, 1843. These instructions are recorded in Doctrine and Covenants 130. The Prophet taught about future events, including the Second Coming of Jesus Christ. He also taught about our ability to retain knowledge and intelligence after we die and explained how we can receive God’s blessings.

## Doctrine and Covenants 130:12–17

### *Joseph Smith teaches about the Second Coming*

Have you ever wanted to know exactly when the Second Coming of Jesus Christ will happen?

Many others have wondered the same thing. In Joseph Smith’s day, a prominent Christian preacher named William Miller claimed the Savior’s Second Coming would happen on April 3, 1843. One day before Miller’s predicted date of the Second Coming, the Prophet Joseph Smith spoke to the Saints in Ramus, Illinois, and mentioned that he had prayed to know the time of the Second Coming.

Read Doctrine and Covenants 130:14–17, looking for what Joseph Smith learned when he prayed about the timing of the Second Coming of Jesus Christ.

Notice that the Lord did not reveal to Joseph Smith the exact date of the Second Coming. Furthermore, He instructed Joseph: “Trouble me no more on this matter” (D&C 130:15). Look at the scripture references in Doctrine and Covenants 130:15, footnote *a*. These passages further emphasize that no one knows exactly when the Savior will return.

In the following statement, underline what Elder M. Russell Ballard of the Quorum of the Twelve Apostles said about who knows when the Second Coming will occur:



“I am called as one of the Apostles to be a special witness of Christ in these exciting, trying times, and I do not know when He is going to come again. As far as I know, none of my brethren in the Quorum of the Twelve or even in the First Presidency

knows. And I would humbly suggest that if we do not know, then nobody knows, no matter how compelling their arguments or how reasonable their calculations. The Savior said that ‘of that day, and hour, no one knoweth; no, not the angels of God in heaven, but my Father only’ [Joseph Smith—Matthew 1:40].

“I believe that when the Lord says ‘no one’ knows, He really means that no one knows. We should be extremely wary of anyone who claims to be an exception to divine decree” (“When Shall These Things Be?” *Ensign*, Dec. 1996, 56).

From Doctrine and Covenants 130:14–17 and Elder Ballard’s statement, we learn that **only God knows the exact time when the Second Coming will occur.**

 1. Answer the following question in your scripture study journal: How can remembering this truth help you to not be misled by false claims?

## Doctrine and Covenants 130:18–19

*Joseph Smith teaches about the importance of gaining knowledge and intelligence in this life*



Imagine you are leaving home and going somewhere you have never been before. You are allowed to take only what will fit in one suitcase. What would you pack in your suitcase?

What if your destination is the spirit world (where our spirits go after we die)? Which of the items you chose to pack in your suitcase would you be able to take with you when you die?

Read Doctrine and Covenants 130:18–19, looking for what we can take with us from this life when we die.

According to verses 18–19, what will be with us after we die? To answer this question, complete the following principle: **The \_\_\_\_\_ and \_\_\_\_\_ we gain in this life will rise with us in the resurrection.**



Elder Neal A. Maxwell of the Quorum of the Twelve Apostles helped us understand the meaning of the word *intelligence* in these verses: “If we ponder just what it is that will rise with us in the resurrection, it seems clear that our intelligence will rise with us, meaning not simply our IQ, but also our capacity to receive and apply truth. Our talents, attributes, and skills will rise with us; certainly also our capacity to learn, our degree of self-discipline, and our capacity to work” (*We Will Prove Them Herewith* [1982], 12).



**2. Answer the following questions in your scripture study journal:**

- According to Doctrine and Covenants 130:19, how can we gain greater knowledge and intelligence?
- When have you gained knowledge or intelligence through your diligence and obedience? What did you experience?

Notice that according to verse 19, those who gain more knowledge and intelligence in this life will have an advantage in the world to come. This means that what

we learn in this life, both temporally and spiritually, will be helpful to us throughout eternity. We will be able to build upon the knowledge we obtain in this life to become more like Heavenly Father.



**3. In your scripture study journal, write a goal that can help you gain more knowledge and intelligence.**

## Doctrine and Covenants 130:20–21

*Joseph Smith explains how we obtain blessings*

Imagine that you want to improve your penmanship, so you decide to run three miles, five days a week, for one month. How will this training affect your penmanship?



If you want to improve your penmanship, what do you need to do?

Just as we need to understand how to obtain the results we desire, we need to understand how to obtain the blessings Heavenly Father desires to give to us.

Read Doctrine and Covenants 130:20–21, looking for how we can obtain the blessings Heavenly Father desires to give to us. It may be helpful to know that the word *predicated* means “based on” and that the phrase “irrevocably decreed” means that a law is permanent and unchangeable.

Based on what you learned in verses 20–21, complete the following principle: **If we want to obtain a \_\_\_\_\_, then we must \_\_\_\_\_.**

To help you further understand this principle, complete the following chart. Read the scripture passages, and then identify the law and an associated blessing described in each passage.

Scripture Passage	Law	Blessing
D&C 10:5		
2 Nephi 32:3		
Malachi 3:8–10; D&C 64:23		
D&C 89:18–21		

understanding of the finite. When he preached to the people—revealed the things of God, the will of God, the plan of salvation, the purposes of Jehovah, the relation in which we stand to him and all the heavenly beings—he reduced his teachings to the capacity of every man, woman, and child, making them as plain as a well-defined pathway. This should have convinced every person that ever heard him of his divine authority and power, for no other man was able to teach as he could, and no person can reveal the things of God, but by the revelations of Jesus Christ” (*Teachings of Presidents of the Church: Brigham Young* [1997], 347).

 **5.** Answer the following question in your scripture study journal: How do the principles in Doctrine and Covenants 129–30 strengthen your testimony of the calling of Joseph Smith?

 **6.** Write the following at the bottom of today’s assignments in your scripture study journal:

*I have studied Doctrine and Covenants 130:12–21 and completed this lesson on (date).*

*Additional questions, thoughts, and insights I would like to share with my teacher:*

 **4.** Complete the following assignments in your scripture study journal:

- Answer the following question: What blessings have you received because you obeyed a law?
- Think about blessings you want to obtain. Write what law or laws you will need to obey so you can receive those blessings. (You could use scripture study aids like the Guide to the Scriptures or the Topical Guide to help you find laws that help bring blessings. It is important to remember that some laws and blessings are very specific while others are more general. It is also important to remember that some promised blessings may come after mortality.)



Review the doctrines and principles you have discovered in Doctrine and Covenants 130. Ponder these doctrines and principles as you read the following statement by President Brigham Young concerning the Prophet Joseph Smith’s ability to explain the things of God: “The excellency of the glory of the character of Brother Joseph Smith was that he could reduce heavenly things to the

## UNIT 28: DAY 3

# Doctrine and Covenants 131

## Introduction

Doctrine and Covenants 131 contains a compilation of principles the Prophet Joseph Smith taught while in Ramus, Illinois, on May 16–17, 1843. He taught about the new and everlasting covenant of marriage and the promise of eternal life for the faithful. He also taught that all spirit is matter.

## Doctrine and Covenants 131:1–4

*Joseph Smith teaches about the importance of the eternal marriage covenant*

Why do the Lord and Church leaders place so much emphasis on being married in the temple? Doctrine and Covenants 131 helps us answer that question. So does Doctrine and Covenants 132, which you will study in the next lesson.



On May 16, 1843, the Prophet Joseph Smith traveled to Ramus, Illinois. While staying at the home of Benjamin and Melissa Johnson, he performed their sealing as husband and wife for eternity (this ordinance was temporarily authorized until the temple was complete). He also taught them how eternal marriage is related to the celestial kingdom. These truths are recorded in Doctrine and Covenants 131:1–4. (See *History of the Church*, 5:391–92.)

Read Doctrine and Covenants 131:1, looking for a truth the Prophet revealed about the celestial kingdom. Then complete the following sentence: There are \_\_\_\_\_ heavens or degrees within the celestial kingdom.

We often refer to receiving the highest degree of glory within the celestial kingdom as exaltation or eternal life. Those who obtain this degree of celestial glory will live the same type and quality of life our Heavenly Father lives.

Read Doctrine and Covenants 131:2–4, looking for what we must do in order to obtain the highest degree of the celestial kingdom. (Doctrine and Covenants 131:1–4 is a scripture mastery passage. You may want to mark these verses in a distinctive way so that you can find them easily later.)

From what you learn in verse 2, complete the following doctrinal statement: **In order to obtain the highest degree of the celestial kingdom, we must enter into \_\_\_\_\_.**

In Doctrine and Covenants 131:4, we learn that if we are not sealed in the temple by the proper authority, we “cannot have an increase.” *Increase* refers to the opportunity to continue to have children in the celestial kingdom.

Notice the phrase “new and everlasting covenant of marriage” in verse 2. The word *new* in this context means that this covenant was newly restored in our dispensation. The term *everlasting* means that this essential covenant will endure throughout eternity. We enter into this covenant of celestial marriage only in the temple.

In what ways do you think celestial marriage between a man and a woman prepares them for exaltation? Elder David A. Bednar of the Quorum of the Twelve Apostles gave some important insight into this question. As you read what he taught, mark words or phrases that explain how celestial marriage helps prepare us for eternal life.



“Two compelling doctrinal reasons help us to understand why eternal marriage is essential to the Father’s plan.

**“Reason 1:** *The natures of male and female spirits complete and perfect each other, and therefore men and women are intended to progress together toward exaltation. . . .*

“By divine design, men and women are intended to progress together toward perfection and a fulness of glory. Because of their distinctive temperaments and capacities, males and females each bring to a marriage relationship unique perspectives and experiences. The man and the woman contribute differently but equally to a oneness and a unity that can be achieved in no other way. The man completes and perfects the woman and the woman completes and perfects the man as they learn from and mutually strengthen and bless each other. . . .



**“Reason 2:** *By divine design, both a man and a woman are needed to bring children into mortality and to provide the best setting for the rearing and nurturing of children . . .*

“A home with a loving and loyal husband and wife is the supreme setting in which children can be reared in love and righteousness and in which the spiritual and physical needs of children can be met. Just as the unique characteristics of both males and females contribute to the completeness of a marriage relationship, so those same characteristics are vital to the rearing, nurturing, and teaching of children” (“Marriage Is Essential to His Eternal Plan,” *Ensign*, June 2006, 83–84; or *Liahona*, June 2006, 51–52).



**1.** Answer the following questions in your scripture study journal:

- a. How could understanding the doctrine that celestial marriage is essential for exaltation affect what you look for in a future spouse?
- b. Why is it important at your age to make it a priority to prepare to receive “the new and everlasting covenant of marriage” (D&C 131:2) in the temple?

The blessings of exaltation are available to those who do not have the opportunity for a celestial marriage in this life: “Some members of the Church remain single through no fault of their own, even though they want to marry. If you find yourself in this situation, be assured that ‘all things work together for good to them that love God’ (Romans 8:28). As you remain worthy, you will someday, in this life or the next, be given all the blessings of an eternal family relationship. The Lord has made this promise repeatedly through His latter-day prophets” (*True to the Faith: A Gospel Reference* [2004], 99).

## Scripture Mastery—Doctrine and Covenants 131:1–4



**2.** Read Doctrine and Covenants 131:1–4 three times. Draw a picture that helps explain the truths in these verses. Find an opportunity to teach this scripture mastery passage to a family member or friend. Consider using your picture to help you explain the truths. In your scripture study journal, write about who you taught and when.

## Doctrine and Covenants 131:5–6

*Joseph Smith explains the “more sure word of prophecy”*

A guarantee is a promise or an assurance that something will be done in the future.

Consider the following questions: What are the benefits of having a guarantee? Why would a guarantee from Heavenly Father be especially valuable?

In Ramus, Illinois, on the morning of May 17, 1843, the Prophet Joseph Smith gave a sermon on a phrase found in 2 Peter 1:19 that represents a guarantee from God (see *History of the Church*, 5:392). Turn to 2 Peter 1:19, and locate the phrase “more sure word of prophecy.” Then read Doctrine and Covenants 131:5 to learn what “more sure word of prophecy” means.



**3.** According to Doctrine and Covenants 131:5, what does Heavenly Father guarantee to a person through the more sure word of prophecy? In your scripture study journal, write about how you would feel if you received such a guarantee.

Some individuals receive this assurance of eternal life while still in mortality. Sometimes we see phrases in the scriptures that represent the Lord giving this guarantee to certain individuals. For example, the Lord expressed this assurance to Joseph Smith in Doctrine and Covenants 132:49 and to Alma in Mosiah 26:20. However, this is a private matter between an individual and the Lord; we should not speculate about individuals who have received the “more sure word of prophecy.”

Read Doctrine and Covenants 131:6, looking for something that would prevent someone from receiving eternal life.

What did the Prophet Joseph Smith say would make it impossible for a person to be saved, or receive eternal life? Complete the following principle: **We cannot be saved** \_\_\_\_\_.



President Marion G. Romney of the First Presidency gave an explanation of what this means: “Knowledge of ‘the only true God, and Jesus Christ’ (John 17:3) is the most important knowledge in the universe; it is the knowledge without which the Prophet Joseph Smith said no man could be saved. The lack of it is the ignorance referred to in the revelation wherein it is written: ‘It is impossible for a man to be saved in ignorance.’ (D&C 131:6.)” (“Except a Man Be Born Again,” *Ensign*, Nov. 1981, 14).

### Learn How to Cross-Reference

Cross-references connect scripture passages in ways that can help you understand the doctrines and principles in those passages. Helpful cross-references can be found in the footnotes and other scripture study aids. You can also discover cross-references in your own study.



4. Answer the following questions in your scripture study journal:

- What kind of knowledge must we have in order to receive eternal life? Why do you think this kind of knowledge is essential for salvation?
- What will you do to increase in your knowledge of Heavenly Father and Jesus Christ?

### Doctrine and Covenants 131:7–8

*Joseph Smith teaches that all spirit is matter*

Read Doctrine and Covenants 131:7–8, looking for what spirits are composed of.

These verses teach that all creations are composed of matter, but spirit matter “is more fine or pure” (D&C 131:7). Matter is the substance that objects are made of. The Prophet Joseph Smith explained that our spirits are made of very fine or pure matter that cannot be seen by our eyes without the Lord’s help.



5. Write the following at the bottom of today’s assignments in your scripture study journal:

*I have studied Doctrine and Covenants 131 and completed this lesson on (date).*

*Additional questions, thoughts, and insights I would like to share with my teacher:*

## UNIT 28: DAY 4

# Doctrine and Covenants 132:1–33

### Introduction

Doctrine and Covenants 132 contains a revelation concerning the new and everlasting covenant of marriage. Although this revelation was recorded on July 12, 1843, some of the truths in the revelation were known and taught by the Prophet Joseph Smith as early as 1831. In this lesson you will learn about the conditions of the new and everlasting covenant of marriage and the promises extended to those who honor it.

### Doctrine and Covenants 132:1–18

*The Lord sets forth the conditions of the new and everlasting covenant*



In Doctrine and Covenants 132:1–2, we read that the Prophet Joseph Smith asked the Lord why Abraham, Isaac, Jacob, and others in the Old Testament had many wives. This question led to the revelation recorded in Doctrine and Covenants 132, which includes instructions about the practice of plural marriage. The Bible and the Book of Mormon teach that God’s standard for marriage is for one man to be married to one woman, unless He declares otherwise (see 2 Samuel 12:7–8; Jacob 2:27, 30). Doctrine and Covenants 132 contains the revelation that established the practice of plural marriage among Church members from the early 1840s until the 1890s, when the Lord revealed that the Saints should no longer enter into plural marriage.

As you study Doctrine and Covenants 132, look for answers to the following questions:

- How will an eternal marriage bless you in this life and forever?
- Why is the marriage covenant in the temple so important?

Read Doctrine and Covenants 132:3–6, looking for the result of entering into the new and everlasting covenant of marriage and the result of rejecting that covenant. The word *damned*, which appears in verses 4 and 6, means that a person is stopped in his or her eternal progression.

According to verse 6, what is a blessing people receive as they abide, or accept, the Lord’s law of marriage?



President Joseph Fielding Smith referred to Doctrine and Covenants 132:7 when he taught about the meaning of “the new and everlasting covenant”: “Now there [in D&C 132:7] is a clear-cut definition in detail of the new and everlasting covenant.

It is everything—the fulness of the gospel. So marriage properly performed, baptism, ordination to the priesthood, everything else—every contract, every obligation, every performance that pertains to the gospel of Jesus Christ, which is sealed by the Holy Spirit of promise according to his law here given, is a part of the new and everlasting covenant” (*Doctrines of Salvation*, comp. Bruce R. McConkie, 3 vols. [1954–56], 1:158).

People often make contracts, or agreements, with each other. Read Doctrine and Covenants 132:7, looking for what happens to man-made contracts when we die. Also look for two conditions that must be in place in order for a covenant to be binding after we die.

From verse 7 we learn the following truth: **When a covenant is made through the proper priesthood authority and is sealed by the Holy Spirit of Promise, it will last forever.**

You might wonder what is meant by the phrase “sealed by the Holy Spirit of promise.” The Guide to the Scriptures provides the following explanation: “The Holy Ghost is the Holy Spirit of Promise (Acts 2:33). He confirms as acceptable to God the righteous acts, ordinances, and covenants of men. The Holy Spirit of Promise witnesses to the Father that the saving ordinances have been performed properly and that the covenants associated with them have been kept” (Guide to the Scriptures, “Holy Spirit of Promise”; scriptures.lds.org).



**1.** Read Doctrine and Covenants 132:15–18, looking for two different ways a man and a woman might enter into a marriage together. Then consider the following examples and, in your scripture study journal, answer the questions according to your understanding of the verses you have read.

- a.** *Example 1:* A man and woman fall in love, keep the law of chastity, and are happily married by a local government leader. They are not sealed in a temple. Their marriage ceremony includes the words “till death do you part.” A few years later, the husband is killed in an accident. According to Doctrine and Covenants 132:15–17, what happens to the marriage when the husband dies?
- b.** *Example 2:* A man and woman are married. They promise one another that they will always love each other and that they will always be together, but they are not sealed in a temple. They believe that because of their love, God will allow them to be together forever. According to Doctrine and Covenants 132:18, what happens to their marriage when one of them dies?

As you consider these examples, remember that we perform ordinances in temples for people who have died without having the opportunity to receive the saving priesthood ordinances. You may have been baptized and confirmed for the dead. Worthy members of the Church who have been endowed can receive the endowment and the sealing ordinances on behalf of people who have died without having received those ordinances themselves.

## Doctrine and Covenants 132:19–33

*The Lord promises blessings to those who obey the law of celestial marriage*



Elder Enrique R. Falabella of the Seventy shared the following experience. As you read it, mark why he and his wife felt sad and why they felt happy.

“When I returned from my mission, I met a beautiful young woman. . . . She captivated me from the first moment I saw her.

“My wife had set the goal to be married in the temple, although back then the nearest temple required a trip of over 4,000 miles (6,400 km).

“Our civil marriage ceremony was both happy and sad, for we were married with an expiration date. The officer pronounced the words, ‘And now I declare you husband and wife,’ but immediately after, he said, ‘until death do you part.’

“So with sacrifice we set out to purchase a one-way ticket to the Mesa Arizona Temple.

“In the temple, as we were kneeling down at the altar, an authorized servant pronounced the words I longed for, which declared us husband and wife for time and for all eternity” (“The Home: The School of Life,” *Ensign* or *Liahona*, May 2013, 102).

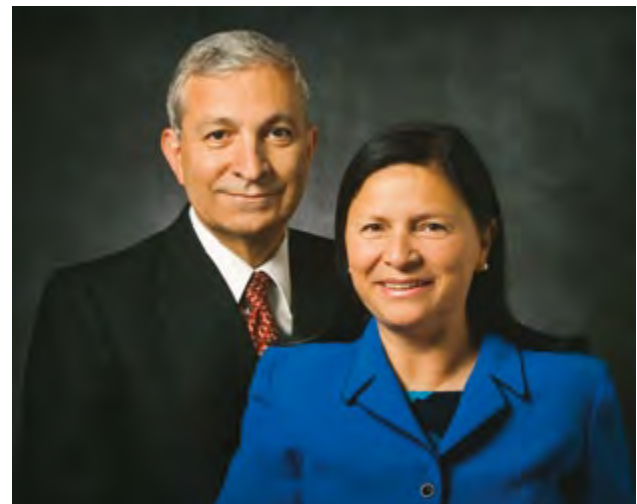



Why were the Falabellas not satisfied with their civil marriage?

 **2.** Study Doctrine and Covenants 132:19–21, looking for blessings the Lord promises to those who are true to the new and everlasting covenant of marriage. In your scripture study journal, write your thoughts about these verses.

As you study these verses, the following information may help you: The word *abide* means to accept or continue, so the phrases “abide in my covenant” (verse 19) and “abide my law” (verse 21) mean to remain true to the Lord’s covenant and law. You may want to mark these phrases.

Doctrine and Covenants 132:19 contains the promise that if a man and woman marry in “the new and everlasting covenant, and it is sealed unto them by the Holy Spirit of promise,” then they “shall come forth in the first resurrection and . . . inherit thrones, kingdoms, principalities, and powers,” as long as they “abide in [the] covenant, and commit no murder whereby to shed innocent blood” (see also D&C 132:27).

The phrases “continuation of the seeds forever and ever” (verse 19) and “they continue” (verse 20) refer to the promise that our families and our posterity can continue throughout eternity.

From Doctrine and Covenants 132:19–21, we learn the following principles:

- **If a man and a woman abide in the new and everlasting covenant of marriage, then they will receive exaltation and glory.**
- **If a man and a woman abide in the new and everlasting covenant of marriage, then they will have an eternal increase of posterity.**
- **If a man and a woman abide in the new and everlasting covenant of marriage, then their marriage will be in force through all eternity.**
- **If a man and a woman abide in the new and everlasting covenant of marriage, then they will become like God.**

Consider the following example. Answer the question according to your understanding of Doctrine and Covenants 132:19–21.



*Example 3:* A young man and a young woman are sealed in a holy temple by priesthood authority. They both live faithfully and keep their covenants. What will happen to their marriage after they die? \_\_\_\_\_

 **3.** Answer the following question in your scripture study journal: What do you think a husband and wife must do to abide in the covenant of marriage? (As you answer this question, think about their relationship with each other as well as their relationship with God.)

Read Doctrine and Covenants 132:22–25, giving special attention to the Lord’s description of the “gate” and the “way” that lead to exaltation. The word *strait* in verse 22 means narrow or exacting, allowing for no wandering off course.



 **4.** In your scripture study journal, draw a picture of the gates and pathways described in Doctrine and Covenants 132:22–25, and then answer the following questions:

- a. In what ways does the image of a broad gate and a wide way represent current opinions in society about couple relationships and marriage?
- b. How are these opinions contrary to the new and everlasting covenant of marriage?

According to verses 22 and 25, many fail to enter the narrow way that leads to exaltation because they fail to accept Jesus Christ and abide by His law, which includes eternal marriage.



From these verses we learn that **to obtain exaltation and eternal lives, we must know Heavenly Father and Jesus Christ, become like Them, and abide in**

**Their law.** In Doctrine and Covenants 132:29–33, we see an example of this principle. We read that Abraham was faithful and obedient to the Lord’s law of eternal marriage and that he received the promise of eternal increase in posterity.

 **5.** Answer the following questions in your scripture study journal:

- a. Why is the law of eternal marriage important to you?
- b. What will you do, beginning today, to prepare yourself to enter the temple and be married for time and all eternity?
- c. What blessings can come in this life to those who obey God’s law to be sealed in the temple?

Prepare now to be worthy to enter the temple and be married for eternity so you can enjoy the blessings that Heavenly Father has prepared for you.

This week you will study Doctrine and Covenants 132:34–66 with your teacher. Those verses address the doctrine of plural marriage. With your teacher, you will discuss the Lord’s standard for marriage today—that “marriage between a man and a woman is ordained of God” (“The Family: A Proclamation to the World,” *Ensign* or *Liahona*, Nov. 2010, 129). You will also discuss the Lord’s command at certain times that some of His people live the law of plural marriage (see Jacob 2:27, 30). You will learn about the Lord’s command to live the law of plural marriage in the latter days, as part of the “restitution of all things” (Acts 3:21), and about His later command to cease that practice (see Official Declaration 1).

 **6.** Write the following at the bottom of today’s assignments in your scripture study journal:

*I have studied Doctrine and Covenants 132:1–33 and completed this lesson on (date).*

*Additional questions, thoughts, and insights I would like to share with my teacher:*

# Doctrine and Covenants 133:1–35

## Introduction

On November 3, 1831, two days after the Lord directed Joseph Smith to publish the Book of Commandments (see D&C 1, section heading), the Prophet received the revelation recorded in Doctrine and Covenants 133. This revelation was included in the 1835 edition of the Doctrine and Covenants as an appendix and was later assigned a section number. Those who were working with the manuscript originally intended the revelation to be a bookend with section 1 to the revelations included in the 1835 edition. Doctrine and Covenants 133 will be covered in two lessons. This lesson covers the Lord’s command that His people prepare themselves and others for His Second Coming. It also covers prophecies of events associated with His Second Coming and millennial reign.

## Doctrine and Covenants 133:1–15

*The Lord commands His people to prepare for His Second Coming*



Have you ever been at school and realized that you have forgotten to prepare for a test? How did you feel, or how do you think you would feel?

How do you feel when you know you have prepared well for a test?

Think about important future events you should prepare for now.

Read Doctrine and Covenants 133:1–3, looking for an event we must prepare for and a reason why.

It may help to know that to “come down upon the world with a curse to judgment” (D&C 133:2) refers to the Lord administering punishment to the wicked at His Second Coming. The phrase “make bare his holy arm” (D&C 133:3) refers to the Lord revealing His strength and power to the world. The phrase “all the ends of the earth shall see the salvation of their God” (D&C 133:3) means that all people will see the deliverance God will bring about for those who follow Him.

As you study Doctrine and Covenants 133, think about why the Second Coming of Jesus Christ and our preparations for it are so important.

According to Doctrine and Covenants 133:2, what will happen to the ungodly, or wicked, at the Second Coming of Jesus Christ? Answer the question by completing the following doctrine with one thing you learn from this verse: **At His Second Coming, Jesus Christ will come** \_\_\_\_\_.

From these verses we learn that the wicked and ungodly will not be prepared for the Second Coming of Jesus Christ. What can we do to make sure we are prepared?



**1.** Complete the following activities in your scripture study journal:

- Write the following phrase: \_\_\_\_\_ *helps prepare us for the Second Coming of Jesus Christ.* Read Doctrine and Covenants 133:4–16, looking for phrases that could be used to fill in the blank. List at least five phrases under the blank in your scripture study journal.
- Select one of the phrases you identified in activity a. Explain why this action is important in preparing us for the Second Coming of Jesus Christ.
- Explain what blessings you will receive now by applying the action you identified in activity b.

Look back at Doctrine and Covenants 133:5, 7, 14. Consider marking the similar phrase you notice in each verse.

In Old Testament times, the city of Babylon was a place of great wickedness. In these verses, Babylon can be seen as a symbol of both wickedness and worldliness.

 **2.** Answer the following questions in your scripture study journal:

- a. What might it mean when the Lord directs us to go out from Babylon?
- b. In what ways can we go out from Babylon? How might these things prepare us for the Second Coming?

Notice what the Lord taught in Doctrine and Covenants 133:15 about how we are to leave Babylon. The Lord is saying that when the Bridegroom comes (see verse 10), there will be no time to hastily get things done that should have been done earlier. This is similar to the message taught in the parable of the ten virgins (see Matthew 25:1–13; see also D&C 45:56–57). Five of the virgins hastily tried to get ready when the announcement was made that the Bridegroom was coming, but it was too late.

Notice also in Doctrine and Covenants 133:15 what the Lord warned us not to do as we go out from Babylon. You might want to mark what you find.



The Lord has commanded us to leave wickedness and not look back.

Ponder what you think it means to “not look back” (D&C 133:15) after we have removed ourselves from sinful and worldly influences. The concept of *not looking back* refers to an attempt to totally forsake wickedness and worldliness and not return to former ways. This verse is a warning to us not to long for and then return to our previous lifestyle.

Consider writing the following truth in the margin of your scriptures next to verse 15: **If we return to any wickedness and former sins, then we will not be prepared for the Savior’s Second Coming.**

 **3.** Answer the following question in your scripture study journal: What can Latter-day Saint youth do to “not look back” as they try to grow spiritually and come closer to the Savior?

Notice in Doctrine and Covenants 133:9 that the Lord directed His people to gather to the physical

location of Zion. Remember that Zion also represents the righteous—those who are pure in heart, united, and dedicated to God’s purposes.

 **4.** Answer the following question in your scripture study journal: What encouragement would you give to someone who has left Babylon (wickedness and worldliness) and is striving to move toward Zion (righteousness) to help him or her remain faithful?

If you were absent the day your teacher announced a major upcoming test, what would you hope a classmate would do for you?

In Doctrine and Covenants 133:4–15, the Lord also taught the Saints that part of their preparation for the Second Coming included helping others prepare as well. What type of work is the Lord describing in verses 8–10?

Addressing his remarks to prospective missionaries, Elder Neil L. Andersen of the Quorum of the Twelve Apostles taught about an important responsibility that also applies to all Church members:



“One of your important responsibilities is to help prepare the world for the Second Coming of the Savior. . . .

“Your mission will be a sacred opportunity to bring others to Christ and help prepare for the Second Coming of the Savior. . . .

“. . . The world is being prepared for the Second Coming of the Savior in large measure because of the Lord’s work through His missionaries” (“Preparing the World for the Second Coming,” *Ensign or Liahona*, May 2011, 49–51).

 **5.** Complete the following assignments in your scripture study journal:

- a. Answer the following questions: How do you think helping others prepare for the Second Coming will help you prepare for it as well? What are some additional blessings you will enjoy in your life by helping others prepare for the Second Coming?
- b. Review what you have written about preparing for the Second Coming of Jesus Christ. Write one thing you feel impressed to do to better prepare yourself or help prepare others for the Second Coming. Write a plan for how you will accomplish this goal.

Reread Doctrine and Covenants 133:16, and identify what will help us be prepared to meet the Lord when He comes. Complete the following principle by

filling in the blank with the word you identify: **As we \_\_\_\_\_, we prepare to meet the Lord.**

-  **6.** Answer the following question in your scripture study journal: How does repenting help prepare us for the Second Coming?

## Doctrine and Covenants 133:17–35

*The Lord reveals some events associated with the Second Coming and His millennial reign*

In Doctrine and Covenants 133:17–35, the Lord announced some of the events associated with His Second Coming and millennial reign on the earth. Read these verses, and consider marking any events that stand out to you. Which events are you most interested in witnessing?



One of the events identified in Doctrine and Covenants 133:21–29 is the return of some of the lost tribes of Israel. Elder Bruce R. McConkie of the Quorum of the Twelve Apostles explained: “The Ten Tribes are to come back like anyone else:

by accepting the Book of Mormon and believing the restored gospel. There cannot be two separate and independent church organizations on earth at one and the same time; at least it cannot be in a day when it is possible to govern the Church from one place. The President of the Church holds the keys whereby the Ten Tribes will be led from the lands of the north to their Palestinian homeland. He, not they, will direct their return” (*A New Witness for the Articles of Faith* [1985], 520–21).

Doctrine and Covenants 133:30–35 describes some of the blessings that the covenant people of the Lord receive that are associated with the Lord’s Second Coming. Because of the promises the Lord made to Ephraim (a son of Joseph) and his tribe, the descendants of Ephraim were to be gathered first in the last days. They have been entrusted with the restored gospel and the priesthood authority and keys that allow them to direct the work of gathering the house of Israel. The Lord’s ultimate goal is to help the whole family of God be crowned with glory and receive all of the blessings made available through the ordinances of the gospel.

By repenting and preparing ourselves and others for the Second Coming of Jesus Christ, we can joyfully look forward to His coming and also enjoy the blessings that come from living righteously now.

-  **7.** Write the following at the bottom of today’s assignments in your scripture study journal:

*I have studied Doctrine and Covenants 133:1–35 and completed this lesson on (date).*

*Additional questions, thoughts, and insights I would like to share with my teacher:*

## UNIT 29: DAY 2

# Doctrine and Covenants 133:36–74

## Introduction

This is the second lesson that covers the revelation recorded in Doctrine and Covenants 133. The Prophet Joseph Smith received this revelation on November 3, 1831. It answers questions that missionaries had about preaching the gospel and the gathering of Israel. It also describes the Lord’s Second Coming and what we need to do to prepare for it.

## Doctrine and Covenants 133:36–40

*The Lord declares that the restored gospel shall be preached to all the world*



-  **1.** In your scripture study journal, write some of your feelings as you ponder the Second Coming of Jesus Christ. Do you feel happy and hopeful about seeing the Savior at the time of His Second Coming? How can our preparation for the Second Coming help us overcome fear?

The Second Coming of Jesus Christ will be a sweet and wonderful experience for some and a terrifying experience for others—depending on their preparation and personal worthiness.



Study Doctrine and Covenants 133:36–39, looking for evidence that the Savior desires all people to be prepared for His Second Coming.

We have a role in helping to prepare the earth for the Second Coming of Jesus Christ. Based on what you learn in Doctrine and Covenants 133:37–38, complete the following truth: **As servants of God, we can help prepare others for the Second Coming by** \_\_\_\_\_.

According to verse 38, we are to proclaim the gospel “with a loud voice.” What do you think this means?  
\_\_\_\_\_  
\_\_\_\_\_

Read Doctrine and Covenants 133:40, looking for another thing the servants of God will be doing before the Second Coming of Jesus Christ. What does this verse suggest about how the righteous feel about the Savior’s coming?

In verse 40, which words indicate the desire of the righteous to see the Lord at His Second Coming? You may want to mark these words in your scriptures.

## Doctrine and Covenants 133:41–56

### *Jesus Christ describes His Second Coming*

Study Doctrine and Covenants 133:41–45, looking for the blessings that will come to those who pray and wait for the Second Coming of Jesus Christ. You may want to mark what you find.

From verse 45, we learn that **the Lord has prepared great blessings for those who wait for Him**. You may want to write this principle in your scriptures.

As you read the following statement by Elder Jeffrey R. Holland of the Quorum of the Twelve Apostles, underline what we need to do to faithfully wait for the Lord:



“We must *never*, in *any* age or circumstance, let fear and the father of fear (Satan himself) divert us from our faith and faithful living. There have *always* been questions about the future. Every young person or every young couple in

every era has had to walk by faith into what has *always* been some uncertainty—starting with Adam and Eve in those first tremulous steps out of the Garden of Eden. But that is all right. This is the plan. It will be okay. Just be faithful. God is in charge. He knows your name and He knows your need. . . .

“God expects you to have enough faith and determination and enough trust in Him to keep moving, keep living, keep rejoicing. In fact, He expects you not simply to *face* the future (that sounds pretty grim and stoic); He expects you to embrace and *shape* the future—to love it and rejoice in it and delight in your opportunities.

“God is anxiously waiting for the chance to answer your prayers and fulfill your dreams, just as He always has. But He can’t if you don’t pray, and He can’t if you don’t dream. In short, He can’t if you don’t believe” (“Terror, Triumph, and a Wedding Feast” [Brigham Young University fireside address, Sept. 12, 2004], 3; speeches.byu.edu).

Ponder the following question: Will all people know who Jesus Christ is at the time of His Second Coming? Read Doctrine and Covenants 133:46–47, looking for an answer to this question.

Read Doctrine and Covenants 133:48–49, looking for a description of what Jesus Christ will look like at the time of His Second Coming.

To understand the symbolism of the Savior’s red clothing, it is helpful to know the meaning of the term “wine-vat” in verse 48. A wine vat is also called a wine press, which is a large basin filled with grapes. People stomped on the grapes, squeezing the juice out so it could be gathered in containers. As people trampled the grapes, the juice typically stained their clothing a deep red color.



Grapes were trampled in a wine vat or wine press.

Study Doctrine and Covenants 133:48–51. From these verses we learn of the Lord’s justice and vengeance at His Second Coming.

In the symbol of the wine-press, the grapes represent the wicked, who will be destroyed at the time of the Savior’s Second Coming. His red clothing can be seen as a symbol of His justice.

Read Doctrine and Covenants 133:52–53, looking for what the righteous will remember and mention at “the year of my redeemed” (D&C 133:52). You may want to mark what you find.

 **2.** In your scripture study journal, write about times when you have felt the Lord’s loving kindness.

Read Doctrine and Covenants 133:54–56, looking for what will happen to the righteous Saints who die before the Second Coming.

### Doctrine and Covenants 133:57–74

*The gospel is sent forth to prepare the earth for the Second Coming of Jesus Christ*

Search Doctrine and Covenants 133:57–62, looking for truths about why the gospel needs to go forth before the Lord’s Second Coming.

As you learn the gospel and live it, you will be prepared for the Second Coming. Doctrine and Covenants 133:62 indicates another blessing you can receive. Refer to this verse to complete the following statement: **Those who \_\_\_\_\_ and sanctify themselves shall be given \_\_\_\_\_.**

You might see a connection between the principle in verse 62 and the principle you identified earlier in verse 45—that the Lord has prepared great blessings for those who wait for Him.

 **3.** Answer the following question in your scripture study journal: How does the principle in verse 62 relate to the principle you identified in verse 45?

In Doctrine and Covenants 133:63–74, we read about consequences for those who will not repent and prepare for the Second Coming. Some of these consequences include being cut off from the Lord and being “delivered over unto darkness” (D&C 133:72).

 **4.** Reread Doctrine and Covenants 133:66–67, 70–71, which contains the Lord’s words to people who do not receive Him. Then, in your scripture study journal, summarize the choices of the people described in these verses.

For those who have had the opportunity to receive the Lord but did not receive Him, the Second Coming will be a time of sadness. But if we accept the Lord’s invitation to receive Him, obey His voice, and believe and receive His servants, the Second Coming will be a glorious day for us.

 **5.** Imagine that the Savior has returned to the earth today. Would you rejoice in His presence with those who have waited for Him? In your scripture study journal, write one thing you will do so the Savior’s Second Coming will be a joyful experience for you.

 **6.** Write the following at the bottom of today’s assignments in your scripture journal:

*I have studied Doctrine and Covenants 133:36–74 and completed this lesson on (date).*

*Additional questions, thoughts, and insights I would like share with my teacher:*

### Identify Connections in the Scriptures

Elder David A. Bednar of the Quorum of the Twelve Apostles taught, “A connection is a relationship or link between ideas, people, things, or events, and the scriptures are full of connections. . . . Prayerfully identifying, learning about, and pondering such connections—the similarities and differences, for example—is a primary source of living water and yields inspired insights and treasures of hidden knowledge” (“A Reservoir of Living Water,” [Brigham Young University fireside address, Feb. 4, 2007], 4; [speeches.byu.edu](http://speeches.byu.edu)). Try using this scripture study skill in your personal study.

## UNIT 29: DAY 3

# Doctrine and Covenants 134

### Introduction

On August 17, 1835, a general assembly of the Church met in Kirtland, Ohio, to consider the proposed contents of the first edition of the Doctrine and Covenants. Because the Prophet Joseph Smith was visiting Saints in Michigan, Oliver Cowdery presided at the assembly. In the meeting, the Saints unanimously voted to include a declaration that Oliver Cowdery had written regarding the beliefs of the Church concerning government and laws.

Doctrine and Covenants 134 contains words and phrases that may be difficult to understand. The following list of definitions may be helpful as you study this section:

*Inviolate* (verse 2): Safe, not violated

*Magistrates* (verses 3, 6): Public officials who administer the law

*Republic* (verse 3): A government in which people elect leaders to represent them

*Sovereign* (verse 3): A supreme ruler, such as a king or queen

*Amenable* (verse 4): Accountable

*Infringe upon* (verse 4): Interfere with, limit, violate

*Prescribing* (verses 4, 6): Establishing

*Dictate* (verse 4): Order people to do things a certain way

*Suppress* (verse 4): Limit, restrict

*Inalienable* (verse 5): Undeniable, cannot be taken away

*Sedition* (verse 5, 7): Rebellion against government leaders

*Deference* (verse 6): Compliance, submission

*Supplanted* (verse 6): Replaced

*Anarchy* (verse 6): Lawlessness—the absence of rules and government or rebellion against rules and government

*Proscribe* (verses 7, 9): Forbid

*Conspiracy* (verse 7): The act of secretly working together to overthrow a government or other organization

*Breach* (verse 8): Break or violate

*Redress* (verse 11): Make something right

*Encroachments* (verse 11): Unlawful intrusions

*Exigency* (verse 11): Urgent need

*Servitude* (verse 12): Bondage, slavery

## Doctrine and Covenants 134:1–4

*The responsibilities of governments are set forth*



 **1.** Imagine that your family is joining with other families to form a new country with a new government. Answer the following questions in your scripture study journal:

- a. What do you think is the purpose of a government?
- b. What are a few of the laws you would establish if you were the leader of the new country?

Review the introduction to this lesson and the section introduction for Doctrine and Covenants 134. Look for the reason the Saints felt they needed to publish a declaration about governments and laws.

Read Doctrine and Covenants 134:1, looking for who instituted the idea of governments. Based on what you learn from this verse, complete the following truth:

**Governments are instituted by \_\_\_\_\_ for the benefit of \_\_\_\_\_.**

From verse 1 we also learn the following truth:

**Government officials are accountable to God to act “for the good and safety of society.”**

 **2.** In your scripture study journal, do the following:

- a. List a few ways government leaders can act “for the good and safety of society.”
- b. Read Doctrine and Covenants 134:2, looking for three rights that governments should protect. List these rights.
- c. Read Doctrine and Covenants 134:4, and record another right that governments should protect.

President Ezra Taft Benson testified of the importance of what he called “mankind’s three great rights.” In his following statement, the phrase “Founding Fathers”

refers to the men who established the government of the United States of America.



“The Declaration of Independence affirmed the Founding Fathers’ belief and trust in God in these words: ‘We hold these Truths to be self-evident, that all Men are created equal, that they are endowed by their Creator with certain inalienable Rights, that among these are Life, Liberty and the Pursuit of Happiness.’

“The Doctrine and Covenants states, ‘We believe that no government can exist in peace, except such laws are framed and held inviolate as will secure to each individual the free exercise of conscience, the right and control of property, and the protection of life’ (D&C 134:2). Life, liberty, property—mankind’s three great rights” (“Our Divine Constitution,” *Ensign*, Nov. 1987, 4).

 **3.** In your scripture study journal, record a few examples of how a government can protect the rights listed in Doctrine and Covenants 134:2. Then read Doctrine and Covenants 134:3, looking for something citizens of some countries can do to ensure that their government leaders will uphold the law.

## Doctrine and Covenants 134:5–6, 8

### *The responsibilities of citizens are set forth*

Imagine you live in a place where the government generally protects the rights of its citizens but has recently enacted a law that you disagree with. Which of the following is an appropriate way to respond? (Circle one.)

- Protest by deciding not to abide by any of the laws of the government.
- Threaten or hurt the government officials who created the law you disagree with.
- Gather others to overthrow the government.
- Legally express your views or concerns, but support and uphold the government by obeying the laws.

Read Doctrine and Covenants 134:5–6, looking for what it teaches about citizens’ responsibilities.

One principle this verse teaches is that **we are to sustain and uphold the government where we live.**

Which article of faith does this principle remind you of? \_\_\_\_\_ (Look in the Articles of Faith in the Pearl of Great Price to check your answer.)

 **4.** Answer the following question in your scripture study journal: Why do you think it is important for citizens to sustain and uphold the government?

According to Doctrine and Covenants 134:6, **God wants us to respect and obey divine laws and human laws.** What do you think we should do when a law of the land goes against our beliefs?

As you think about this question, read the following statement by Elder James E. Talmage of the Quorum of the Twelve Apostles:



“In the case of a conflict between the requirements made by the revealed word of God, and those imposed by the secular law, which of these authorities would the members of the Church be bound to obey?”

In answer, the words of Christ may be applied—it is the duty of the people to render unto Caesar the things that are Caesar’s, and unto God the things that are God’s [see Luke 20:21–25] . . .

“Pending the overruling by [God] in favor of religious liberty, it is the duty of the saints to submit themselves to the laws of their country. Nevertheless, they should use every proper method, as citizens or subjects of their several governments, to secure for themselves and for all men the boon of freedom in religious service. It is not required of them to suffer without protest [the] imposition by lawless persecutors, or through the operation of unjust laws; but their protests should be offered in legal and proper order. The saints have practically demonstrated their acceptance of the doctrine that it is better to suffer evil than to do wrong by purely human opposition to unjust authority” (*The Articles of Faith*, 12th ed. [1924], 422–23).

 **5.** Think about people you know who sustain and uphold their government and the law. In your scripture study journal, write about one or two of them. What have you seen them do to sustain and uphold the government and the law?

In Doctrine and Covenants 134:8, we read that governments have a responsibility to punish those who commit crimes and that citizens have a responsibility to help “in bringing offenders against good laws to punishment.”

 **6.** Write a short paragraph in your scripture study journal describing what you will do to sustain and uphold your government and its laws.



## Doctrine and Covenants 134:7, 9–10, 12

*The relationship between religion and government is described*



President Thomas S. Monson and then United States President Ronald Reagan

In Doctrine and Covenants 134:7, 9–10, 12, we read that governments should establish laws that protect religious observance but should not favor one religion over another. We also read that religious societies have a right to punish their disorderly members by excommunicating them or withdrawing their fellowship from them but that such societies do not have authority to make judgments or inflict punishments that would take their members' property or harm them physically.

## Doctrine and Covenants 134:11

*The right to appeal for help from the government is explained*

According to Doctrine and Covenants 134:11, citizens should be allowed to ask their government for help if they have been wronged. This verse also includes a declaration that citizens are justified in defending themselves and others when there is an urgent need and the government is unable to help.

Think about what you appreciate about your country or community.



**7.** Write the following at the bottom of today's assignments in your scripture journal:

*I have studied Doctrine and Covenants 134 and completed this lesson on (date).*

*Additional questions, thoughts, and insights I would like share with my teacher:*

## UNIT 29: DAY 4

# Doctrine and Covenants 135

## Introduction

On June 27, 1844, the Prophet Joseph Smith and his brother Hyrum, who was the Assistant President and the Patriarch of the Church, were murdered in Carthage, Illinois. The Quorum of the Twelve Apostles approved an announcement of the martyrdom to be included at the end of the 1844 edition of the Doctrine and Covenants, which was almost ready to be published. The announcement drew from the eyewitness accounts of Elders John Taylor and Willard Richards, members of the Quorum of the Twelve. It is now recorded in Doctrine and Covenants 135.

## Doctrine and Covenants 135

*The martyrdom of Joseph and Hyrum Smith is announced*

Read Doctrine and Covenants 135:1. Imagine you are a member of the Church living in Nauvoo, Illinois, in 1844, and think about how you might have felt when you received this tragic news.

Many of the Saints were overwhelmed with grief when they learned of the deaths of Joseph and Hyrum Smith. Reflect on your own feelings and testimony of the Prophet Joseph Smith as you learn about the final days of his life.

Joseph Smith and the Saints lived in relative peace in Illinois for about three years. However, by 1842 they again began to experience opposition. Dissenters within the Church and outside opponents combined their efforts against the Prophet and the Church. Some citizens of Illinois began fearing and despising the political influence of the Saints. Others grew envious of the economic growth of Nauvoo and were critical of the power of Nauvoo's city government and militia. Some started disliking the Saints because of misunderstandings about unique Mormon doctrines and practices, such as plural marriage, some of which had been misrepresented by apostate members of the Church. (See *Church History in the Fulness of Times Student Manual* [Church Educational System manual, 2003], 263–66, 270–71.)

By June 1844, animosity against the Church had greatly intensified. Some citizens in Illinois were discussing forcing the Saints from the state, while others were plotting to kill Joseph Smith. Some of those who were

conspiring against the Prophet and the Church were former members of the Church who had apostatized. On June 7, 1844, William Law, who had served as second counselor in the First Presidency, and other apostates printed the first issue of a newspaper called the *Nauvoo Expositor*. Attempting to inflame the public against the Prophet and the Church, these men used this newspaper to slander Joseph Smith and other Church leaders. Joseph Smith and the Nauvoo city council recognized that the inflammatory newspaper would lead to mob violence against the city. They declared it a public nuisance and ordered that the *Nauvoo Expositor* press be destroyed.



Apostates used the *Nauvoo Expositor* to slander the Prophet Joseph Smith and other Church leaders and inflame the public against the Church.

The contents of the *Nauvoo Expositor*, along with the destruction of the press, caused anti-Mormon hostility to escalate. The owners of the press brought legal charges against Joseph Smith and other city leaders, accusing them of inciting a riot. Joseph Smith was cleared of the charges by Latter-day Saint and

non-Latter-day Saint judges, but this only further angered his enemies. As reports began circulating that mobs were gathering to attack the city of Nauvoo, as mayor, Joseph Smith declared Nauvoo to be under martial law (temporary military rule), and with the direction of Governor Thomas Ford of Illinois, Joseph ordered the Nauvoo Legion to defend the city.

The excitement in the area grew so intense that Governor Ford went to Carthage, the center of government for the region, to neutralize the volatile situation. He wrote to Joseph Smith, saying that only a trial of the Prophet and other leaders before a non-Mormon jury in Carthage would satisfy the people. Governor Ford also promised them complete protection and a fair trial if they came voluntarily. Joseph replied that his life would be in danger on the journey, and he would not come.

During this difficult time and after counseling together, the Prophet felt that if he and Hyrum left Nauvoo and traveled to the West, the Saints in Nauvoo would not be harmed. Acting on this inspiration, Joseph and Hyrum crossed the Mississippi River into Iowa. However, some Church members in Nauvoo doubted the Prophet's plan. A few came to him and accused him of cowardice, saying he was abandoning the Saints and leaving them to face the persecution alone. The Prophet replied, "If my life is of no value to my friends it is of none to myself" (in *History of the Church*, 6:549). After counseling together, Joseph and Hyrum returned to Nauvoo. Early in the morning on June 24, 1844, they left for Carthage.

Read Doctrine and Covenants 135:4, looking for the prophecy Joseph Smith made near Carthage.



**1.** Answer the following questions in your scripture study journal:

- a. What do you think it might have been like for Joseph Smith to leave his family, knowing he would not be coming back to them?
- b. Why do you think the Prophet was "calm as a summer's morning" when he knew he was going "like a lamb to the slaughter"?

The Prophet knew his death would preserve the lives of the Saints.

Read Doctrine and Covenants 135:5, and notice what Hyrum read and marked before leaving for Carthage.



Hyrum Smith read and marked the page in this copy of the Book of Mormon before leaving for Carthage. Notice where the corner of the page had been turned down.

 **2.** Answer the following question in your scripture study journal: Why do you think these verses from the book of Ether (Ether 12:36–38) might have been especially meaningful for Hyrum to read at that time?

On June 25, 1844, Joseph, Hyrum, and other leaders posted bail until a formal trial could be held to address the charge of inciting a riot. However, that evening Joseph and Hyrum were committed to Carthage Jail on the charge of treason, which Joseph and his lawyers protested was illegal because that charge had not been mentioned at their earlier bail hearing and no bail could be posted for treason, requiring them to stay in Carthage and in danger.

On June 26, 1844, Joseph met with Governor Ford in the jail. Governor Ford was contemplating going to Nauvoo, and Joseph asked to go along, feeling he was not safe in Carthage. Governor Ford promised that if he left Carthage he would take Joseph and Hyrum with him. That evening the Prophet bore testimony to the guards of the authenticity of the Book of Mormon and the restoration of the gospel.

On the morning of June 27, 1844, Joseph wrote in a letter to his wife, Emma: “I am very much resigned to my lot, knowing I am justified, and have done the best that could be done. Give my love to the children

and all my friends” (in *History of the Church*, 6:605). Later that day, despite being warned of plans to storm the jail and kill the prisoners, Governor Ford left Carthage to speak to the citizens of Nauvoo. He broke his promise and did not take Joseph and Hyrum with him. Before leaving, Governor Ford placed the Carthage Greys—the most visibly hostile of the militias gathered in Carthage—in charge of guarding the jail and disbanded the other militias.

On the hot and humid afternoon of June 27, Apostles John Taylor and Willard Richards were with Joseph and Hyrum in Carthage Jail. A spirit of foreboding overcame the Prophet and those who were with him as they sat in the jailer’s bedroom on the second floor of the jail. The Prophet asked John Taylor to sing “A Poor Wayfaring Man of Grief” (see *Hymns*, no. 29). If you have access to this hymn (or if you can access [lds.org/music/text/hymns/a-poor-wayfaring-man-of-grief](https://www.lds.org/music/text/hymns/a-poor-wayfaring-man-of-grief)), listen to, sing, or read the words and think about why they would have significance for the Prophet at that moment in his life.

Try to visualize the following events as though you were with the Prophet Joseph Smith in Carthage Jail:



The jailer’s bedroom in Carthage Jail, where the mob attacked the Prophet, his brother Hyrum, John Taylor, and Willard Richards

### Using Music as You Study the Gospel

The hymns of the Church can play a significant role in helping us feel the influence of the Holy Ghost in our gospel learning experience. Listening to, singing, or reading the words of a hymn that is directly related to what is being taught in the scriptures can help us review gospel principles and ponder additional insights.



Shortly after 5:00 p.m. on June 27, 1844, a mob of approximately 150–200 men, with their faces painted to hide their identities, surrounded the jail. The guards provided little resistance as several mobbers rushed up the stairs to the room where the Prophet, his brother Hyrum, and his friends were located.

Joseph and the others pushed against the door to prevent the mob from forcing it open. Someone in the mob fired a shot through the upper panel of the door, striking Hyrum on the left side of his nose. He fell backwards, exclaiming, “I am a dead man!” (in *History of the Church*, 6:617). John Taylor later wrote, “I shall never forget the deep feeling of sympathy and regard manifested in the countenance of Brother Joseph as he drew nigh to Hyrum, and, leaning over him, exclaimed, ‘Oh! my poor, dear brother Hyrum!’” (in B. H. Roberts, *The Rise and Fall of Nauvoo* [1965], 443).

Earlier in the day a visitor had given Joseph a revolver. Acting in defense of everyone in the room, Joseph sprang to the door and reached around the doorframe to shoot the pistol into the hall. Only three of the six chambers fired, wounding three of the mobbers. The mob then forced their guns through the half-closed door, and John Taylor continued to beat the barrels of their guns back with a walking stick.

As the conflict at the doorway increased, John Taylor tried to escape the room through a window. As he attempted to leap out of the window, he was shot in the thigh from the doorway and was also shot by someone outside. He fell to the floor, and while attempting to get under the bed next to the window, was severely wounded by three more shots. Meanwhile, Willard Richards began striking the guns that came through the doorway with his cane.

Joseph Smith then decided to try to escape through a window, a decision Willard Richards believed was made to save his and John Taylor’s lives. As Willard Richards continued to deflect the mob at the door, the Prophet went to the open window and exclaimed: “O Lord, my God!” (in *History of the Church*, 6:618). As he did so bullets from both inside the jail and from the ground below hit the Prophet, who fell from the window, landing on the ground below. The mobbers in the jail rushed outside to assure themselves that Joseph was dead. Although there were no members of the Church nearby, someone yelled, “The Mormons are coming!” and the entire mob fled. (See *History of the Church*, 6:618, 620–21; see also *Church History in the Fulness of Times Student Manual*, 283.)



The window above the well, through which the Prophet Joseph Smith fell

 **3.** Read Doctrine and Covenants 135:3. In your scripture study journal, record any thoughts or feelings you have after reading this account of the martyrdom of Joseph and Hyrum Smith.

Read Doctrine and Covenants 135:2, and notice the description of John Taylor’s and Willard Richards’s fates.

Willard Richards only had his left ear grazed by a bullet, which fulfilled a prophecy Joseph had made more than a year before “that the time would come that the balls would fly around him like hail, and he should see his friends fall on the right and on the left, but that there should not be a hole in his garment” (in *History of the Church*, 6:619).

Note the phrase “to seal the testimony of this book and the Book of Mormon” in Doctrine and Covenants 135:1. In this context, the phrase “to seal” is to permanently establish something, such as a testimony. Consider writing this explanation in your scriptures. You might also want to note the word *martyrdom* in verse 1. A martyr is a person who suffers death as a witness to the truth of his or her beliefs or cause. The word *martyr* comes “from a Greek word meaning ‘witness’” (Bible Dictionary, “Martyr”).





Statues of Joseph and Hyrum Smith in Nauvoo, Illinois

Read Doctrine and Covenants 135:7, looking for what the martyrdom of Joseph and Hyrum Smith is a witness of.

 **4.** Answer the following question in your scripture study journal: How can knowing that **Joseph and Hyrum Smith sealed their witness of the truthfulness of the restored gospel with their lives** influence your testimony of the restored gospel?

 **5.** Write the following at the bottom of today's assignments in your scripture journal:

*I have studied Doctrine and Covenants 135 and completed this lesson on (date).*

*Additional questions, thoughts, and insights I would like share with my teacher:*

## UNIT 30: DAY 1

# Succession in the Presidency

### Introduction

After the martyrdom of the Prophet Joseph Smith on June 27, 1844, many people were confused about who would lead The Church of Jesus Christ of Latter-day Saints. But before his death, the Prophet had prepared for this transfer of leadership by conferring all of the keys and powers of the priesthood upon the Quorum of the Twelve Apostles. When Brigham Young, who was the President of the Quorum of the Twelve Apostles, spoke to the Saints on August 8, 1844, many Church members received a spiritual witness that he had been called and prepared by God to lead the Church.

### Timeline of the Succession in the Presidency after the Martyrdom of Joseph Smith

Date	Event
June 27, 1844	Joseph and Hyrum Smith are martyred in Carthage, Illinois.
June 29, 1844	Public viewing of the bodies of Joseph and Hyrum Smith.
June 27–July 7, 1844	Willard Richards and the injured John Taylor are the only Apostles in Nauvoo, Illinois.
July 8, 1844	Parley P. Pratt returns to Nauvoo and helps Willard Richards and John Taylor keep order in the Church.
August 3, 1844	Sidney Rigdon arrives in Nauvoo from Pittsburg, Pennsylvania.
August 4, 1844	Sidney Rigdon tells a group of Saints that he should be the guardian of the Church and wants a special meeting to be called on August 6 to ratify his appointment. The meeting is actually held on Thursday, August 8.
August 6, 1844	Most of the rest of the Apostles, including Brigham Young, return to Nauvoo from their missions.
August 7, 1844	In the morning, the Apostles and Sidney Rigdon meet together in the home of the injured John Taylor. At an afternoon meeting of the Apostles, high council, and high priests, Sidney Rigdon again claims he should be guardian of the Church. Brigham Young states that he holds the keys and wants to do the Lord's will in the matter.

Timeline of the Succession in the Presidency after the Martyrdom of Joseph Smith	
Date	Event
August 8, 1844	<p>During a 10:00 a.m. meeting, Sidney Rigdon speaks for an hour and a half to thousands of assembled Saints, explaining why he should be guardian of the Church. Brigham Young also speaks and calls for the Saints to gather again for a meeting at 2:00 p.m.</p> <p>Throughout the day, many members of the Church received a witness that the mantle, or authority, of the Prophet Joseph Smith fell upon Brigham Young. During the 2:00 p.m. meeting, the Saints sustain Brigham Young and the Twelve Apostles as the Church's leaders.</p> <p>During both meetings, many Saints witness Brigham Young temporarily appear and sound like the Prophet Joseph Smith.</p>

### After the Martyrdom of the Prophet Joseph Smith, Some People Claim the Right to Lead the Church

Imagine that you found out the President of the Church had passed away last night. Who would become the next President of the Church? How would he be chosen? How are the priesthood keys to preside over the Church passed to the next President of the Church?

After the Prophet Joseph Smith was martyred, the Saints experienced deep sadness, and many Church members were confused about who would lead the Church. During this time various people claimed that they had the right to lead the Church. Among them were Sidney Rigdon, James Strang, and Brigham Young.

As you read the following paragraphs, look for why Sidney Rigdon, who had been a prominent leader in the Church for many years, claimed he should lead the Church:

“Sidney Rigdon, First Counselor in the First Presidency, arrived [in Nauvoo] from Pittsburgh, Pennsylvania, on 3 August 1844. In the year before this time, he had begun taking a course contrary to the counsel of the Prophet Joseph Smith and had become estranged [separated] from the Church. He refused to meet with the three members of the Twelve already in Nauvoo and instead spoke to a large group of the Saints assembled for their Sunday worship service” (*Our Heritage: A Brief History of The Church of Jesus Christ of Latter-day Saints* [1996], 66).

Sidney Rigdon called for a special meeting to be held on Tuesday, August 6, so Church members could choose a guardian for the Church. It appeared as though he tried to hold this meeting so Church members could ratify his position as guardian of the Church before all of the Twelve Apostles would return from their missions to the eastern United States. Some Church leaders felt that Brother Rigdon might be plotting “to take advantage of the situation of the saints” (*History of the Church*, 7:225). Fortunately, because of the efforts of Elder Willard Richards and Elder Parley P. Pratt, the meeting was moved to Thursday August 8, by which time most of the Apostles had returned to Nauvoo.

Brother Rigdon claimed that because he had previously been called and ordained as a spokesman for Joseph Smith, it was his responsibility to “see that the church is governed in a proper manner” (in *History of the Church*, 7:229). He also claimed that he should “be a guardian to the people” and that in fulfilling this responsibility, he was doing what God had commanded him to do (see *History of the Church*, 7:230).

THE FIRST PRESIDENCY

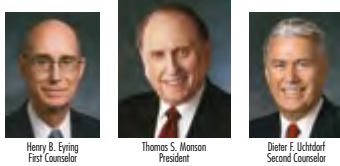

THE QUORUM OF THE TWELVE APOSTLES



The First Presidency and the Quorum of the Twelve Apostles, 2013



Sidney Rigdon

 **1. Answer the following questions in your scripture study journal:**

- a. If you had been in Nauvoo at the time, what might you have thought about Sidney Rigdon's claims?
- b. What concerns might you have had about Brother Rigdon?

As you read the following paragraph, look for why James Strang claimed he should lead the Church:

James Strang, who had been baptized in February 1844, was exploring a possible location for the Saints in Wisconsin in the spring of 1844. After the martyrdom, Brother Strang claimed to have received a revelation in a letter from Joseph Smith stating that he had been appointed to be Joseph's successor. Brother Strang's letter, which he showed to members of the Church, appeared to have Joseph Smith's signature. Brother Strang claimed to be the next prophet and announced his position at a conference of the Church in Michigan on August 5, 1844.

 **2. Answer the following questions in your scripture study journal:**

- a. If you had been with the Saints in Michigan, what, if anything, do you think might have been convincing about James Strang's claims?
- b. What concerns might you have had about his claims?

As you read the following paragraphs, look for what Brigham Young told other priesthood leaders, including the members of the Quorum of the Twelve Apostles who were in Nauvoo, about who should lead the Church:

Elders John Taylor, Willard Richards, and Parley P. Pratt were already in Nauvoo when Sidney Rigdon arrived. Most of the rest of the Apostles, including Brigham Young, returned to Nauvoo on the evening of August 6, 1844. The next day, August 7, the Apostles met in council at the home of John Taylor. Later that day, in an afternoon meeting, the Twelve Apostles, the high council, and the high priests met together in Nauvoo. President Young, President of the Quorum of the Twelve Apostles, asked Sidney Rigdon to state his message to the Saints. Sidney Rigdon boldly declared that he had seen a vision and that no man could succeed Joseph Smith as President of the Church. He then proposed that he be appointed as the guardian of the people.

After Sidney Rigdon concluded his remarks, Brigham Young said:



"I do not care who leads the church, . . . but one thing I must know, and that is what God says about it. I have the keys and the means of obtaining the mind of God on the subject. . . ."

"Joseph conferred upon our heads [referring to the Twelve Apostles] all the keys and powers belonging to the Apostleship which he himself held before he was taken away. . . ."

"How often has Joseph said to the Twelve, 'I have laid the foundation and you must build thereon, for upon your shoulders the kingdom rests'" (in *History of the Church*, 7:230).

 **3. Answer the following questions in your scripture study journal:**

- a. How did President Brigham Young's desires seem to differ from those of Sidney Rigdon and James Strang?
- b. Why was Brigham Young's testimony regarding the keys of the priesthood important?

President Brigham Young and other members of the Quorum of the Twelve Apostles taught the following truth: **The Apostles hold all the keys of the priesthood necessary to preside over the Church.**

Those same powers and keys of the priesthood are held by the Apostles today. When an Apostle is ordained, he is given all of the keys of the priesthood on the earth (see D&C 112:30–32), but the authority to exercise all of those priesthood keys is restricted to the senior Apostle, the President of the Church.



In January 1836, more than eight years before he died, the Prophet Joseph Smith instructed the Quorum of the Twelve Apostles that “the Twelve are not subject to any other than the first Presidency,” and then he said, “Where I am not, there is no First Presidency over the Twelve” (in *History of the Church*, 2:374).

Based on this instruction from the Prophet Joseph Smith, what happens to the First Presidency when the President of the Church dies? \_\_\_\_\_

Who is able to lead the Church when the First Presidency is dissolved? \_\_\_\_\_

Read Doctrine and Covenants 124:127–28, looking for who was the senior Apostle and President of the Quorum of the Twelve Apostles at the time of the Prophet Joseph Smith’s death.

Brigham Young was the President of the Quorum of the Twelve Apostles because he was the senior Apostle. When the quorum was first formed in 1835, seniority was decided by age. As members were added, seniority was determined by the date of ordination. Therefore, in our day, seniority is determined by the date and order in which an Apostle is ordained. **When the President of the Church dies, the First Presidency is dissolved and the Quorum of the Twelve Apostles becomes the presiding quorum, under the direction of the senior Apostle.**

Succession in the Presidency of the Church has been established by the Lord so that the Church is never without inspired leadership, and there is no reason for speculation or controversy over who will become the next President of the Church. President Harold B. Lee explained: “[The Lord] knows whom he wants to preside over this church, and he will make no mistake. The Lord doesn’t do things by accident. He has never done anything accidentally” (in Conference Report, Oct. 1970, 153).

In summary, the keys of the kingdom are conferred upon each member of the Quorum of the Twelve Apostles at the time of his ordination to the apostleship. The senior Apostle, who presides among the Quorum of the Twelve, is determined by the date and order of his ordination. When the President of the Church dies, the Quorum of the First Presidency is dissolved and the counselors, if they previously had been in the Quorum of the Twelve Apostles, return to their respective places of seniority in that quorum. The Quorum of the Twelve Apostles then becomes the presiding quorum in leading the Church. The senior Apostle, as President of the Twelve Apostles, automatically actively holds and exercises all of the priesthood keys of the kingdom and presides over the whole Church. As the presiding officer of the Church, the President of the Quorum of the Twelve has the right to receive revelation regarding when to reorganize the First Presidency. All things in the Lord’s Church are done by wisdom and order.

### **Many Receive a Witness That President Brigham Young Should Lead the Church**

On August 8, 1844, the Saints in Nauvoo, Illinois, gathered at 10 a.m. to hear Sidney Rigdon make his claims as guardian of the Church. Because the wind was blowing toward the stand, Brother Rigdon took his position in a wagon behind the assembled congregation so the people could better hear his voice. The congregation turned around so they could see Brother Rigdon as he preached. He spoke to the thousands of assembled Saints for an hour and a half, explaining why he should be guardian of the Church. Several people described his speech as uninspiring.

President Brigham Young and other Church leaders came and sat on the stand opposite where Sidney Rigdon was speaking. The wind had died down by this point. After Sidney Rigdon had finished, President Young spoke. The audience turned around to hear Brigham speak and turned their backs toward the wagon occupied by Sidney Rigdon. (See “Discourse by President Geo. Q. Cannon,” *Deseret News*, Feb. 21, 1883, 67.) President Young spoke briefly and said that he would have preferred to come back to Nauvoo to mourn for the Prophet than to have to appoint a new leader. He announced that an assembly of Church leaders and members would be held later that day at 2:00 p.m. As he spoke, several Church members saw Brigham Young’s appearance and heard his voice change to resemble those of the Prophet Joseph Smith. This miraculous event helped many of the Saints know that the Lord wanted Brigham Young to lead the Church.



As you read the following experiences, look for how the Lord blessed the Saints to know whom He had appointed to lead the Church. The term “mantle” pertains to authority passing from the prophet and President of the Church (Joseph Smith) to his successor (Brigham Young).

Benjamin F. Johnson recalled, “President Brigham Young arose and spoke. I saw him arise, but as soon as he spoke I jumped upon my feet, for in every possible degree it was Joseph’s voice, and his person, in look, attitude, dress and appearance was Joseph himself, personified; and I knew in a moment the spirit and mantle of Joseph was upon him” (*My Life’s Review* [1947], 103–4).

William C. Staines described Brigham Young as speaking “with the voice like the voice of the Prophet Joseph. I thought it was he, and so did thousands who heard it” (in *History of the Church*, 7:236).



Wilford Woodruff wrote, “If I had not seen him with my own eyes, there is no one that could have convinced me that it was not Joseph Smith, and anyone can testify to this who was acquainted with these two men” (in *History of the Church*, 7:236).

President Brigham Young and other members of the Quorum of the Twelve Apostles spoke during the afternoon meeting. Many others commented that Brigham Young looked and sounded like Joseph Smith as he spoke that day. George Q. Cannon, who was 17 years old in 1844, remembered, “If Joseph had arisen from the dead and again spoken in their hearing, the effect could not have been more startling than it was to many present at that meeting; it was the voice of Joseph himself; and not only was it the vice of Joseph which was heard, but it seemed in the eyes of the people as if it were the very person of Joseph which stood before them. . . . The Lord gave his people a testimony that left no room for doubt as to who was the man chosen to lead them” (in *History of the Church*, 7:236).

In addition to this miracle, many of the Saints also felt the Holy Ghost witness to them that Brigham Young and the Quorum of the Twelve Apostles were called by God to lead the Church. At the conclusion of this meeting, the Saints in Nauvoo voted overwhelmingly to sustain the Quorum of the Twelve Apostles, with Brigham Young at their head, to lead the Church. However, not all Church members ultimately chose to follow the Apostles. Some of the people chose instead to follow individuals such as Sidney Rigdon and James Strang, who formed their own churches.

If you had been at either meeting on August 8, 1844, what conclusions might you have made about whom God had called to lead the Church? \_\_\_\_\_

When the Prophet Joseph Smith died, the senior Apostle (Brigham Young) was immediately able to exercise all of the keys of the priesthood. He had the right to receive revelation concerning when to organize a new First Presidency. In 1847—more than two years after the martyrdom—President Brigham Young was inspired to reorganize the First Presidency rather than continue to lead the Church as President of the Quorum of the Twelve Apostles. As the Church continues to grow and expand, it is important to remember that **through the Holy Ghost, we can receive a witness that those who lead the Church have been called of God.**



The First Presidency, 2013



4. Answer the following questions in your scripture study journal:

- a. Why do you think it is important to receive a testimony that our Church leaders are called of God?
- b. Think about when you have received a witness that a leader of the Church was called of God. If you have had that experience, what did you do to receive that witness? If you have not experienced a witness of Church leaders, write about what you could do to receive one.

 **5.** Ask a member of your family or one of your friends to share with you their experience of receiving a witness from the Holy Ghost that a Church leader was called of God. You might also share what you wrote in the previous journal assignment with them. In your scripture study journal, write what you learned from this person's experience.

 **6.** Write the following at the bottom of today's assignments in your scripture study journal:

*I have studied the "Succession in the Presidency" lesson and completed it on (date).*

*Additional questions, thoughts, and insights I would like to share with my teacher:*

## UNIT 30: DAY 2

# Leaving Nauvoo; the Trek across Iowa; Doctrine and Covenants 136:1–18

### Introduction

After the Prophet Joseph Smith was martyred, the Quorum of the Twelve Apostles, under the direction of Brigham Young, the President of the Quorum of the Twelve, led the Church and carried on the work of the Lord. They encouraged the Saints to complete the Nauvoo Temple and to prepare to move west.

### The Saints Work Diligently to Receive the Blessings of the Temple

Think of a time when you did something difficult because you knew the outcome would be worth the effort.

One of the difficult tasks the Saints were directed to do after the death of the Prophet Joseph Smith was complete the Nauvoo Temple. It took great sacrifice for the Saints to build the Nauvoo Temple. As you read the following paragraph, underline sacrifices the Saints made to build the first temple in Nauvoo:

In the October 1844 general conference, President Brigham Young asked the Saints to give their tithes and offerings to build the temple. In response, Relief Society members each contributed a penny a week for building supplies. Many men tithed their time

by working on the temple one day out of every ten. Others gave more than one-tenth of their means. Joseph Toronto gave Brigham Young \$2,500 in gold and said he wanted to give all that he had to build the kingdom of God.



The original Nauvoo Temple

Why do you think the Saints were willing to sacrifice so much to build the temple?

Even though the Saints sacrificed to build the Nauvoo Temple, persecution made the completion of the temple difficult. Many enemies of the Church thought that once the Prophet Joseph Smith was killed, the Church would collapse. However, when Church members remained faithful and the Church continued to progress, enemies of the Church intensified their efforts to drive the Saints from Illinois.

As you read the following paragraphs, look for what the enemies of the Church did to try to destroy the Church:

In September 1844 Colonel Levi Williams, who had been involved in the murders of Joseph and Hyrum Smith, organized a major military campaign to force the Latter-day Saints out of Illinois. It was advertised as "a great wolf hunt in Hancock County" (David E. Miller and Della S. Miller, *Nauvoo: The City of Joseph* [1974], 186). Upon hearing of this, Governor Thomas

Ford of Illinois sent General John Hardin of the state militia to the county to keep the peace.

A year later, in September 1845, Colonel Williams led a mob of 300 men who raided Latter-day Saints' settlements in outlying areas, burning many unprotected homes, farm buildings, mills, and grain stacks. In mid-September, President Brigham Young asked for volunteers to rescue those Saints. The Saints in Nauvoo prepared 134 wagons to bring the families in the outlying settlements safely to Nauvoo.

How would these attacks have made it difficult to continue working on the temple?

Many residents of Illinois feared that the presence of the Latter-day Saints might lead to a civil war. They asked the Saints to leave the state. On September 24, 1845, the Quorum of the Twelve Apostles promised that the Church would leave the following spring.

Ponder why the decision to leave Illinois might have been a difficult one to make. Also consider how the decision to leave Nauvoo might have affected the Saints' efforts to complete the temple.

Even though the Saints knew they would have to leave Illinois, they continued to build the Nauvoo Temple.



**1.** Answer the following question in your scripture study journal: Why do you think the Saints continued to work on the temple even though they knew they were going to leave?

At that time, temple ordinances necessary for exaltation were not yet available to the general membership of the Church. In an 1841 revelation, the Lord promised the Saints that if they built the Nauvoo Temple, they would be able to receive those saving ordinances (see D&C 124:22–44).

These Saints had faith that temple ordinances would prepare them to abide in the presence of Heavenly Father in eternity and that their families could be eternally sealed together. The accounts of the Saints' sacrifices and difficulties they overcame to build the temple teach us the following truth: **Receiving temple ordinances is worth all our righteous effort and sacrifice.**



**2.** Answer the following questions in your scripture study journal:

- a. Why do you think receiving the ordinances of the temple is worth working hard and making sacrifices?
- b. What do you need to do so you can receive temple ordinances?

Ponder if there is anything you need to stop doing or start doing in order to obtain the blessings of the temple.



President Thomas S. Monson described the sacrifices some modern-day Saints made in order to receive temple ordinances: "Many years ago I read of a group of over a hundred members who left Manaus, [Brazil,] located in the heart of the Amazon rain forest, to travel to what was then the closest temple, located in São Paulo, Brazil—nearly 2,500 miles (4,000 km) from Manaus. Those faithful Saints journeyed by boat for four days on the Amazon River and its tributaries. After completing this journey by water, they boarded buses for another three days of travel—over bumpy roads, with very little to eat, and with nowhere comfortable to sleep. After seven days and nights, they arrived at the temple in São Paulo, where ordinances eternal in nature were performed. Of course their return journey was just as difficult. However, they had received the ordinances and blessings of the temple, and although their purses were empty, they themselves were filled with the spirit of the temple and with gratitude for the blessings they had received" ("The Holy Temple—a Beacon to the World," *Ensign* or *Liahona*, May 2011, 91).

How can these Saints' example inspire you as you prepare to receive temple ordinances?

Read the following paragraphs, and underline examples of the Nauvoo Saints' righteous efforts to receive temple ordinances:

Church leaders dedicated rooms in the Nauvoo Temple as those rooms were completed, so that ordinance work could begin as early as possible. The attic of the temple was dedicated for ordinance work on November 30, 1845. The Saints began receiving their endowments on the evening of December 10, with endowment sessions continuing until 3:00 a.m. on December 11.





President Brigham Young worked tirelessly to provide temple ordinances for the Saints before they were forced to leave Nauvoo, Illinois.

By the end of 1845, over 1,000 members had received temple ordinances. In January 1846, President Brigham Young recorded, “Such has been the anxiety manifested by the saints to receive the ordinances [of the Temple], and such the anxiety on our part to administer to them, that I have given myself up entirely to the work of the Lord in the Temple night and day, not taking more than four hours sleep, upon an average, per day, and going home but once a week” (in *History of the Church*, 7:567). Many Church members contributed by washing the temple clothing each night so the work could continue the next morning without delay.

On February 3, 1846, President Young left the temple to make final preparations to leave Nauvoo the next day on the journey west. However, a large crowd had gathered to receive their endowments, and he compassionately returned to serve them. This delayed his departure for another two weeks. According to temple records, 5,615 Saints were endowed before going west. (See *Church History in the Fulness of Times Student Manual*, 2nd ed. [Church Educational System manual, 2003], 303–4.)



3. Answer the following questions in your scripture study journal:

- a. What impresses you about the Saints’ efforts to receive temple ordinances?
- b. What efforts and sacrifices do we need to make to receive temple ordinances?

### The Saints Leave Nauvoo

After receiving temple ordinances, the Saints began to leave Nauvoo in February 1846. However, not all Church members left with the main body of the Saints. A small number were not prepared in time to leave, and some chose to stay.

Many of the Saints who remained in Nauvoo continued to experience persecution. In September 1846, seven months after the main group of Saints had departed, approximately 800 people, armed with six cannons, prepared to attack Nauvoo. The remaining Saints and some new citizens, numbering only about 150 fighting men, prepared to defend the city.

After a few days of fighting, the Saints were forced to surrender and were told to leave the city immediately. The mob then entered the city, looted homes, and vandalized the temple. Some Saints who were not able to escape fast enough were beaten or thrown into the Mississippi River. After the Saints fled Nauvoo, they set up refugee camps along the western bank of the river. Most people did not have enough food or supplies to sustain themselves.

Church leaders sent rescue parties back across the difficult terrain of Iowa to help the suffering Saints.



4. Answer the following question in your scripture study journal: How do you think you might have felt if you had been called to return to help those suffering Saints?

Read the following message President Brigham Young gave to the men who were charged with recruiting the rescue parties:



“Let the fire of the covenant which you made in the House of the Lord, burn in your hearts, like flame unquenchable, till you . . . have searched out every man . . . who [is able to leave], and impart the fire to his soul, till he shall rise up . . . and go straitway, and bring a load of the poor from Nauvoo. . . .

“. . . This is a day of action” (Journal History of The Church of Jesus Christ of Latter-day Saints, Sept. 28, 1846, 5–6, Church History Library, Salt Lake City).





The temporary settlement of Winter Quarters

Brigham Young’s statement teaches us that **the Lord requires us to live by the covenants we make.**



**5.** Answer the following questions in your scripture study journal:

- a. What sacrifices have you made to keep covenants?
- b. What blessings have you experienced because you have lived according to the covenants you have made?

## The Saints Cross Iowa and Establish Headquarters at Winter Quarters

When the main body of the Saints began leaving Nauvoo in February 1846, they journeyed west across the state of Iowa. “Leaving Nauvoo was an act of faith for the Saints. They departed without knowing exactly where they were going or when they would arrive at a place to settle. They only knew that they were on the verge of being driven out of Illinois by their enemies and that their leaders had received revelation to locate a refuge somewhere in the Rocky Mountains” (*Church History in the Fulness of Times Student Manual*, 309).

As you read the following account of Orson and Catherine Spencer, look for examples of their faith and trust:

“After leaving Nauvoo, [Catherine], ever delicate and frail, sank rapidly under the ever accumulating hardships. The sorrowing husband wrote imploringly to the wife’s parents, asking them to receive her into their home until the Saints should find an abiding place. The answer came, ‘Let her renounce her degrading faith and she can come back, but never until she does.’”

“When the letter was read to her, she asked her husband to get his Bible and to turn to the book of Ruth and read the first chapter, sixteenth and seventeenth verses: ‘Entreat me not to leave thee or to return from following after thee; for whither thou goest I will go, and where thou lodgest I will lodge. Thy people shall be my people and thy God my God’” (*Memoirs of John R. Young: Utah Pioneer 1847* [1920], 17–18). Catherine Spencer died shortly thereafter.

The Saints met with more difficulties as they traveled. Because of excessive rain and insufficient supplies, the Saints spent four months making the 300-mile journey across Iowa. Considering this slow pace, Church leaders decided not to continue west to the Rocky Mountains until the spring of 1847. They counseled the Saints to settle for the winter. One of the largest settlements, Winter Quarters, was located on the west side of the Missouri River, in the present state of Nebraska.

## Doctrine and Covenants 136:1–18

*The Lord counsels the Saints to organize themselves and prepare to continue their journey west*

President Brigham Young received the revelation recorded in Doctrine and Covenants 136 at Winter Quarters in January 1847.

As you study Doctrine and Covenants 136:1–18, notice the Lord’s counsel regarding how the Saints were to organize themselves and prepare to continue their journey west.

You will learn more about the journey west with your teacher in the lesson for this unit.



6. Write the following at the bottom of today's assignments in your scripture study journal:

*I have studied "Leaving Nauvoo," "The Trek across Iowa," and Doctrine and Covenants 136:1–18 and completed this lesson on (date).*

*Additional questions, thoughts, and insights I would like to share with my teacher:*

## UNIT 30: DAY 3

# Doctrine and Covenants 136:19–42

### Introduction

In January 1847, President Brigham Young received the revelation recorded in Doctrine and Covenants 136 at Winter Quarters, Nebraska. This lesson covers Doctrine and Covenants 136:19–42, which includes the Lord's counsel to the Saints about how to act on their journey, offers them reassurance, and directs them to keep all of God's commandments.

### Doctrine and Covenants 136:19–29

*The Lord counsels the Saints on how to act on their journey*

Think of an opportunity you have had to interact with other people in a group. What were some positive aspects of working with others in that group?



Working in groups allows us to help one another, but it can also create challenges.

When the Saints were forced to leave Nauvoo in early 1846 and began traveling west, many were unprepared for the journey. The Saints were initially spread out over many miles, which diminished their ability to help one another. In a revelation President Brigham Young received at Winter Quarters, Nebraska, about one year later, the Lord instructed the Saints to organize themselves so they could help one another as they continued their journey.

Review Doctrine and Covenants 136:2, 8–10, looking for the Lord's instructions on how the Saints were to help one another.

Although working in groups allows us to help one another, it can also create challenges. Ponder about some of the challenges that can occur when working in groups.

Read Doctrine and Covenants 136:19–27, looking for the Lord's counsel for the Saints as they traveled and worked together.



1. Answer the following questions in your scripture study journal.

- What counsel did you read that would help the Saints travel and work together?
- Why do you think this counsel would be helpful?
- How can you apply this counsel as you interact and work with other people?

Review verses 23–24. Note that the Lord counseled the Saints to "cease drunkenness" (D&C 136:24) even though this revelation came after the Saints had received the Word of Wisdom. The Saints progressed gradually in their observance of the Word of Wisdom. When the revelation in Doctrine and Covenants 136 was given, the Latter-day Saints were not prohibited from consuming all alcoholic drinks as we are today.

According to Doctrine and Covenants 136:24, what should our words do for those around us? To answer this question, complete the following principle: **Our words should** \_\_\_\_\_.

Consider marking the phrase that teaches this principle in your scriptures.

It may be helpful to know that to edify means to build someone up spiritually or emotionally.



2. Complete the following assignments in your scripture study journal:

- Answer the following question: Why do you think it would be important for the Saints to use edifying words as they traveled together?
- Describe an experience when you heard someone use words that edified another person.

Consider things you can say that will edify those around you.

As you read the following accounts of the Saints's experiences as they began their journeys westward, think about how you might have felt and why these faithful Saints would have been willing to go through such trials:

Mary Ann Weston Maughan wrote: “We were called to bury two of our company who died this morning of cholera, a man named Brown and a child. There are more sick in camp. Have been in sight of the Platte River all day. Traveled 15 miles, camped on Salt Creek. Soon some of our company came up with another child dead. They buried it at twilight on the bank of the creek. There are more sick. It makes us feel sad thus to bury our friends by the way. Weather very hot” (Mary Ann Weston Maughan journal, 3 vols., June 21, 1850, 2:1, Family History Library, Salt Lake City; spelling, capitalization, and punctuation modernized).

Clarissa Young Spencer (Brigham Young’s daughter) wrote: “One of Father’s most outstanding qualities as a leader was the manner in which he looked after the temporal and social welfare of his people along with guiding them in their spiritual needs. On the great trek across the plains when everyone but the most feeble walked the greater part of the way, the Saints would be gathered around the campfire for evening entertainment, if the weather was at all favorable. There songs would be sung, music played by the fiddlers, and the men and women would forget the weariness of walking fifteen miles or so over a trackless desert while they joined in dancing the quadrille. It was his way of keeping up ‘morale’ before such a word was ever coined” (with Mabel Harmer, *One Who Was Valiant* [1940], 162).

Based on these accounts, how would you describe the experience of some of the Latter-day Saint pioneers?

 **3.** Read Doctrine and Covenants 136:28–29, looking for the counsel contained in these verses. Then, in your scripture study journal, write one principle describing what we should do when we are happy and one principle describing what we should do when we are sorrowful.

Think about times when Heavenly Father has answered your prayers by helping you be happy. Consider sharing an experience with a family member or friend.

Remember to praise and thank the Lord when you are happy and to pray for help when you are sorrowful.

## Doctrine and Covenants 136:30–42

*The Lord reassures the Saints and counsels them to be diligent in keeping all His commandments*

The Saints had endured great trials, and they knew their continuing journey to the West would also be a great challenge.

What do you think helped the Saints remain faithful even under such difficult circumstances?

Read Doctrine and Covenants 136:30–40, looking for doctrines and principles that might have encouraged the Saints.

You might identify some of the following doctrines and principles:

- **We should not fear our enemies, because they are in the Lord’s hands.**
- **Our trials can prepare us to receive the glory God has for us.**
- **If we humble ourselves and call upon God, then the Spirit will enlighten us.**
- **If we are faithful in keeping all the words that the Lord has given us, we will one day behold His glory.**
- **The Lord gives us His word through His prophets.**
- **The Lord can deliver us from our enemies.**

 **4.** Answer the following questions in your scripture study journal:

- a. How do you think these doctrines and principles helped the Saints remain faithful?
- b. How can these doctrines and principles help you remain faithful during your own difficult experiences?

Consider the overall message you think the Saints may have learned from the Lord’s words in Doctrine and Covenants 136:30–40.

Although you identified a variety of doctrines and principles in these verses, the Lord was providing assurance to the Saints that things would work out.

Read Doctrine and Covenants 136:41–42, looking for further reassurance and counsel from the Lord.

Use what you learned from the Lord’s counsel in verse 42 to complete the following principle: **If we are diligent \_\_\_\_\_, then the Lord’s judgments will not come upon us, our faith will be strong, and our enemies ultimately will not triumph over us.**

 **5.** Answer the following question in your scripture study journal: How can this principle help you?

The Saints obeyed the Lord’s commands. The first group of pioneers left Winter Quarters on April 5, 1847. They traveled more than 1,000 miles and arrived in the Salt Lake Valley in late July 1847. On July 24, 1847, as President Brigham Young overlooked the Salt Lake Valley, he received spiritual confirmation that the Saints had found their new home. He was riding in the back of Wilford Woodruff’s wagon at the time because he was sick with a fever.





President Wilford Woodruff gave the following account of President Young viewing the Salt Lake Valley: “When we came . . . into full view of the valley, I turned the side of my carriage around, open to the west, and President Young arose from his bed and took a survey of the country. While gazing upon the scene before us, he was enraptured in vision for several minutes. He had seen the valley before in vision, and upon this occasion he saw the future glory of Zion and of Israel. . . . When the vision had passed, he said, ‘It is enough. This is the right place. Drive on.’ So I drove to the encampment already formed by those who had come along in advance of us” (*Teaching of Presidents of the Church: Wilford Woodruff* [2004], 146).

Why would it have been important for President Brigham Young and the Saints to receive confirmation that the Salt Lake Valley was the right place to settle? Why would it be important for you to have the assurance that you are doing what the Lord wants you to do?

Strive to keep all the commandments, and listen for the Lord’s assurance in your life.



**6.** Write the following at the bottom of today’s assignments in your scripture study journal:

*I have studied Doctrine and Covenants 136:19–42 and completed this lesson on (date).*

*Additional questions, thoughts, and insights I would like to share with my teacher:*

## UNIT 30: DAY 4

# Handcart Pioneers, 1856–60

## Introduction

The Saints who arrived in the Salt Lake Valley in 1847 went to work to develop agricultural and other resources for future emigration. In September 1851, President Brigham Young and his counselors in the First Presidency reiterated the call for all the Saints living in Iowa and around the world to gather in the Salt Lake Valley. Many Latter-day Saints responded to President Young’s call at great sacrifice. Members of the Quorum of the Twelve Apostles were sent to oversee the migration, and in 1852 more Saints traveled the trail to the Salt Lake Valley than in any other year. Additionally, many Saints journeyed to the Salt Lake Valley in handcart companies between 1856 and 1860.

## Saints Obey the Counsel to Gather to the Salt Lake Valley

Imagine that you were asked to travel 1,300 miles (about 2,090 kilometers) on foot while pulling a cart and that you were allowed to bring only 17 pounds (about 7.7 kilograms) of personal belongings. Would you volunteer for this journey?





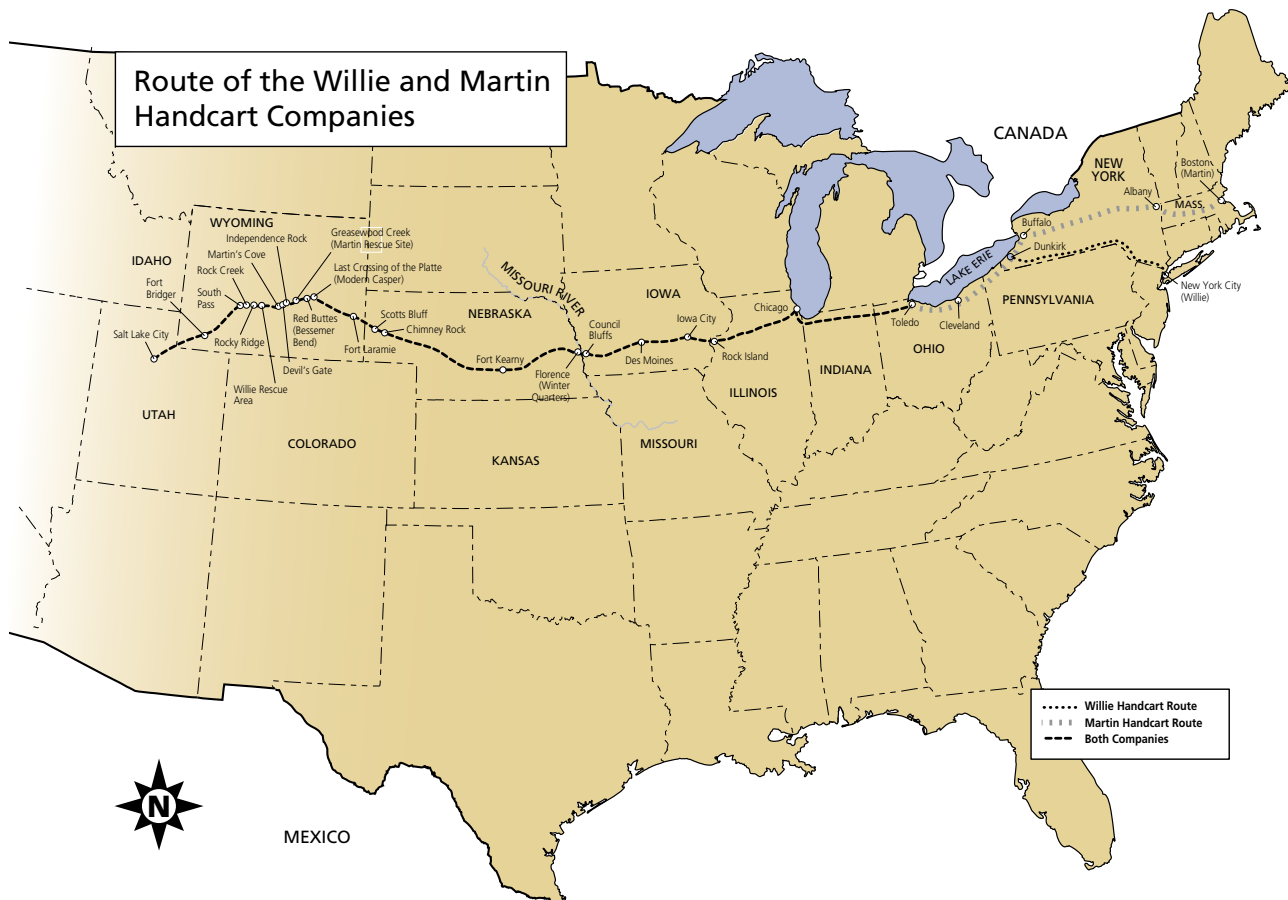

Between 1856 and 1860, almost 3,000 Saints chose to travel west across the plains of the United States to Utah, pulling their belongings in handcarts. Most of the handcart companies loaded provisions, personal items, and some food into handcarts and walked from Iowa City, Iowa, to Salt Lake City, Utah. The last three companies began their journey in Florence, Nebraska.

If possible, gather some items in your home that you would consider taking with you if you had been one of the handcart pioneers. Weigh the items on a scale to get a sense of how much you could take with a 17-pound (about 7.7-kilogram) weight limit.

As you study this lesson, ponder the following question: Why do you think the Saints were willing to sacrifice so much to get to Utah?

Most Church members, including those living outside of the United States, wanted to gather with the Saints in Utah. However, many did not have enough money or supplies to get there. For this reason, President Brigham Young established the Perpetual Emigrating Fund in 1849. The fund gave emigrants a loan to help them pay for travel and supplies. Because of a variety of financial problems, the fund was depleted in 1855, and President Young was concerned that it would

not be sufficient to assist the Saints who wanted to emigrate in 1856. He proposed that emigrants who needed assistance from the fund should travel using handcarts instead of wagons. Handcarts were much less expensive and would allow more of the Saints to emigrate.

Though travel was difficult, 8 of the 10 handcart companies between 1856 and 1860 completed the journey successfully with a mortality rate of about 3 percent, which is comparable to that of a typical wagon company. But in 1856, the fourth and fifth handcart companies started late in the season and experienced severe trials. They were the Willie handcart company, led by James G. Willie, and the Martin handcart company, led by Edward Martin. After traveling almost 1,000 miles (about 1,600 kilometers) west from Iowa, the companies were dangerously low on food and supplies. Both companies were also caught in severe winter storms that halted their progress. These Saints suffered terribly in the extreme cold and snow.

On October 19, 1856, members of the Martin handcart company had to cross a wide river during a winter storm. Many members of the company,

including Aaron Jackson, were weak and sick, and the river crossing took a terrible toll on them. Elizabeth Jackson described what happened to her husband a few days later:

“About nine o’clock I retired. . . . I slept until, as it appeared to me, about midnight. I was extremely cold. The weather was bitter. I listened to hear if my husband breathed—he lay so still. I could not hear him. I became alarmed. I put my hand on his body, when to my horror I discovered that my worst fears were confirmed. My husband was *dead*. . . . I called for help to the other inmates of the tent. They could render me no aid. . . . When daylight came, some of the male part of the company prepared the body for burial. . . . They wrapped him in a blanket and placed him in a pile with thirteen others who had died, and then covered him up in the snow. The ground was frozen so hard that they could not dig a grave” (*Leaves from the Life of Elizabeth Horrocks Jackson Kingsford* [1908], 6–7; see also [history.lds.org](http://history.lds.org)).



 **1.** If you could have written a letter for Elizabeth Jackson to read during this difficult time, what would you have said to encourage her not to give up? Write a short letter to Elizabeth in your scripture study journal.

Look for evidence of Elizabeth’s faith in the rest of her account:

“He was left there to sleep in peace until the trump of the Lord shall sound, and the dead in Christ shall awake and come forth in the morning of the first resurrection. We shall then again unite our hearts and lives and eternity will furnish us with life forever more.

“I will not attempt to describe my feelings at finding myself thus left a widow with three children, under such excruciating circumstances. I cannot do it. But

I believe the Recording Angel has inscribed in the archives above, and that my sufferings for the Gospel’s sake will be sanctified unto me for my good” (*Leaves*, 7; see also [history.lds.org](http://history.lds.org)).

 **2.** Answer the following questions in your scripture study journal:

- a. From Elizabeth’s account, what is one purpose for our suffering and sacrifices for the gospel’s sake?
- b. The phrase “sanctified unto me for my good” means that Elizabeth’s suffering would be made sacred and holy for her benefit. Even though you may not suffer like she did, in what ways might you have to suffer for the gospel’s sake? How might you be blessed through these experiences?

During the next few days after Aaron Jackson died, the Martin company pushed forward about 10 miles (about 16 kilometers). Many people died during this time. One night during this part of the journey, no one had sufficient strength to pitch the tents. Elizabeth Jackson sat on a rock with one of her children in her lap and a child on each side of her. She remained in that position until morning. Elizabeth became discouraged. Then, on the night of October 27, she had an experience that gave her hope of rescue:

“It will be readily perceived that under such adverse circumstances I had become despondent. I was six or seven thousand miles from my native land, in a wild, rocky, mountain country, in a destitute condition, the ground covered with snow, the waters covered with ice, and I with three fatherless children with scarcely nothing to protect them from the merciless storms. When I retired to bed that night, being the 27th of Oct., I had a stunning revelation. In my dream, my husband stood by me and said—‘Cheer up, Elizabeth, deliverance is at hand’ ” (*Leaves*, 8; see also [history.lds.org](http://history.lds.org)).

Elizabeth’s dream was fulfilled. The first of the rescuers from Salt Lake City reached the Martin handcart company the next day.

On October 4, 1856, weeks before the winter storms hit the handcart companies, travelers reported to President Brigham Young that pioneer companies were still on the plains and hundreds of miles away. The next day, in a Sunday service, Brigham Young spoke of saving these handcart pioneers:



“Many of our brethren and sisters are on the plains with hand-carts, and probably many are now 700 miles [about 1,100 kilometers] from this place, and they must be brought here, we must send assistance to them. . . .

“That is my religion; that is the dictation of the Holy Ghost that I possess, it is to save the people. . . . This is the salvation I am now seeking for, to save our brethren that would be apt to perish, or suffer extremely, if we do not send them assistance.

“I shall call upon the Bishops this day, I shall not wait until to-morrow, nor until [the] next day, for 60 good mule teams and 12 or 15 wagons . . . [as well as] 12 tons of flour and 40 good teamsters, besides those that drive the teams. . . .

“I will tell you all that your faith, religion, and profession of religion, will never save one soul of you in the celestial kingdom of our God, unless you carry out just such principles as I am now teaching you. Go and bring in those people now on the plains” (“Remarks,” *Deseret News*, Oct. 15, 1856, 252).

What is one principle that President Brigham Young taught the Saints? \_\_\_\_\_

\_\_\_\_\_

Many men and women responded to the prophet’s invitation to help the suffering Saints. Within two days of President Young’s sermon, men left to find the immigrants, driving wagons loaded with supplies.



**3.** Answer the following questions in your scripture study journal:

- a. How might this rescue effort have been a sacrifice for the Saints in the Salt Lake Valley?
- b. What are some sacrifices we can make to help those with physical needs?
- c. What are some sacrifices we can make to help those with spiritual needs?

On October 21, 1856, the first rescue wagons reached the Willie handcart company. Some of these wagons remained there, but most of them continued on to help the Martin handcart company. On October 23, the Willie company traveled about 15 miles [24 kilometers] through blizzard conditions. The first 3 miles [5 kilometers] included a 600-foot [180-meter] climb up a hill called Rocky Ridge.



President James E. Faust of the First Presidency described the valor of young pioneer children in the Willie company:

“Thirteen members of the Willie Company who perished from cold, exhaustion, and starvation are buried in a common grave at Rock Creek Hollow. . . . Two of those buried at Rock Creek Hollow were heroic children of tender

years: Bodil [Mortensen], age [eleven], from Denmark, and James Kirkwood, age eleven, from Scotland.

“Bodil apparently was assigned to care for some small children as they crossed Rocky Ridge. When they arrived at camp, she must have been sent to gather firewood. She was found frozen to death leaning against the wheel of her handcart, clutching sagebrush.

“Let me tell you of James Kirkwood. James was from Glasgow, Scotland. On the trip west, James was accompanied by his widowed mother and three brothers, one of whom, Thomas, was nineteen and crippled and had to ride in the handcart. James’s primary responsibility on the trek was to care for his little four-year-old brother, Joseph, while his mother and oldest brother, Robert, pulled the cart. As they climbed Rocky Ridge, it was snowing and there was a bitter cold wind blowing. It took the whole company [twenty] hours to travel fifteen miles. When little Joseph became too weary to walk, James, the older brother, had no choice but to carry him. Left behind the main group, James and Joseph made their way slowly to camp. When the two finally arrived at the fireside, James ‘having so faithfully carried out his task, collapsed and died from exposure and over-exertion’ ” (“A Priceless Heritage,” *Ensign*, Nov. 1992, 84–85).



President Thomas S. Monson explained how we could live the principle of helping those in need in our day. As you read what he taught, look for additional ways we can help others today.

“Throughout my years as a General Authority I have emphasized a need for the ‘rescue’ of our brothers and sisters from many different situations which may be depriving them of all the blessings the gospel can provide. Since becoming President of the Church I have felt an increased urgency for us to be engaged in this rescue effort. As faithful members of the Church have reached out with love and understanding, many have returned to full activity and are enjoying added blessings in their lives. There is yet much to do in this regard, and I encourage all to continue to reach out to rescue. Said the Lord, ‘When thou art converted, strengthen thy brethren’ (Luke 22:32)” (“Reach Out to Rescue”; LDS.org).



**4.** In your scripture study journal, write about a time you saw someone help those in spiritual or physical need. How did that person help? In what ways did the service bless both the person and those who were served?

Take a moment to consider who around you may need spiritual or physical help. How can you assist them?

The following account can help you identify some of the blessings these Saints received because they endured their suffering faithfully:

In 1856, Francis and Betsy Webster had enough money to travel to Utah in a wagon, but they donated their money to the Perpetual Emigrating Fund. Their donation allowed an additional nine individuals to travel by handcart. Brother and Sister Webster, who were expecting a baby, traveled to Salt Lake City with the Martin handcart company and suffered along with the rest of the company.

Years later, as Brother Webster sat in a Sunday School class, he listened to some Church members criticize Church leaders for the handcart tragedy. Unable to constrain himself, he arose and testified of the blessings of being in the Martin handcart company:

“I ask you to stop this criticism for you are discussing a matter you know nothing about. Cold historic facts mean nothing here for they give no proper interpretation of the questions involved. Mistake to send the handcart company out so late in the season? Yes. But I was in that company and my wife was in it. . . . We suffered beyond anything you can imagine and many died of exposure and starvation. But did you ever hear a survivor of that company utter a word of criticism? . . . Everyone of us came through with the absolute knowledge that God lives for we became acquainted with him in our extremities [extreme needs].

“I have pulled my handcart when I was so weak and weary from illness and lack of food that I could hardly put one foot ahead of the other. I have looked ahead and seen a patch of sand or a hill slope and I said I can go only that far and there I must give up for I cannot pull my load through it. I have gone on to that sand and when I reached it, the cart began pushing me. I have looked back many times to see who was pushing my cart but my eyes saw no one. I knew then that the angels of God were there.



“Was I sorry that I chose to come by handcart? No. Neither then nor one moment of my life since. The price we paid to become acquainted with God was a privilege to pay and I am thankful that I was privileged to come to Zion in the Martin Handcart Company” (in William R. Palmer, “Pioneers of Southern Utah,” *The Instructor*, May 1944, 217–18).

One principle we can learn from Francis Webster’s testimony is that **if we endure suffering faithfully, we can become acquainted with God.**

 **5.** Answer the following questions in your scripture study journal:

- a. What attitudes or behaviors have you seen in those who have endured suffering faithfully?
- b. In what ways have you become acquainted with God through the trials you have faced?

 **6.** Write the following at the bottom of today’s assignments in your scripture study journal:

*I have studied the “Handcart Pioneers, 1856–60” lesson and completed it on (date).*

*Additional questions, thoughts, and insights I would like to share with my teacher:*



## UNIT 31: DAY 1

# The Utah War and the Mountain Meadows Massacre

### Introduction

During the 1850s, tension and miscommunication between Latter-day Saints and officials of the United States government led to the Utah War of 1857–58. In September 1857, conflict also arose between some Latter-day Saints and members of an emigrant wagon train passing through Utah. Motivated by anger and fear, some Latter-day Saints in southern Utah planned and carried out the massacre of about 120 emigrants traveling to California. This atrocity is now known as the Mountain Meadows Massacre. For more information, go to [LDS.org](https://www.latterdaymovement.org), select **Gospel Topics**, and search for **Mountain Meadows Massacre**.

### Tension Builds between Latter-day Saints and the United States Government

On July 24, 1857, President Brigham Young was with a group of Saints celebrating the 10th anniversary of their arrival in the Salt Lake Valley when they

received confirmation of earlier news that an army commissioned by the United States government was coming to Salt Lake City. In previous years, disagreements and miscommunication had resulted in growing tension between the Latter-day Saints and officials of the United States government. The Saints wanted to be governed by leaders of their own choosing and had rejected federal appointees who did not share their values. That led some federal officials to consider them in rebellion against the United States government. Without approval from Congress, United States President James Buchanan sent approximately 1,500 troops to Salt Lake City to force Utahns to accept new officials.

If you had been a Latter-day Saint in 1857 and heard that a large army was approaching your city, what concerns might you have had? Remember that memories of being violently driven from Ohio, Missouri, and Illinois were still fresh in the minds of many of the Latter-day Saints. Many had lost valued possessions and land, and some Church members had been killed or had died from causes related to these persecutions. News of the approaching army produced concerns that such events might also occur in Utah.

In sermons to the Saints, President Young and other Church leaders described the coming troops as enemies. President Young, who for years had asked the Saints to save grain, renewed his instructions so they would have food to eat if they needed to flee from the troops. As

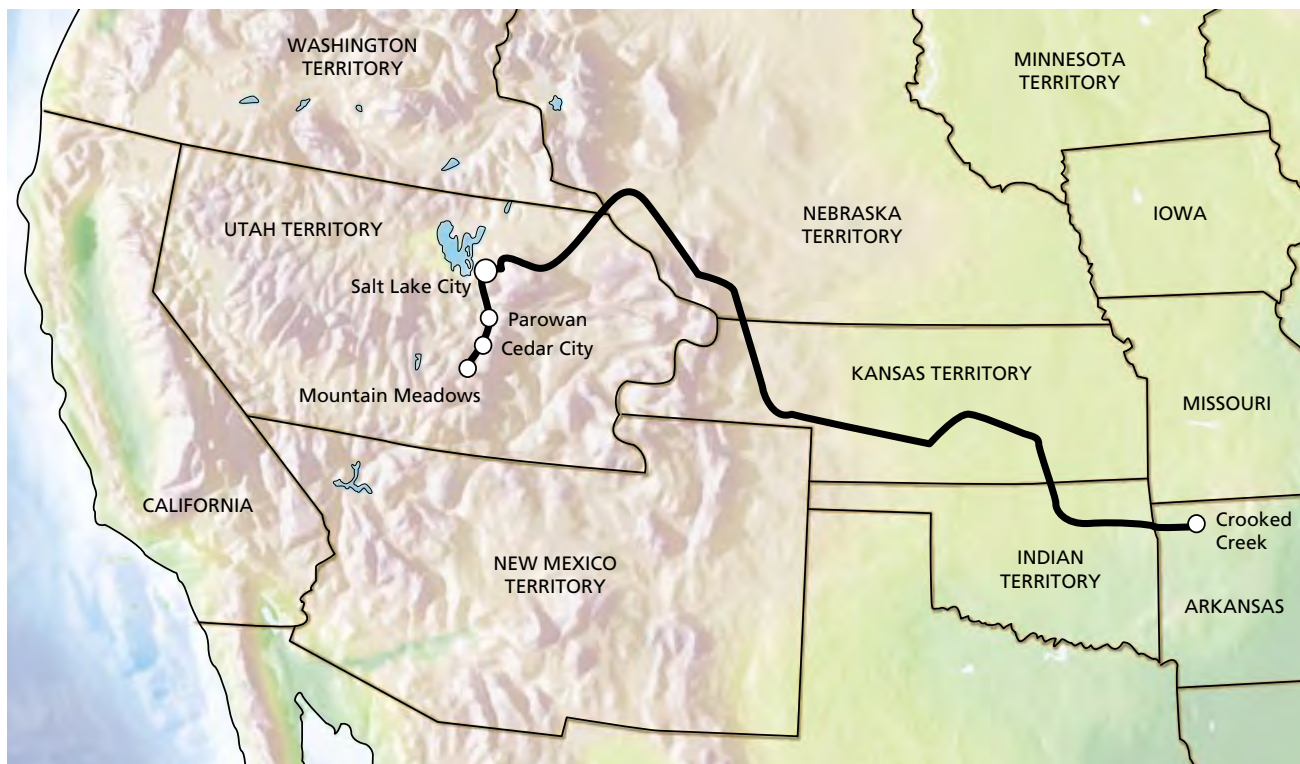

governor of Utah Territory, he also directed the territory's militia to prepare to defend the territory. (A militia is a group of citizens who can be organized for military service in emergencies.)

## Conflict Arises between Some Latter-day Saints and Members of an Emigrant Wagon Train

An emigrant wagon train traveling west from Arkansas to California entered Utah just as Latter-day Saints were preparing to defend the territory against the coming United States troops. As you read the following paragraphs, underline reasons for the hard feelings between some members of the wagon train and some of the Latter-day Saints.

Some members of the wagon train became frustrated because they had a difficult time purchasing much-needed supplies and grain from the Saints, who had been instructed to save their grain. The emigrants also came into conflict with Saints who did not want the wagon train's horses and cattle to consume food and water resources the Saints needed for their own animals.

Tensions erupted in Cedar City, the last settlement in Utah on the route to California. Confrontations occurred between some members of the wagon train and some of the Latter-day Saints. Some members of the wagon train threatened to join the incoming government troops against the Saints. Even though the captain of the wagon train rebuked his companions for making these threats, some Cedar City leaders and settlers viewed the emigrants as enemies. The wagon company left town only about an hour after it arrived, but some of the settlers and leaders in Cedar City wanted to pursue and punish the men who had offended them.

Think about times when you have experienced conflict with another person or a group of people. Read 3 Nephi 12:25, looking for a principle Jesus Christ taught that can guide us when we experience tension with others.



What do you think it means to “agree with thine adversary quickly”? Elder David E. Sorensen of the Seventy taught that the phrase means to “resolve our differences early on, lest the passions of the moment escalate into physical or emotional cruelty, and we fall captive to our anger” (“Forgiveness Will Change Bitterness to Love,” *Ensign* or *Liahona*, May 2003, 11).

Based on the Lord's teachings in 3 Nephi 12:25 and Elder Sorensen's explanation, we learn that **if we resolve conflict with others in the Lord's way, then we can avoid the harmful effects of contention.**



1. Answer the following questions in your scripture study journal:

- How might obeying the principle in 3 Nephi 12:25 have helped the Latter-day Saints who had become upset with members of the wagon train?
- How has seeking to resolve differences in the Lord's way helped you or someone you know avoid the harmful effects of contention?

Because some of the settlers of Cedar City did not resolve their conflict with the emigrants in the Lord's way, the situation became much more serious. As you continue to study, consider the dangers of acting out of anger or revenge.

Isaac Haight, the Cedar City mayor, militia major, and stake president, requested permission from the militia commander, who lived in the nearby settlement of Parowan, to call out the militia to confront the offenders from the wagon train. The militia commander, William Dame, counseled Isaac Haight to ignore the emigrants' threats. Instead of following this counsel, Isaac Haight and other Cedar City leaders decided to persuade some local Indians to attack the wagon train and steal their cattle as a way of punishing the emigrants. Isaac Haight asked John D. Lee, a local Church member and militia major, to lead this attack, and the two planned to blame Indians for the deed.

What should the Cedar City leaders have done when William Dame counseled them not to use the militia? What did rejecting counsel then lead them to do?

One principle we learn from the example of these Cedar City leaders is that **if we ignore counsel to do what is right, then we become more susceptible to making poor choices.** Watch for evidence of this principle as you continue to learn about the actions of these leaders. As you read the following paragraphs, underline ways in which Cedar City leaders continued to make poor choices after ignoring the counsel they had received:

Isaac Haight presented the plan to attack the wagon train to a council of local leaders in the Church, community, and militia. Some council members strongly disagreed with the plan and asked Haight if he had consulted with President Brigham Young about the matter. Saying he had not, Haight agreed to send a messenger, James Haslam, to Salt Lake City with a letter explaining the situation and asking what should be done. However, because Salt Lake City is

approximately 250 miles (about 400 kilometers) from Cedar City, it would require about a week of hard riding on horseback for the messenger to reach Salt Lake City and return to Cedar City with President Young's instructions.

Shortly before Isaac Haight sent his letter with the messenger, John D. Lee and a group of Indians attacked the emigrant camp at a place called the Mountain Meadows. Lee led the attack but concealed his identity so that it would appear that only the Indians were involved. Some of the emigrants were killed or wounded, but the remainder fought off their attackers, forcing Lee and the Indians to retreat. The emigrants quickly pulled their wagons into a tight circle, or corral, for protection. Two additional attacks followed during a five-day siege upon the wagon train.



At one point, Cedar City militiamen became aware of two emigrant men who were outside the wagon corral. The militiamen fired on them, killing one. The other man escaped and brought news to the wagon camp that white men were involved in the attacks against them. Those who planned the attacks were now caught in their deception. If the emigrants were allowed to go on to California, news would spread that Latter-day Saints were responsible for the attack on the wagon train. The conspirators feared this news would bring negative consequences upon themselves and their people.



**2.** Answer the following questions in your scripture study journal:

- a. At this point, what choices were available to those responsible for the attacks upon the emigrants?
- b. What should they have done? Why?

In making their poor choices, these men acted contrary to their priesthood responsibilities. Read Doctrine and Covenants 121:36–37, and mark the Lord's warning to priesthood holders who act unrighteously.

Think about what you do after you have done something wrong. Do you confess what you have done wrong and receive the consequences, or do you try to hide the sin through deception?

### Some Latter-day Saints Plan and Carry Out the Mountain Meadows Massacre

The Church members involved in the attacks against the emigrants chose to try to hide their sins. In an attempt to prevent news from spreading that Latter-day Saints were involved in the attacks on the wagon train, Isaac Haight, John D. Lee, and other local Church and militia leaders made a plan to kill all the remaining emigrants except for small children. Enacting this plan, John D. Lee approached the emigrants and said the militia would protect them from further attacks by guiding them safely back to Cedar City. As the emigrants were walking toward Cedar City, the militiamen turned and fired on them. Some Indians rushed from hiding places to join the attack. Of approximately 140 emigrants who were part of the wagon train, only 17 young children were spared.



The monument memorializing the tragedy at Mountain Meadows

Two days after the massacre, James Haslam arrived in Cedar City with President Young's message of reply instructing the local leaders to allow the wagon train to go in peace. "When Haight read Young's words, he sobbed like a child and could manage only the words, 'Too late, too late'" (Richard E. Turley Jr., "The Mountain Meadows Massacre," *Ensign*, Sep. 2007, 20).



The choices of some Latter-day Saint leaders and settlers in southern Utah Territory led to the tragic Mountain Meadows Massacre. In contrast, Church and territory leaders in Salt Lake City resolved the conflict with the United States government through peace talks and negotiation in 1858. During this conflict—later called the Utah War—the United States troops and Utah militiamen engaged in acts of aggression but never in battle.



Speaking of the Mountain Meadows Massacre, President Henry B. Eyring of the First Presidency said: “The gospel of Jesus Christ that we espouse, abhors the cold-blooded killing of men, women, and children. Indeed, it advocates peace and forgiveness. What was done [at the Mountain Meadows] long ago by members of our Church represents a terrible and inexcusable departure from Christian teaching and conduct” (“150th Anniversary of Mountain Meadows Massacre,” Sept. 11, 2007, [mormonnewsroom.org/article/150th-anniversary-of-mountain-meadows-massacre](http://mormonnewsroom.org/article/150th-anniversary-of-mountain-meadows-massacre)).

The Mountain Meadows Massacre not only resulted in the deaths of about 120 victims, but it also caused great suffering to the surviving children and other relatives of the victims. Paiute Indians also suffered from being unjustly blamed for the crime. In addition, some of those “who carried out the massacre labored the rest of their lives under a horrible sense of guilt and recurring nightmares of what they had done and seen” (Richard E. Turley Jr., “The Mountain Meadows Massacre,” 20).

 **3.** Complete the following assignments in your scripture study journal:

- a. Summarize the mistakes that led to the Mountain Meadows Massacre.
- b. Write a principle or lesson we can learn from this tragedy about choosing to hide our sins.
- c. Answer the following questions: What can you do in the future to make sure you follow your leaders’ counsel and avoid covering up sins you might commit? What blessings can you experience from taking responsibility for your mistakes and not trying to hide your sins?

If you have started down a pathway of mistakes and sins, you can prevent future heartache and regret by turning to the Lord now and repenting of your sins.

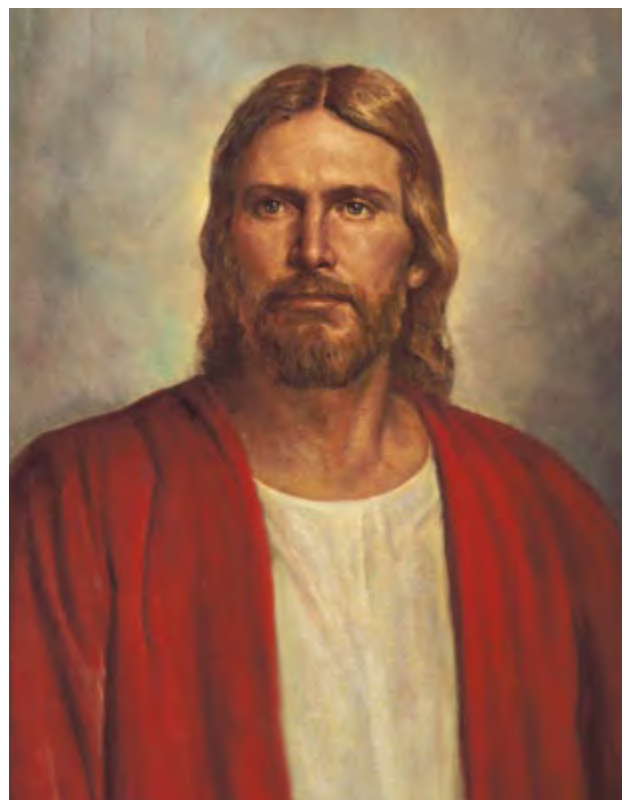

Because some of the local Latter-day Saints were responsible for planning and carrying out the Mountain Meadows Massacre, some people have allowed this event to negatively affect their view of the Church. Something similar occurred in the Book of Mormon when Alma’s missionary son violated the law of chastity and others would not believe Alma’s words because of the conduct of his son (see Alma 39:11).

 **4.** Answer the following question in your scripture study journal: Why is it important to realize that the wrong actions of some Church members do not determine the truthfulness of the gospel?

Read Helaman 5:12, looking for what we can do to develop and maintain our testimonies so that during difficult times, such as when we learn of instances when Church members have failed to live according to the teachings of Jesus Christ, our faith will not be shaken. Summarize what you find: \_\_\_\_\_

\_\_\_\_\_

One principle we can learn from Helaman 5:12 is that **we can develop strong testimonies by building our faith on the foundation of Jesus Christ.**



The following example illustrates this principle: “James Sanders is the great-grandson of . . . one of the children who survived the massacre [and is also a member of the Church]. ‘I still feel pain; I still feel anger and sadness that the massacre happened,’ said Brother Sanders. ‘But I know that the people who did this will be accountable before the Lord, and that brings me peace.’ [He] said that learning his ancestor had been killed in the massacre ‘didn’t affect my faith because it’s based on Jesus Christ, not on any person in the Church’” (Richard E. Turley Jr., “The Mountain Meadows Massacre,” 21).



**5.** Answer the following questions in your scripture study journal:

- How can our faith in Jesus Christ strengthen us when we learn of instances when Church members have failed to live according to the Savior’s teachings?
- What are some things you do that help you to build your faith on the foundation of Jesus Christ?
- What is one thing that you will do this week to better build your faith on the foundation of Jesus Christ? (You may write more than one thing you will do.)



**6.** Write the following at the bottom of today’s assignments in your scripture study journal:

*I have studied “The Utah War and the Mountain Meadows Massacre” lesson and completed it on (date).*

*Additional questions, thoughts, and insights I would like to share with my teacher:*

## UNIT 31: DAY 2

# The Coming Forth of the Pearl of Great Price

## Introduction

In 1851, Elder Franklin D. Richards, a member of the Quorum of the Twelve Apostles and the president of the British Mission, published several revelations, translations, and writings of the Prophet Joseph Smith and called the collection the Pearl of Great Price, which

was later added to the standard works. “The Pearl of Great Price is a selection of choice materials touching many significant aspects of the faith and doctrine of The Church of Jesus Christ of Latter-day Saints” (introduction to the Pearl of Great Price). The phrase “pearl of great price” comes from one of Jesus Christ’s parables (see Matthew 13:45–46). In this parable a merchant sells all he owns to obtain a valuable pearl.

## The Coming Forth of the Pearl of Great Price

Do you know how pearls are made? A pearl is produced inside an oyster as the oyster responds to the irritation of foreign matter, such as a grain of sand. The oyster produces a substance to surround the



grain, and this eventually forms a pearl. Natural pearls are rare and are considered precious.

In this lesson you will learn about the origin of another pearl—the book of scripture titled the Pearl of Great Price. As you study how this book came forth, look for some reasons the Pearl of Great Price is precious to us.

Read the first paragraph in the introduction to the Pearl of Great Price, looking for what is contained in the Pearl of Great Price. The word *periodicals* refers to newspapers or magazines—publications that are distributed periodically, such as daily, weekly, or monthly.

In the second paragraph of the introduction, we learn that in 1851, Elder Franklin D. Richards of the Quorum of the Twelve Apostles compiled a collection of materials from the Prophet Joseph Smith and published them as the Pearl of Great Price. Before materials can become part of the standard works, the First Presidency must approve them and present them to the Church in a general conference for a sustaining vote. During a general conference of the Church in October 1880, the Church accepted the Pearl of Great Price as scripture—part of the standard works.

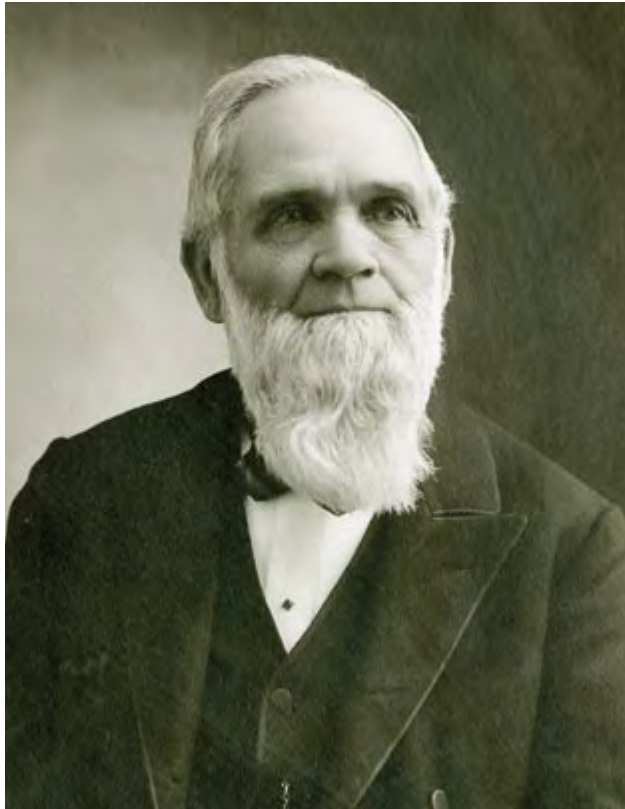

Elder Franklin D. Richards

In the third paragraph of the introduction, we learn that since the first printing of the Pearl of Great Price, some content has been added or moved. Some of its content was added and later moved to the Doctrine and Covenants.

Read the rest of the introduction, and identify the present contents of the Pearl of Great Price.

### The Book of Moses and Joseph Smith—Matthew

The book of Moses and Joseph Smith—Matthew are part of the Joseph Smith Translation of the Bible. The Joseph Smith Translation is “a revision or translation of the King James Version of the Bible in English, which the Prophet Joseph Smith began in June 1830. He was commanded by God to make the translation and regarded it as part of his calling as a prophet” (Guide to the Scriptures, “Joseph Smith Translation”; scriptures.lds.org). The Lord revealed the text of the book of Moses to Joseph Smith as Joseph made additions, changes, and deletions to the first several chapters of Genesis during his translation of the Bible. The book of Moses contains precious truths concerning Heavenly Father’s plan of salvation.



1. Scan the book of Moses, and find at least one verse that contains a truth you consider precious. Write the verse you selected in your scripture study journal, and write why it is meaningful to you.

### The Book of Abraham

Like the book of Moses, the book of Abraham restores precious truths. It teaches about our premortal life and provides greater understanding concerning the life and ministry of Abraham and the covenant the Lord made with him. It is a treasure to have the book of Abraham and see how he honored God at all times and how God honored him.

The following is a description of how the Prophet Joseph Smith obtained the ancient writings in the book of Abraham: “On 3 July 1835 a man named Michael Chandler brought four Egyptian mummies and several papyrus scrolls of ancient Egyptian writings to Kirtland, Ohio. The mummies and papyri had been discovered in Egypt several years earlier by Antonio Lebolo. Kirtland was one of many stops in the eastern United States for Chandler’s mummy exhibition. Chandler was offering the mummies and rolls of papyrus for sale and, at the urging of the Prophet Joseph Smith, several members of the Church donated money to purchase them. In a statement dated 5 July 1835, Joseph Smith, declaring the importance of these ancient Egyptian writings, recorded: ‘I commenced the translation of some of the characters or hieroglyphics, and much to our joy found that one of the rolls contained the writings of Abraham. . . . Truly we can say, the Lord is beginning to reveal the abundance of peace and truth’ (*History of the Church*, 2:236).” (*The Pearl of Great Price Student Manual* [Church Educational System manual, 2000], 28).



Some have wondered how the Prophet translated the ancient writings. Joseph Smith never communicated his method of translating these records, but he translated these writings by the gift and power of God. The Church, scholars, and historians continue to seek to better understand the origins of this book. As with all other scriptures, the greatest means of gaining a testimony of the truthfulness of the book of Abraham

is through prayerful study of the book itself. For more information, go to LDS.org, select **Gospel Topics**, and search for **book of Abraham**.

 **2.** In your scripture journal, answer the following question: Why is it important to obtain a spiritual witness of the truthfulness of the book of Abraham?

The following is a list of commonly asked questions with their accompanying answers about the coming forth of the book of Abraham:

**Question:** Why did Joseph Smith say he had translated the writings of Abraham even though the manuscripts do not date from Abraham's time?

**Answer:** The Prophet Joseph Smith said the book of Abraham was "a translation of some ancient Records that have fallen into our hands, from the Catacombs of Egypt, purporting to be the writings of Abraham, while he was in Egypt" (*Times and Seasons*, Mar. 1, 1842, 704).



Fragment of papyrus of facsimile 1

In 1966, 11 fragments of papyri the Prophet Joseph Smith once had were discovered in the Metropolitan Museum of Art in New York City. These papyri contain authentic Egyptian writings, but they do not date to the time of Abraham, nor do they contain the actual personally handwritten account of Abraham. It is important to remember that only a few fragments and not all of the papyri that Joseph Smith possessed have been found. The book of Abraham may have been translated from papyri that have not been recovered. These lost papyri may have contained copies of Abraham's writings.

At the present time we simply do not know the exact nature of the relationship between the book of Abraham and the papyri Joseph Smith possessed. There are various theories proposed as to how the prophet translated these writings, but we simply do not know the details. We do know that the Prophet

Joseph Smith translated the book of Abraham by the gift and power of God.

**Question:** What did Joseph Smith do with his translation?

**Answer:** "The book of Abraham was originally published a few excerpts at a time in *Times and Seasons*, a Church publication, beginning in March 1842 at Nauvoo, Illinois [see the introduction to the Pearl of Great Price]. The Prophet Joseph Smith indicated that he would publish more of the book of Abraham later, but he was martyred before he was able to do so. Concerning the potential length of the completed translation, Oliver Cowdery once said that 'volumes' would be necessary to contain it (see *Messenger and Advocate*, Dec. 1835, 236).

"In addition to hieroglyphic writings, the manuscript also contained Egyptian drawings. On 23 February 1842, the Prophet Joseph Smith asked Reuben Hedlock, a professional wood engraver and member of the Church, to prepare woodcuts of three of those drawings so they could be printed. Hedlock finished the engravings in one week, and Joseph Smith published the copies (facsimiles) along with the book of Abraham. Joseph Smith's explanations of the drawings accompany the facsimiles" (*The Pearl of Great Price Student Manual*, 28–29).



Woodcuts were made for printing the facsimiles in the book of Abraham



**Question:** What happened to the mummies and the papyri?

**Answer:** “After the death of the Prophet Joseph Smith, the four mummies and the papyri became the property of Joseph’s widowed mother, Lucy Mack Smith. At Lucy’s death in 1856, Emma Smith, the Prophet’s wife, sold the collection to Mr. A. Combs. Several theories have been offered regarding what happened subsequently to the mummies and the papyri. It appears that at least two of the mummies were burned in the great Chicago fire of 1871 (see B. H. Roberts, *New Witnesses for God*, 3 vols. [1909–11], 2:380–382).

“In the early spring of 1966, Dr. Aziz S. Atiya, a University of Utah professor, discovered several fragments of the book of Abraham papyri while doing research at the Metropolitan Museum of Art in New York City. These fragments were presented to the Church by the director of the museum on 27 November 1967. The current whereabouts of the other mummies and the other portions of the papyri are unknown (see H. Donl Peterson, “Some Joseph Smith Papyri Rediscovered (1967)” in *Studies in Scripture, Volume Two*, 183–85)” (*The Pearl of Great Price Student Manual*, 29).

In addition to teaching valuable doctrine and principles, **the Pearl of Great Price is evidence that Joseph Smith was a prophet of God.**

 **3.** Answer the following question in your scripture study journal: In what ways do you think the Pearl of Great Price is evidence of Joseph Smith’s calling as a prophet?

## The Articles of Faith

On March 1, 1842, the Prophet Joseph Smith published a letter he had written to John Wentworth, a newspaper editor, explaining the history and beliefs of the Church. This is commonly known as the Wentworth Letter. In it, Joseph declared 13 fundamental principles of the gospel. These beliefs have been included in the Pearl of Great Price as the Articles of Faith. Although they are not a statement of all of our beliefs, they are an important set of doctrines and principles.

Locate and read the Articles of Faith in the Pearl of Great Price.

 **4.** Choose two articles of faith. In your scripture study journal, complete the following activities for each:

- Write in your own words the doctrine or principle the article of faith teaches.
- Find a scripture that supports or explains the doctrine or principle in the article of faith. Write insights the scripture adds to your understanding of this doctrine or principle.
- List a way that understanding and believing this article of faith might bring blessings into someone’s life.

Elder L. Tom Perry of the Quorum of the Twelve Apostles related how knowledge of the Articles of Faith could be particularly helpful to members of the Church:



“I reached the conclusion that if I studied the content of each of the Articles of Faith, I could explain and defend every gospel principle I might have the opportunity to expound to someone searching for the restored truth.

“What a great blessing it would be if every member of the Church memorized the Articles of Faith and became knowledgeable about the principles contained in each. We would be better prepared to share the gospel with others. . . .

“The Articles of Faith were not the work of a team of scholars but were authored by a single, inspired man who declared comprehensively and concisely the essential doctrines of the gospel of Jesus Christ. They contain direct and simple statements of the principles of our religion, and they constitute strong evidence of the divine inspiration that rested upon the Prophet Joseph Smith” (“The Articles of Faith,” *Ensign*, May 1998, 23–24).

### Practice Explaining Gospel Truths

Throughout your life, you may be asked to explain your beliefs about the gospel—as a missionary, in Church callings, or to your family, friends, and acquaintances. Writing answers to gospel questions is a good way to learn how to respond to them clearly and briefly. As you practice explaining the gospel in writing, it may be helpful to imagine you are writing to a specific person.





5. Answer the following questions in your scripture study journal:

- How can direct and simple statements of principles be helpful in explaining and teaching the gospel?
- Write about an experience when the Articles of Faith or the truths they contain have helped you explain the gospel to someone. If you haven't had such an experience, list possible questions others might ask about our religion that could be answered by the Articles of Faith.

## THE ARTICLES OF FAITH

OF THE CHURCH OF JESUS CHRIST OF LATTER-DAY SAINTS

---

**W**E BELIEVE IN GOD, the Eternal Father, and in His Son, Jesus Christ, and in the Holy Ghost.

2 We believe that men will be punished for their own sins, and not for Adam's transgression.

3 We believe that through the Atonement of Christ, all mankind may be saved, by obedience to the laws and ordinances of the Gospel.

4 We believe that the first principles and ordinances of the Gospel are: first, Faith in the Lord Jesus Christ; second, Repentance; third, Baptism by immersion for the remission of sins; fourth, Laying on of hands for the gift of the Holy Ghost.

5 We believe that a man must be called of God, by prophecy, and by the laying on of hands by those who are in authority, to preach the Gospel and administer in the ordinances thereof.

6 We believe in the same organization that existed in the Primitive Church, namely, apostles, prophets, pastors, teachers, evangelists, and so forth.

7 We believe in the gift of tongues, prophecy, revelation, visions, healing, interpretation of tongues, and so forth.

8 We believe the Bible to be the word of God as far as it is translated correctly; we also believe the Book of Mormon to be the word of God.

9 We believe all that God has revealed, all that He does now reveal, and we believe that He will yet reveal many great and important things pertaining to the Kingdom of God.

10 We believe in the literal gathering of Israel and in the restoration of the Ten Tribes; that Zion (the New Jerusalem) will be built upon the American continent; that Christ will reign personally upon the earth; and, that the earth will be renewed and receive its paradisaical glory.

11 We claim the privilege of worshipping Almighty God according to the dictates of our own conscience, and allow all men the same privilege, let them worship how, where, or what they may.

12 We believe in being subject to kings, presidents, rulers, and magistrates, in obeying, honoring, and sustaining the law.

13 We believe in being honest, true, chaste, benevolent, virtuous, and in doing good to all men; indeed, we may say that we follow the admonition of Paul—We believe all things, we hope all things, we have endured many things, and hope to be able to endure all things. If there is anything virtuous, lovely, or of good report or praiseworthy, we seek after these things.

JOSEPH SMITH.

You may want to set a goal to study and memorize all of the Articles of Faith. Doing so will add to your ability to explain the principles of the gospel.



6. Write the following at the bottom of today's assignments in your scripture study journal:

*I have studied "The Coming Forth of the Pearl of Great Price" lesson and completed it on (date).*

*Additional questions, thoughts, and insights I would like to share with my teacher:*

## UNIT 31: DAY 3

# Official Declaration 1 and the Continued Development of Temple Work

## Introduction

Plural marriage is authorized only when commanded by the Lord to raise up seed to fulfill His purposes (see Jacob 2:27–30). After the Prophet Joseph Smith received revelation directing him to teach the principle of plural marriage, he entered into numerous marriages, and he authorized some Church members to practice plural marriage in the early 1840s. In subsequent decades, the Church experienced public opposition because of this practice. "After receiving revelation, President Wilford Woodruff issued the . . . Manifesto [Official Declaration 1], which was accepted by the Church as authoritative and binding on October 6, 1890. This led to the end of the practice of plural marriage in the Church" (Official Declaration 1, introduction). During this same period, the Saints diligently worked to build temples, where they received saving ordinances for themselves and for the dead.

## The Lord Reveals That Latter-day Saints Should Cease the Practice of Plural Marriage

Can you think of some examples of righteous individuals who have been arrested or imprisoned for doing what God commanded them to do?

Many Latter-day Saint men were arrested and imprisoned because they continued to obey the commandment to practice plural marriage after the United States government passed laws making the practice illegal. Some women were arrested as well, usually because they would not reveal the locations of their husbands, who had gone into hiding to avoid arrest.

As you read the following paragraph, mark some of the difficulties early Church members experienced as they obeyed the Lord's direction for them to practice plural marriage:

In August 1852, as part of a conference in Salt Lake City, Church leaders publicly announced that under commandment of God, some members of the Church were practicing plural marriage. Many religious and political leaders in the United States opposed this marriage system, which they considered immoral and uncivilized. Latter-day Saints were ridiculed in public speeches, books, magazines, and newspapers. The United States Congress passed laws that limited Church members' freedom and hurt the Church economically by restricting the amount of property the Church could own. These laws ultimately led to the arrest and imprisonment of men who had more than one wife. These men were denied "the right to vote, the right to privacy in their homes, and the enjoyment of other civil liberties" (*Our Heritage: A Brief History of the Church of Jesus Christ of Latter-day Saints* [1996], 97). By 1890, hundreds of faithful Latter-day Saints had served time in prison for practicing plural marriage. Others went into hiding to avoid arrest and imprisonment. In these conditions, many families suffered from stress, grief, poverty, and hunger.



President Wilford Woodruff

These difficult circumstances led President Wilford Woodruff to prayerfully seek the Lord's guidance concerning the Saints' practice of plural marriage. In 1889, President Woodruff instructed Church leaders to discontinue teaching the principle of plural marriage.

However, some people published reports that the Church was still promoting the practice of plural marriage. These reports brought further opposition against the Church. In 1890, President Woodruff issued a Manifesto, which is now known as Official Declaration 1 in the Doctrine and Covenants.

In the first three paragraphs of Official Declaration 1, President Woodruff declared that the reports alleging that the Church was still promoting the practice of plural marriage were not accurate.

Read the fourth and fifth paragraphs of Official Declaration 1 (beginning with "Inasmuch as laws") and the subsequent statement by President Lorenzo Snow, who was then President of the Quorum of the Twelve Apostles. Look for and mark what President Woodruff instructed the Saints to do.

According to the statement by President Lorenzo Snow, why was it important that the direction to refrain from contracting any more plural marriages came through the President of the Church?

It is important to understand that the President of the Church is the only person on the earth who holds the keys of the sealing ordinances. Plural marriage could be authorized only through the priesthood keys given to the President of the Church (see D&C 132:7, 48).

Read the first paragraph of "Excerpts from Three Addresses by President Wilford Woodruff Regarding the Manifesto," which follows the text of the Manifesto. Look for and mark a principle President Woodruff taught the Saints.



1. Answer the following questions in your scripture study journal:

- a. What principle did President Woodruff teach the Saints?
- b. Why do you think it is important that we have a testimony that the Lord will never permit the President of the Church to lead the Church astray?

Some Church members wondered why they were directed to live the principle of plural marriage but then directed to stop. The Lord directed President Woodruff to ask the Saints a question. Read the third, fourth, and fifth paragraphs of "Excerpts from Three Addresses by President Wilford Woodruff" (beginning with "I have had some revelations"), looking for the question President Woodruff asked the Saints.

The Saints were in danger of losing the St. George Utah Temple, the Logan Utah Temple, the Manti Utah Temple, and the nearly completed Salt Lake Temple. What important work would cease if the United States government seized the temples?



The Saints were in danger of losing the temples

Read the seventh paragraph of “Excerpts from Three Addresses by President Wilford Woodruff” (beginning with “. . . I saw exactly”), looking for what President Woodruff would have done if God had not commanded him to instruct Church leaders to discontinue the practice of performing plural marriages.

What can we learn from President Woodruff’s statement “I wrote what the Lord told me to write”?

One doctrine we can learn from this excerpt is that **the Lord directs His Church through revelation to the President of the Church.**



**2. Complete two or all of the following activities in your scripture study journal:**

- a. Think about times when you have witnessed the Lord directing His Church through revelation to the President of the Church. Describe two of the examples you thought of.
- b. Write 2–3 sentences about how your faith in this doctrine has influenced the choices you have made.
- c. Ask a family member or friend how he or she knows that the Lord directs His Church through revelation to the President of the Church. Write about what you learned from the conversation.

A small number of Latter-day Saints continued to enter into new plural marriages after the Manifesto was given. In 1904, President Joseph F. Smith presented an official statement “that all [plural] marriages are prohibited, and if any officer or member of the Church shall assume to solemnize or enter into any such marriage he will be deemed [considered] in transgression against the Church . . . and excommunicated therefrom” (in Conference Report, Apr. 1904, 75). This policy continues today. For more information, go to [LDS.org](http://LDS.org), select **Gospel Topics**, and search for **plural marriage**.

The following statement, which serves as the introduction to Official Declaration 1 in the 2013 edition of the scriptures, can help you answer questions about Latter-day Saints’ practice of plural marriage in the 1800s.



Photograph of President Joseph F. Smith (center) and his family

“The Bible and the Book of Mormon teach that monogamy is God’s standard for marriage unless He declares otherwise (see 2 Samuel 12:7–8 and Jacob 2:27, 30). Following a revelation to Joseph Smith, the practice of plural marriage was instituted among Church members in the early 1840s (see section 132). From the 1860s to the 1880s, the United States government passed laws to make this religious practice illegal. These laws were eventually upheld by the U.S. Supreme Court. After receiving revelation, President Wilford Woodruff issued the following Manifesto, which was accepted by the Church as authoritative and binding on October 6, 1890. This led to the end of the practice of plural marriage in the Church.”



**3. Based on what you have learned today, how would you respond if someone asked you if Latter-day Saints practice plural marriage? Write your response in your scripture study journal.**

### Temple Work Moves Forward

After the Manifesto was given, the threat of the federal government taking the temples and the property of the Church ended. Without that distraction, the Saints were able to give greater focus to temple work. In 1893, 40 years after the cornerstones of the Salt Lake Temple were laid, President Wilford Woodruff dedicated that temple, bringing the total number of functioning temples to four.



In April 1894, one year after the dedication of the Salt Lake Temple, President Woodruff announced that he had received a revelation clarifying the practice of the sealing ordinances, or eternal sealings. Before this revelation, Church members, acting according to the knowledge they possessed, often had themselves sealed, or “adopted,” to Church leaders rather than to their own parents. Based on the new revelation, which he testified was “the will of the Lord to this people,” President Woodruff directed the Saints “to trace their genealogies as far as they can, and to be sealed to their fathers and mothers. Have children sealed to their parents, and run this chain through as far as you can get it” (*Teachings of Presidents of the Church: Wilford Woodruff* [2004], xxxiv–xxxv).

Based on this statement by President Woodruff, we learn the following principle: **We can be sealed to our family members, including those who came before us and those who come after us, through the sealing ordinance.**

 **4.** Respond to the following question in your scripture study journal: How can the sealing ordinance be a blessing to you and your family during this life and hereafter?

 **5.** Write the following at the bottom of today’s assignments in your scripture study journal:

*I have studied the “Official Declaration 1 and the Continued Development of Temple Work” lesson and completed it on (date).*

*Additional questions, thoughts, and insights I would like to share with my teacher:*



Sealing ordinances to unite families for eternity are performed only in temples.

## UNIT 31: DAY 4

# Doctrine and Covenants 138

## Introduction

On October 3, 1918 President Joseph F. Smith received the vision recorded in Doctrine and Covenants 138. In this vision he saw the resurrected Savior minister to righteous spirits awaiting deliverance from the bands of death.

## Doctrine and Covenants 138:1–11

*President Joseph F. Smith ponders the scriptures and the Atonement of Jesus Christ*

Have you had a loved one pass away, or do you know a friend who has had a loved one pass away? When a person dies, the spirit and the body separate, and his or her spirit goes to the spirit world. What do you imagine the spirit world is like?





President Joseph F. Smith

President Joseph F. Smith, the sixth president of the Church, received a revelation about the spirit world. Read the introduction to Doctrine and Covenants 138, looking for what President Smith experienced during the months before the October 1918 general conference.

During those months President Joseph F. Smith was mourning the loss of his son Hyrum Mack Smith, who had served as a member of the Quorum of the Twelve Apostles. Hyrum Mack Smith had died earlier that year from a ruptured appendix at the age of 45.

Read Doctrine and Covenants 138:1–4, looking for the doctrine President Joseph F. Smith was pondering on October 3, 1918.

In verse 4, we learn that **through the Atonement of Jesus Christ and by obedience to the principles of the gospel, all mankind may be saved.**

Read Doctrine and Covenants 138:5, looking for what President Smith experienced as he pondered the Atonement.

Have you ever had a scripture come to mind as you pondered an aspect of the gospel? By continuing to study the word of God and master key scripture passages, you will find that the Holy Ghost can bring them to your mind when needed.

Read Doctrine and Covenants 138:6–10, looking for the teachings that impressed President Smith.

President Smith opened his scriptures and read scripture passages in 1 Peter 3 and 4. In these passages Peter explained that Jesus Christ visited the spirit world after He died. The Savior taught the gospel in the spirit world so that everyone could be judged fairly.

Read Doctrine and Covenants 138:11, looking for what President Smith saw as he pondered the scriptures.

Before you learn about President Smith’s vision of the spirit world, notice the process of revelation he described: As he was pondering the scriptures, he reflected on the doctrine of the Atonement and the love evidenced by Heavenly Father and Jesus Christ in the coming of the Savior into the world. These thoughts brought to his mind the words of Peter. Then, as he again read and pondered Peter’s words, “the eyes of [his] understanding were opened” (D&C 138:11), the Holy Ghost rested on him, and he saw the spirit world. One principle we can learn from this account is that **as we read and ponder the scriptures, we prepare ourselves to receive revelation.**



1. Answer the following questions in your scripture study journal:

- How does reading and pondering the scriptures help invite revelation?
- Describe an experience when you followed this pattern in your scripture study. How did following this pattern change your scripture study experience?

Elder D. Todd Christofferson of the Quorum of the Twelve Apostles described how we should study the scriptures. As you read his description, mark any ideas that you could apply as you study the scriptures.



“When I say ‘study,’ I mean something more than reading. . . . I see you sometimes reading a few verses, stopping to ponder them, carefully reading the verses again, and as you think about what they mean, praying for understanding, asking questions in your mind, waiting for spiritual impressions, and writing down the impressions and insights that come so you can remember and learn more” (“When Thou Art Converted,” *Ensign* or *Liahona*, May 2004, 11).

Consider setting a goal to read and ponder the scriptures the way Elder Christofferson described this week.

## Doctrine and Covenants 138:12–24, 38–50

*Joseph F. Smith sees the righteous dead awaiting their resurrection*

What future event are you looking forward to the most? Why are you excited for it?

When President Joseph F. Smith saw the spirit world in vision, he saw an immense group of spirits gathered together. Read Doctrine and Covenants 138:12–13, looking for what kind of spirits were gathered. You may want to mark what you find.

Read Doctrine and Covenants 138:38–49, looking for the names of some of the individuals gathered in this assembly.

Read Doctrine and Covenants 138:15–16, 50. What kind of deliverance were these righteous spirits waiting for? Ponder for a moment why the reunion of their spirits and bodies would be like a deliverance for these righteous spirits.

Read Doctrine and Covenants 138:17 to find the blessings that righteous souls receive after their spirits and bodies reunite.

From Doctrine and Covenants 138:16–17, we learn the following doctrines: **Through the grace of God the Father and Jesus Christ, we will be delivered from the bands of death. We can receive a fulness of joy through resurrection.**

As you read the following statement by Elder David A. Bednar of the Quorum of the Twelve Apostles, look for why our bodies are essential to receiving a fulness of joy:



“Our physical bodies make possible a breadth, a depth, and an intensity of experience that simply could not be obtained in our premortal existence. Thus, our relationships with other people, our capacity to recognize and act in

accordance with truth, and our ability to obey the principles and ordinances of the gospel of Jesus Christ are amplified through our physical bodies. . . .

“The Father’s plan is designed to provide direction for His children, to help them become happy, and to bring them safely home to Him with resurrected, exalted bodies” (“We Believe in Being Chaste,” *Ensign* or *Liahona*, May 2013, 41, 43).

Think about the following question for a moment: Why do we need a body to receive a fulness of joy?

A fulness of joy is the kind of joy Heavenly Father experiences. Heavenly Father has a physical body of flesh and bones (see D&C 130:22). When our spirits

and bodies are separated, we are unlike Him and cannot receive a fulness of joy (see D&C 93:33–34). As we become like Him, we can experience the same blessings, peace, and joy He experiences.

Read Doctrine and Covenants 138:51–52, looking for additional phrases that describe what the resurrection will allow righteous souls to do. Consider marking what you find.

 **2.** Imagine that one of your friends asked you to explain why the resurrection is important in Heavenly Father’s plan. Using what you have learned so far in Doctrine and Covenants 138 and the statement from Elder Bednar, write an explanation for your friend in your scripture study journal.

The righteous in the spirit world were waiting for the “advent,” or arrival, of the Son of God to free them and restore them to their “perfect frame” (D&C 138:16–17). Imagine what was happening on the earth while these righteous spirits were assembled. Jesus Christ was suffering in Gethsemane and on the cross. Some of the righteous spirits in the spirit world had waited thousands of years for their deliverance from death. Jesus Christ’s sacrifice provided salvation from physical death for them, and eventually for all people.

Read Doctrine and Covenants 138:18–24, and imagine what the event described in these verses might have been like.

### Visualization

Look for descriptive details that can help you create a mental picture as you read. Imagining that you were present at certain events can help strengthen your testimony of the reality of what you read in the scriptures.

 **3.** Answer the following questions in your scripture study journal:

- What might you have thought or felt if you had been there to hear the Savior preach in the spirit world?
- How might you have responded to the Savior, who had just performed the Atonement for you?

## Doctrine and Covenants 138:25–37

*President Joseph F. Smith learns how the gospel is preached in the spirit world*

You may have noticed in Doctrine and Covenants 138:20–22 that there were some spirits who were not able to see the Savior when He visited the spirit world. While President Joseph F. Smith was pondering passages in 1 Peter, the Lord revealed to him how the people in spirit prison will have the opportunity to receive the blessings of the gospel. Read Doctrine and

Covenants 138:29–31, looking for how the spirits in prison would receive knowledge of the gospel. You may want to mark what you find.

 **4.** In your scripture study journal, use what you learned in verses 29–31 to write a brief explanation of how the gospel is taught in the spirit world.

In Doctrine and Covenants 138:32–37, President Joseph F. Smith wrote that he saw the gospel of Jesus Christ being taught to two types of spirits in prison: those who had died without a knowledge of the gospel and those who had rejected the prophets in mortality. These spirits, who were in spirit prison, would all receive a chance to repent and accept the gospel through the teachings of the Lord’s chosen messengers.

### Doctrine and Covenants 138:53–60

*President Smith sees the noble and great spirits who would preach the gospel in spirit prison*

Think of your righteous family members or ancestors who have died. Have you ever wondered what they are doing in the spirit world?

As part of the vision, President Joseph F. Smith saw his father, Hyrum Smith; his uncle Joseph Smith; and other choice spirits. All of these noble spirits contributed to the work of the Lord in mortality. They and many others were prepared before they were born to accomplish great things on earth.

Read Doctrine and Covenants 138:57, looking for what faithful elders will continue to do after they die. You may want to mark what you find.



President Joseph F. Smith also explained that the work in the spirit world is not limited to those who hold the Melchizedek Priesthood: “Good sisters who have been set apart, ordained to the work, [and] called to it, . . . will be fully authorized and empowered to preach the gospel” (*Gospel Doctrine*, 5th ed. [1939], 461).

One of the truths we learn from Doctrine and Covenants 138:57 and President Smith’s statement is that **after departing mortal life, faithful Saints will continue their labors in preaching the gospel.**

Read Doctrine and Covenants 138:60, looking for President Joseph F. Smith’s testimony of the truths he recorded.

It is a wonderful blessing to know that all of Heavenly Father’s children will receive an opportunity to accept and live the gospel. The work we do for the dead in the

temple gives them the ability to be cleansed from their sins, redeemed from spirit prison, and join the great work of redemption in the spirit world.

 **5.** Write the following at the bottom of today’s assignments in your scripture study journal:

*I have studied Doctrine and Covenants 138 and completed this lesson on (date).*

*Additional questions, thoughts, and insights I would like to share with my teacher:*

## UNIT 32: DAY 1

# Church Organizations and Programs

### Introduction

As the Church has continued to expand, the Lord has inspired Church leaders and members to implement organizations and programs within the Church to bless the Saints. When these organizations and programs were first established, they were not as critically needed as at present, but as the Church has grown, they have become crucial in the Church’s work of the salvation of God’s children.

### Church Organizations and Programs Help Us Prepare and Progress toward Eternal Life

Think about how Church organizations and programs have blessed your life.

What would you say is the purpose of Church organizations like Young Men and Young Women? How can knowing the purpose of an organization help those who participate in it?

Read Moses 1:39, looking for what Heavenly Father’s purpose is in all that He does. Remember that *immortality* refers to living forever in a resurrected state. Through the Atonement of Jesus Christ, all people will be resurrected, regardless of their wickedness or righteousness in this life. *Eternal life* refers to living forever as families in Heavenly Father’s presence and becoming like Him.

Considering that Heavenly Father’s purpose is to bring to pass the immortality and eternal life of His children, what is the purpose of the Church?



Because Heavenly Father’s purpose is to bring about the immortality and eternal life of His children, the purpose of His Church is the same. **Heavenly Father established The Church of Jesus Christ of Latter-day Saints to help His children obtain eternal life.**

 **1.** In your scripture study journal, list some ways the Church helps Heavenly Father bring to pass the immortality and eternal life of His children.

The Church has a number of organizations—called auxiliaries to the priesthood—and other programs that help us progress toward eternal life. Try to name some of them.

You might have named Young Men, Young Women, Primary, Relief Society, and Sunday School and programs such as Seminaries and Institutes of Religion and family home evening.

To see how Church organizations and programs help us learn and progress in the gospel so that we can receive eternal life, read the following statement by President Boyd K. Packer of the Quorum of the Twelve Apostles. This statement is about the seminary and institute programs, but the principle it teaches can also apply to the other Church auxiliaries and programs.



“In the history of the Church there is no better illustration of the prophetic preparation of this people than the beginnings of the seminary and institute program. These programs were started when they were nice but were not critically needed. They were granted a season to flourish and to grow into a bulwark [defense] for the Church. They now become a godsend for the salvation of modern Israel in a most challenging hour” (“Teach the Scriptures” [address to CES religious educators, Oct. 14, 1977], 3; si.lds.org).

The Lord has inspired His leaders to establish the many programs and organizations in the Church to prepare us for the tests and challenges we face during this mortal life and to help us progress toward eternal life.

As you read each of the following historical summaries, look for answers to the following questions:

- How did the organization or program begin? (Consider marking answers to this question.)
- How do you think it prepares us to face the tests and challenges of our day?
- How do you think it helps us progress toward eternal life?

## Sunday School



In 1849 a Church member named Richard Ballantyne felt that children needed a place to learn the gospel on the Sabbath day. Saints in Great Britain were already holding Sunday School classes, and Brother Ballantyne started the first Sunday School class in Utah in his Salt Lake City ward in December 1849. Soon after that, other wards began to adopt the same practice, each using its own curriculum. In 1867, Church leaders formed the Deseret Sunday School Union, which fostered uniformity in curriculum. By 1870, more than 200 Sunday School classes had been formed. Today, wards and branches have multiple Sunday School classes.

## Young Women



President Brigham Young met with his daughters in his home on November 28, 1869, and asked them to be leaders to help their peers gain testimonies of the gospel, be modest in their dress and their actions, and avoid trends and behaviors of the world. In 1870 a formal organization of young women was organized to promote these objectives. This organization eventually was known as the Young Women’s Mutual



Improvement Association (YWMIA), which later changed to Young Women. In the early 1970s, leaders introduced the Personal Progress program. In 1985 they introduced the Young Women values and theme.

## Young Men



The Young Men's Mutual Improvement Association (YMMIA) was organized on June 10, 1875, under the direction of President Brigham Young. This organization was intended to help young men develop spiritually and intellectually as well as provide them with recreational activities. In 1913, the Church partnered with Boys Scouts of America in the United States. Internationally, partnerships with other Scouting programs have been formed where advisable. The organization's name evolved as well, first changing to Aaronic Priesthood–MIA, then Aaronic Priesthood, and then Young Men. In 2001, Church leaders introduced the Duty to God program.

## Primary



In 1877, Aurelia Spencer Rogers “felt strongly that something should be done about the behavior of the neighborhood boys who ran freely through the town

day and night. She felt many of these children were not being taught basic principles and values [to prepare them] in either knowledge or behavior to carry the gospel forward, or even to be good parents or citizens” (“History of Primary,” [lds.org/callings/primary/getting-started/history-of-primary](https://www.lds.org/callings/primary/getting-started/history-of-primary)). She met with Eliza R. Snow, who at the time was serving as the Relief Society general president, and they obtained permission from President John Taylor to organize a Primary in Farmington, Utah, under the direction of Bishop John Hess. The first Primary meeting, held on August 25, 1878, consisted of 224 boys and girls. In 1880, a general Primary president was called, and Primary classes began to be organized in many wards.

## Seminaries and Institutes of Religion



In 1888 the Church established a general Board of Education and Church academies and created religion classes to provide a spiritual foundation for secular learning for those who did not attend Church academies. In 1912, Joseph F. Merrill, a professor and Church member, proposed a plan to allow students in public schools to attend religion classes as part of their school day. It was called seminary, and the first classes were held near Granite High School in Salt Lake City, Utah, with 70 students enrolled. As the seminary program spread, a similar program was established for college-age youth. It was named the Latter-day Saint Institute of Religion, and institute classes began in 1926 in Moscow, Idaho. In the early 1950s an early-morning seminary program began in California, the home-study seminary program began in the 1960s, and seminaries and institutes of religion have continued to expand throughout the world.

## Family Home Evening



President Joseph F. Smith taught that Church programs should be “supplements to our teachings and training in the home. Not one child in a hundred would go astray, if the home environment, example, and training, were in harmony with the truth in the Gospel of Christ” (“Worship in the Home,” *Improvement Era*, Dec. 1903, 138). In 1909 the Granite Stake in Salt Lake City, Utah, began a weekly home evening program, which President Smith said was inspired. In 1915 the First Presidency recommended that monthly home evenings be adopted throughout the Church. The First Presidency promised: “If the Saints obey this counsel [to observe home evenings], we promise that great blessings will result. Love at home and obedience to parents will increase. Faith will be developed in the hearts of the youth of Israel, and they will gain power to combat the evil influence and temptations which beset them” (in James R. Clark, comp., *Messages of the First Presidency of The Church of Jesus Christ of Latter-day Saints*, 6 vols. [1965–75], 4:339). Fifty years later, the Church published manuals for families to use in weekly gospel instruction. In 1970, Church leaders designated Monday evenings for family home evening and announced that no other Church activities were to be held that night.

Each Church organization and program originally operated independently. As the Church expanded dramatically in the 1950s, Church leaders saw a need to evaluate how Church organizations were meeting the Church’s objectives. They decided to unify and coordinate all Church organizations and programs both in administration and in selecting curriculum.

These changes helped the organizations and programs to better meet the complex needs of the growing Church and to strengthen the family. Under this correlation effort, **all Church organizations operate under the direction of priesthood leaders, who hold the keys to preside.**

In addition, under the direction of the First Presidency and Quorum of the Twelve Apostles, a Correlation Department was formed to review, evaluate, and correlate all materials published by the Church. This was done to help keep the doctrine pure so that Church teachings are not misunderstood.

Ponder how having the auxiliaries of the Church unified and correlated under the direction of the priesthood can help to better accomplish Heavenly Father’s purpose for His children.

 **2.** Ponder the following principle: **As we participate in Church organizations and programs, we receive the blessings available through them.** Then answer the following questions in your scripture study journal:

- a. How have Church organizations and programs blessed your life?
- b. How has the Duty to God or the Personal Progress program blessed your life?

 **3.** In your scripture study journal, write one or two goals to improve your participation in the Church auxiliaries and programs. The following questions may help you think about what goals to set: How will you participate more fully in Young Men or Young Women? In Sunday School? In family home evening? In seminary?

 **4.** Answer the following question in your scripture study journal: How can participating in these auxiliaries and programs help prepare you to receive the Melchizedek Priesthood or transition into Relief Society?

 **5.** Write the following at the bottom of today’s assignments in your scripture study journal:

*I have studied the “Church Organizations and Programs” lesson and completed it on (date).*

*Additional questions, thoughts, and insights I would like to share with my teacher:*

# Official Declaration 2

## Introduction

During the 20th century, missionary work spread throughout the earth. Church leaders prayed for guidance concerning restrictions on priesthood ordination and temple ordinances for Church members of African descent. A definitive revelation came to Church President Spencer W. Kimball and was affirmed to his counselors in the First Presidency and the members of the Quorum of the Twelve Apostles in the Salt Lake Temple on June 1, 1978. In a letter dated June 8, 1978, they announced the revelation.

## Official Declaration 2

*The Lord reveals that priesthood and temple blessings may be extended to every worthy Church member*

Imagine you have a friend who is a Latter-day Saint and is struggling with some questions about the doctrines, policies, or practices of the Church.



1. Answer the following question in your scripture study journal: What would you encourage your friend to do?

In the following statement by President Dieter F. Uchtdorf of the First Presidency, mark the portions that are especially helpful to you:



“What about doubts and questions? How do you find out that the gospel is true? Is it all right to have questions about the Church or its doctrine? My dear young friends, we are a question-asking people because we know that inquiry leads to

truth. That is the way the Church got its start—from a young man who had questions. In fact, I’m not sure how one can discover truth without asking questions. In the scriptures you will rarely discover a revelation that didn’t come in response to a question. Whenever a question arose and Joseph Smith wasn’t sure of the answer, he approached the Lord, and the results are the wonderful revelations in the Doctrine and Covenants. Often the knowledge Joseph received extended far beyond the original question. That is because not only can the Lord answer the questions we ask but, even more importantly, He can give us answers to questions we should have asked. Let us listen to those answers.

“The missionary effort of the Church is founded upon honest investigators asking heartfelt questions. Inquiry is the birthplace of testimony. Some might

feel embarrassed or unworthy because they have searching questions regarding the gospel, but they needn’t feel that way. Asking questions isn’t a sign of weakness; it’s a precursor of growth.

“God commands us to seek answers to our questions (see James 1:5–6) and asks only that we seek ‘with a sincere heart, with real intent, having faith in Christ’ (Moroni 10:4). When we do so, the truth of all things can be manifested to us ‘by the power of the Holy Ghost’ (Moroni 10:5).

“Fear not; ask questions. Be curious, but doubt not! Always hold fast to faith and to the light you have already received. Because we see imperfectly in mortality, not everything is going to make sense right now. . . .

“. . . Searching for answers to your questions can bring you closer to God, strengthening your testimony instead of shaking it. It’s true that ‘faith is not . . . a perfect knowledge’ (Alma 32:21), but as you exercise your faith, applying gospel principles every day under any circumstances, you will taste the sweet fruits of the gospel, and by this fruit you will know of its truth (see Matthew 7:16–20; John 7:17; Alma 32:41–43)” (“The Reflection in the Water” [Church Educational System fireside address, Nov. 1, 2009], LDS.org).

The following account illustrates how two individuals, Helvécio and Rudá Martins, sought to receive and understand truth by asking questions:



Elder Helvécio Martins



“On a clear April night in 1972 . . . Helvécio Martins contemplated his family’s search for truth. He and his wife, Rudá, had investigated many religions, but none seemed to fill their spiritual void. ‘I conversed with God that night, asking for help’ he says” (“Elder Helvécio Martins Of the Seventy,” *Ensign*, May 1990, 106).

A few days later, missionaries came to their home in Rio de Janeiro, Brazil. Elder Martins recalled, “The moment those two young men stepped into our apartment, all of my gloom and spiritual discomfort immediately disappeared and was replaced by a calm and serenity which I now know came from the influence of the Holy Spirit” (with Mark Grover, *The Autobiography of Elder Helvécio Martins* [1994], 43).

As Helvécio and Rudá, who are of African descent, conversed with the missionaries, Helvécio asked about the role of black people in the Church. The Martins learned that at that time, Church policy restricted black males of African descent from being ordained to the priesthood. This led them to ask the missionaries further questions.

If you had been in the position of the Martins family, what questions might you have had as you learned of the priesthood restriction?

The following statement is the introduction to Official Declaration 2 in the 2013 edition of the scriptures. As you read the statement, look for answers to questions individuals may have had about the priesthood restriction.

“The Book of Mormon teaches that ‘all are alike unto God,’ including ‘black and white, bond and free, male and female’ (2 Nephi 26:33). Throughout the history of the Church, people of every race and ethnicity in many countries have been baptized and have lived as faithful members of the Church. During Joseph Smith’s lifetime, a few black male members of the Church were ordained to the priesthood. Early in its history, Church leaders stopped conferring the priesthood on black males of African descent. Church records offer no clear insights into the origins of this practice. Church leaders believed that a revelation from God was needed to alter this practice and prayerfully sought guidance. The revelation came to Church President Spencer W. Kimball and was affirmed to other Church leaders in the Salt Lake Temple on June 1, 1978. The revelation removed all restrictions with regard to race that once applied to the priesthood.”

 **2.** Answer the following question in your scripture study journal: What questions about the priesthood restriction can be answered through this statement?

Notice the following line in the statement above: “Church records offer no clear insights into the origin of this practice.” Although some people may suggest reasons why males of African descent were not ordained to the priesthood for a time, those reasons are likely not accurate. The statement in the introduction to Official Declaration 2 represents the official position of the Church.

As you read the following paragraph, look for what the Martins family did after they learned about the restored gospel:

The Martins family was baptized on July 2, 1972, and served faithfully in the Church. When their oldest son, Marcus, received his patriarchal blessing, it promised that he would preach the gospel. Although the priesthood restriction at that time prevented Marcus from serving a full-time mission, his parents opened a missionary savings account. In 1975 the Church announced that a temple would be built in São Paulo, Brazil. To help with the fundraising, Sister Martins sold her jewelry. Brother Martins faithfully served as a member of the publicity committee for the temple. The Martins family made these sacrifices even though they believed they would not have the opportunity to receive priesthood ordinances in the temple.

 **3.** Answer the following question in your scripture study journal: Why do you think the Martins family was willing to be baptized and serve faithfully in the Church, even though they were affected by the priesthood restriction at that time?

Compare your answer with the following statement Elder Martins gave: “We had found the truth, and nothing would stop us from living it. . . . When the Spirit tells you the gospel is true, . . . how can you deny it?” (in “Elder Helvécio Martins of the Seventy,” 106).

Because the Martins family had received a testimony through the Holy Ghost, they were able to move forward, trusting in the Lord, in spite of things they did not understand.

In addition to the Martins family, thousands of people of African descent in various nations had come to know of the truthfulness of the restored gospel in the decades preceding the 1978 revelation. Church leaders in Salt Lake City received a flood of letters from unbaptized converts in Nigeria and Ghana requesting that missionaries be sent to Africa. For years, Church leaders prayerfully considered the matter but felt the time had not yet come to send missionaries to Africa, where local members would not be able to preside or perform ordinances.





President Spencer W. Kimball

Official Declaration 2 contains the official announcement of a revelation President Spencer W. Kimball received on June 1, 1978. Read the first paragraph under the phrase “Dear Brethren,” looking for what Church leaders said they had witnessed.

What were Church leaders inspired with as they witnessed the expansion of the Lord’s work?

Read the paragraph beginning “Aware of the promises.” Look for how Church leaders acted on the desires they were inspired with.

How did President Kimball and other Church leaders act on their inspired desires? \_\_\_\_\_

This paragraph helps us understand that **prophets seek the Lord’s guidance in directing the Church**. You may want to write this principle in your scriptures.

Notice that the beginning of that second paragraph begins with the phrase, “Aware of the promises made by the prophets.” This phrase teaches us that Church leaders knew that at some time all worthy men would have the opportunity to receive the priesthood. For many years before 1978, the First Presidency and the Quorum of the Twelve Apostles had discussed and prayed about the priesthood restriction. Church leaders felt that revelation was needed in order to change the

restriction, which had been established for more than a century. For some time the question weighed heavily on President Kimball’s mind, and he often went to the temple alone to pray about it.

Read the paragraphs in Official Declaration 2 that begin with “He has heard our prayers” and “We declare,” looking for the Lord’s response to the prayers of President Kimball, his counselors in the First Presidency, and members of the Quorum of the Twelve Apostles. You may want to mark what you find.

These paragraphs help us understand that **the Lord directs His Church through revelation to His prophets**. You may wish to write this doctrine in your scriptures.

This revelation had a profound impact on people throughout the world. Read the reaction of Helvécio Martins and his wife, Rudá, when they learned about the revelation: “I could not contain my emotions. Rudá and I went into our bedroom, knelt down, and prayed. We wept as we thanked our Father in Heaven for an event we had only dreamed about. The day had actually arrived, and in *our* mortal lives” (*Autobiography*, 69–70).

The Martins family was sealed in the temple. Their son Marcus was the first Church member of African descent to serve a mission after the revelation to end the priesthood restriction. Helvécio Martins became a local priesthood leader and eventually was called to serve as a member of the Second Quorum of the Seventy.

Soon after the revelation ending the priesthood restriction was received, missionaries were sent to Africa. Temples have since been built on that continent, and hundreds of thousands of people there have received the ordinances of the gospel for themselves and for their deceased ancestors.

You may be asked why the Church did not ordain men of African descent to the priesthood for a time. Consider how you might answer this question. For more information, go to [LDS.org](http://LDS.org), select **Gospel Topics**, and search for **race and the priesthood**.



**4.** It is appropriate to explain to others that we do not know why the priesthood restriction began. In addition, you can share and testify of the truths we do know, such as those you have learned in this lesson. In your scripture study journal, write how you might answer questions about why the Church did not ordain men of African descent to the priesthood for a time. As you form your answer, you might want to use the Martins family’s example as well as the introduction to Official Declaration 2 in the 2013 edition of the scriptures.



5. Write the following at the bottom of today's assignments in your scripture study journal:

*I have studied Official Declaration 2 and completed this lesson on (date).*

*Additional questions, thoughts, and insights I would like to share with my teacher:*

## UNIT 32: DAY 3

# Hastening the Work of Salvation

### Introduction

Since the beginning of the Restoration, the work of the Lord has expanded throughout the world. We live in a time when the Lord is hastening His work. You have many resources and opportunities to contribute to the hastening of the Lord's work.

### The Lord Is Hastening His Work

What are some reasons someone might hasten, or accelerate, the pace of doing a task? Read Doctrine and Covenants 88:73, looking for what the Lord said He would hasten (see also Jacob 5:61–62, 70–71).

Referring to Doctrine and Covenants 88:73, Elder Russell M. Nelson of the Quorum of the Twelve Apostles said, "That time of hastening is now" ("Thus Shall My Church Be Called," *Ensign*, May 1990, 17).

**We live in a time when the Lord is hastening His work.** By hastening His work, the Lord is accelerating and further advancing His efforts to bring about the salvation of man.



1. Answer the following question in your scripture study journal: What are some of the ways you have witnessed the Lord hastening His work?

During President Spencer W. Kimball's service as President of the Church, the Lord hastened His work. For example, missionary work expanded, and the Church published new editions of the scriptures. As he encouraged Church members to press forward, President Kimball said that the Church had "paused on some plateaus long enough. Let us resume our journey forward and upward" ("Let Us Move Forward and Upward," *Ensign*, May 1979, 82). He also taught, "We must lengthen our stride and must do it now"

("Always a Convert Church: Some Lessons to Learn and Apply This Year," *Ensign*, Sept. 1975, 3).

When Church members "lengthen their stride," they increase their efforts to participate in the Lord's work. For example, they work more diligently to share the gospel, study the scriptures, and do temple and family history work.

### Hastening Missionary Work

President Spencer W. Kimball told the Saints that the Lord was prepared to open doors for them to share the gospel, including in nations that did not allow missionary work. However, he also said that the Saints needed to prepare themselves to receive those opportunities. President Kimball also testified that if every young man prepared to serve a full-time mission, the Lord would open doors and provide a way for missionary work to go forth to the entire world:



"I think of the numerous nations that are still untouched. I know they have curtains [restrictions against outside influences], like iron curtains and bamboo curtains. I know how difficult it is because we have made some efforts. . . .

"But I can see no good reason why the Lord would open doors that we are not prepared to enter. Why should he break down the Iron Curtain or the Bamboo Curtain or any other curtain if we are still unprepared to enter?" ("When the World Will Be Converted," *Ensign*, Oct. 1974, 5, 7).

Members of the Church followed President Kimball's counsel and prepared to share the gospel. During President Kimball's administration the number of full-time missionaries increased by more than 50 percent. In the late 1980s and early 1990s, the governments of East Germany, nations within the former Soviet Union, and other nations where missionary work had previously been restricted began allowing missionaries to share the gospel in these countries. President Kimball's prophecy was fulfilled, and it continues to be fulfilled as missionary work expands.

As President Kimball encouraged Church members to lengthen their stride, he clarified a responsibility of every young man in the Church: "The question is frequently asked: Should every young man fill a mission? And the answer has been given by the Lord. It is 'Yes.' Every young man should fill a mission" ("When the World Will Be Converted," 8).

Since then, prophets have continued to encourage every worthy, able young man to serve a full-time mission. Prophets have also welcomed young women to serve full-time missions if they desire to do so. In



October 2012, President Thomas S. Monson announced an inspired change in missionary age requirements, allowing young men to begin missionary service at age 18 and young women at age 19. **Every young man should prepare to serve a full-time mission and keep himself worthy to serve.**



2. Answer the following questions in your scripture study journal:

- a. Why should every young man prepare to serve a full-time mission?
- b. How can preparing for a mission now help you contribute to the Lord's work?
- c. How do you think the inspired change in the age requirement for full-time missionaries has contributed to the hastening of the Lord's work?

## New Editions of the Scriptures

What would you say if a close friend said to you, "I want to come closer to God. What should I do?"

Read the following statement by President Spencer W. Kimball: "I find that when I get casual in my relationships with divinity and when it seems that no divine ear is listening and no divine voice is speaking, that I am far, far away. If I immerse myself in the scriptures the distance narrows and the spirituality returns" (*Teachings of Presidents of the Church: Spencer W. Kimball* [2006], 67).

Read Doctrine and Covenants 1:6, 24–30, and identify why the Lord wanted Church leaders to publish the revelations. How can the scriptures help us lengthen our stride and contribute to the hastening of the Lord's work?

In the early 1970s, Church leaders recognized the need for Church members to become more familiar with the scriptures and to have a standard edition of the Bible for study and teaching. In 1979, after years of inspired, diligent efforts, the Church printed an official English LDS edition of the King James Bible. This edition of the Bible contained extensive study aids not previously available, including expanded footnotes

with cross-references and other aids; improved chapter headings; excerpts from the Joseph Smith Translation; the Topical Guide; and the Bible Dictionary. In 1981, the Church published a new edition of the English triple combination—Book of Mormon, Doctrine and Covenants, and Pearl of Great Price—that included improved footnotes, chapter headings, maps, and an index. In 2009, the Church published the LDS edition of the Reina-Valera Bible in Spanish.

Read the following statement President Boyd K. Packer of the Quorum of the Twelve Apostles made one year after the release of the 1981 triple combination in English. Look for how he envisioned these new editions of the scriptures blessing lives and moving God's work forward.



"With the passing of years, these scriptures will produce successive generations of faithful Christians who know the Lord Jesus Christ and are disposed to obey His will.

"... The revelations will be opened to them as to no other in the history of the world. . . . They will develop a gospel scholarship beyond that which their forebears could achieve. They will have the testimony that Jesus is the Christ and be competent to proclaim Him and to defend Him" (*"Scriptures," Ensign*, Nov. 1982, 53).

## The scriptures testify that Jesus is the Christ.

Studying the scriptures can help us receive a testimony of Jesus Christ and help fill our lives with the Holy Spirit. Great efforts have been and continue to be made to provide Church members with scriptures and helpful study aids in their native languages.



3. Answer the following questions in your scripture study journal:

- a. Why is daily scripture study important?
- b. How has your personal scripture study helped you assist in the Lord's work?

## Hastening Temple and Family History Work

Temple construction increased most significantly under the direction of President Gordon B. Hinckley. In 1995, when there were less than 50 temples operating throughout the world, he said: "I have a burning desire that a temple be located within reasonable access to Latter-day Saints throughout the world. . . . The work is moving about as fast as we can go. It is my constant prayer that somehow it might be speeded up so that more of our people might have easier access to a sacred house of the Lord" ("Of



Missions, Temples, and Stewardship,” *Ensign*, Nov. 1995, 52–53).

Read Doctrine and Covenants 128:15, 17, looking for the responsibility we have to our ancestors. Elder David A. Bednar of the Quorum of the Twelve Apostles stated the following principle: **“We have the covenant responsibility to search out our ancestors and provide for them the saving ordinances of the gospel”** (“The Hearts of the Children Shall Turn,” *Ensign* or *Liahona*, Nov. 2011, 25).

The construction of temples and advancements in family history work are evidence that God is hastening His work on the other side of the veil.



Read the following statement by Elder Bednar, looking for how you can contribute to the Lord’s work: “It is no coincidence that FamilySearch and other tools have come forth at a time when young people are so familiar with a wide range of information and communication technologies. Your fingers have been trained to text and tweet to accelerate and advance the work of the Lord—not just to communicate quickly with your friends. The skills and aptitude evident among many young people today are a preparation to contribute to the work of salvation” (“The Hearts of the Children,” 26).

 **4.** Answer the following question in your scripture study journal: What positive experiences have you had in doing family history work or going to the temple to participate in ordinances for the dead?

## Our Responsibility in Moving the Work Forward

As you read the following statement by Elder David B. Haight of the Quorum of the Twelve Apostles, mark a blessing that is available to each of us:



“Brothers and sisters, the Lord is opening the way and making it possible to expand His work throughout the world, and what a blessing it is for all of us—each in his own way—to take part. . . .  
“Who but the prophets of God could have foreseen the miracle of the rapid expansion of the work of the Lord? Truly, as the Lord foretold in section 88 of the Doctrine and Covenants, He is hastening His work in its time (see D&C 88:73)” (“Missionary Work—Our Responsibility,” *Ensign*, Nov. 1993, 61–62).

**We can be blessed to take part in the hastening of the Lord’s work.** Consider the opportunities you have to contribute to the hastening of the Lord’s work.

 **5.** Answer the following questions in your scripture study journal:

- What are some ways you can contribute to the hastening of the Lord’s work?
- What blessings have you experienced as you have participated in the hastening of the Lord’s work?

 **6.** Write the following at the bottom of today’s assignments in your scripture study journal:

*I have studied the “Hastening the Work of Salvation” lesson and completed it on (date).*

*Additional questions, thoughts, and insights I would like to share with my teacher:*

## UNIT 32: DAY 4

# The Family: A Proclamation to the World

## Introduction

On September 23, 1995, in a general Relief Society meeting, President Gordon B. Hinckley introduced “The Family: A Proclamation to the World.” This proclamation from the First Presidency and the Quorum of the Twelve Apostles declares to the world the Lord’s standards and doctrines concerning the family. The proclamation also provides counsel for strengthening families and a warning about the consequences of the disintegration of families. (A copy of this family proclamation is at the end of this lesson.)

## The First Presidency and Quorum of the Twelve Apostles Issue a Proclamation to the World Concerning the Family

Have you ever had questions or know someone who has had questions related to one of the following issues?

- The importance of marriage and family
- Divorce
- Same-sex marriage
- Gender
- Unwed parents
- Having children
- Sexual relations outside of marriage



- Roles of mothers
- Roles of fathers
- Abortion

Many questions concerning these issues and other family matters can be answered using “The Family: A Proclamation to the World.”

Just before President Gordon B. Hinckley read this proclamation, he stated some of the reasons why the world needs the truths it contains. As you read his statement, look for and underline those reasons.



“With so much of sophistry that is passed off as truth, with so much of deception concerning standards and values, with so much of allurements and enticement to take on the slow stain of the world, we have felt to warn and forewarn. In

furtherance of this we of the First Presidency and the Council of the Twelve Apostles now issue a proclamation to the Church and to the world as a declaration and reaffirmation of standards, doctrines, and practices relative to the family which the prophets, seers, and revelators of this church have repeatedly stated throughout its history” (“Stand Strong against the Wiles of the World,” *Ensign*, Nov. 1995, 100).



**1.** To help you identify doctrines and principles that answer questions about the issues listed at the beginning of the lesson, copy the following chart into your scripture study journal, leaving room to write in your answers. (You may want to number the paragraphs in the copy of the proclamation at the end of this lesson.)

Issues Concerning the Family	Doctrines and Principles from the Family Proclamation	Taught in Which Paragraphs in the Proclamation?
The importance of marriage and family		
Divorce		
Same-sex marriage		
Gender	Gender is an essential characteristic of individual premortal, mortal, and eternal identity and purpose.	paragraph 2

Issues Concerning the Family	Doctrines and Principles from the Family Proclamation	Taught in Which Paragraphs in the Proclamation?
Having children		
Role of fathers		
Role of mothers		
Sexual relations outside of marriage		
Abortion	The creation of mortal life is a sacred and important part of Heavenly Father’s plan.	paragraphs 3 and 5

Read paragraphs 1–5 of the family proclamation, looking for doctrines and principles that relate to these issues concerning the family. From what you find in the family proclamation, identify the doctrine or principle that relates to each of the issues on the chart. Write these in the appropriate column, next to the corresponding issue in the chart in your journal. Also write which paragraph or paragraphs of the family proclamation you used to help you identify each doctrine or principle. (Information for two of the rows of the chart has been filled out for you as examples.)



**2.** Select two of the doctrines or principles you identified on your chart. In your scripture study journal, answer the following questions for each doctrine or principle you selected:

- Why do you think it is important to understand this doctrine or principle?
- How can understanding and believing this doctrine or principle influence the decisions you make?

### Applying Principles

A principle is an enduring truth or rule you can adopt to guide you in making decisions. You can use the principles found in the family proclamation to guide the decisions you make about the family you will create.

## The Family Proclamation Helps Us Establish Successful Families



Read paragraphs 6–7 of “The Family: A Proclamation to the World,” looking for things that can help you achieve happiness in your family.

One principle we learn from the family proclamation is that **happiness in family life is most likely to be achieved when founded upon the teachings of the Lord Jesus Christ.**

 **3.** In your scripture study journal, list the principles found in paragraph 7 of the family proclamation that help families find happiness. (You may want to mark these principles in your copy of the family proclamation.) Then answer the following questions:

- What examples have you seen of families following these teachings?
- Why do you think families that follow these teachings are more likely to be happy?

 **4.** Think about how these teachings can add to a family’s happiness. Consider which of these teachings you could live better in order to bring greater happiness to you and your family. In your scripture study journal, write a goal to help you better live one or more of these teachings in your family.

According to the last half of paragraph 7 of the family proclamation, what are the responsibilities of fathers? \_\_\_\_\_

\_\_\_\_\_

Think about the ways you have seen your father or other fathers fulfill these responsibilities.

According to the last half of paragraph 7, what is the primary responsibility of mothers? \_\_\_\_\_

\_\_\_\_\_

Think about ways you have seen your mother or other mothers fulfill this role?

According to paragraph 7, the responsibilities or roles of mothers and fathers are “by divine design.” This means they were established by our Heavenly Father. Why do you think this is important to understand?

\_\_\_\_\_

\_\_\_\_\_

In paragraph 7 we also learn that **fathers and mothers are obligated to help each other as equal partners in their family responsibilities.** Think about when you have seen mothers and fathers work together to help each other as equal partners in these sacred responsibilities.

The following sentence appears near the end of paragraph 7: “Disability, death, or other circumstances may necessitate individual adaptation.” The Lord is aware of these circumstances, and He blesses parents and families as they strive to fulfill their obligations to the best of their ability.

Reread the final sentence of paragraph 7 of the family proclamation, looking for who else can assist mothers and fathers in their responsibilities. Children may also help their parents fulfill their responsibilities.

Every family has its own difficulties and unique circumstances, but every family can live the teachings of Jesus Christ and find happiness.

 **5.** In your scripture study journal, write what you appreciate about your mother, your father, or your guardian.

Read paragraphs 8–9 of the family proclamation, looking for what will happen if we do not fulfill our responsibilities in our families.

One principle these paragraphs teach is that **the Lord will hold us accountable if we do not fulfill our responsibilities in our families.** You may want to write this truth on your copy of the proclamation.

Ponder how you are fulfilling your responsibilities in your family. Remember to seek the Lord’s help as you work toward your goal to better live one of the teachings of Jesus Christ in your family.

 **6.** Write the following at the bottom of today’s assignments in your scripture study journal:

*I have studied “The Family: A Proclamation to the World” lesson and completed it on (date).*

*Additional questions, thoughts, and insights I would like to share with my teacher:*

---

# THE FAMILY

---

## A PROCLAMATION TO THE WORLD

---

### THE FIRST PRESIDENCY AND COUNCIL OF THE TWELVE APOSTLES OF THE CHURCH OF JESUS CHRIST OF LATTER-DAY SAINTS

**WE**, THE FIRST PRESIDENCY and the Council of the Twelve Apostles of The Church of Jesus Christ of Latter-day Saints, solemnly proclaim that marriage between a man and a woman is ordained of God and that the family is central to the Creator's plan for the eternal destiny of His children.

**ALL HUMAN BEINGS**—male and female—are created in the image of God. Each is a beloved spirit son or daughter of heavenly parents, and, as such, each has a divine nature and destiny. Gender is an essential characteristic of individual premortal, mortal, and eternal identity and purpose.

**IN THE PREMORTAL REALM**, spirit sons and daughters knew and worshipped God as their Eternal Father and accepted His plan by which His children could obtain a physical body and gain earthly experience to progress toward perfection and ultimately realize their divine destiny as heirs of eternal life. The divine plan of happiness enables family relationships to be perpetuated beyond the grave. Sacred ordinances and covenants available in holy temples make it possible for individuals to return to the presence of God and for families to be united eternally.

**THE FIRST COMMANDMENT** that God gave to Adam and Eve pertained to their potential for parenthood as husband and wife. We declare that God's commandment for His children to multiply and replenish the earth remains in force. We further declare that God has commanded that the sacred powers of procreation are to be employed only between man and woman, lawfully wedded as husband and wife.

**WE DECLARE** the means by which mortal life is created to be divinely appointed. We affirm the sanctity of life and of its importance in God's eternal plan.

**HUSBAND AND WIFE** have a solemn responsibility to love and care for each other and for their children. "Children are an heritage of the Lord" (Psalm 127:3). Parents have a sacred duty to rear their children in love and righteousness,

to provide for their physical and spiritual needs, and to teach them to love and serve one another, observe the commandments of God, and be law-abiding citizens wherever they live. Husbands and wives—mothers and fathers—will be held accountable before God for the discharge of these obligations.

**THE FAMILY** is ordained of God. Marriage between man and woman is essential to His eternal plan. Children are entitled to birth within the bonds of matrimony, and to be reared by a father and a mother who honor marital vows with complete fidelity. Happiness in family life is most likely to be achieved when founded upon the teachings of the Lord Jesus Christ. Successful marriages and families are established and maintained on principles of faith, prayer, repentance, forgiveness, respect, love, compassion, work, and wholesome recreational activities. By divine design, fathers are to preside over their families in love and righteousness and are responsible to provide the necessities of life and protection for their families. Mothers are primarily responsible for the nurture of their children. In these sacred responsibilities, fathers and mothers are obligated to help one another as equal partners. Disability, death, or other circumstances may necessitate individual adaptation. Extended families should lend support when needed.

**WE WARN** that individuals who violate covenants of chastity, who abuse spouse or offspring, or who fail to fulfill family responsibilities will one day stand accountable before God. Further, we warn that the disintegration of the family will bring upon individuals, communities, and nations the calamities foretold by ancient and modern prophets.

**WE CALL UPON** responsible citizens and officers of government everywhere to promote those measures designed to maintain and strengthen the family as the fundamental unit of society.

*This proclamation was read by President Gordon B. Hinckley as part of his message at the General Relief Society Meeting held September 23, 1995, in Salt Lake City, Utah.*

---



SEMINARIES AND  
INSTITUTES OF RELIGION

---

THE CHURCH OF  
JESUS CHRIST  
OF LATTER-DAY SAINTS

ENGLISH

